



Designation: **E1509–12 (Reapproved 2017) E1509 – 22**

Standard Specification for Room Heaters, Pellet Fuel-Burning Type¹

This standard is issued under the fixed designation E1509; the number immediately following the designation indicates the year of original adoption or, in the case of revision, the year of last revision. A number in parentheses indicates the year of last reapproval. A superscript epsilon (ϵ) indicates an editorial change since the last revision or reapproval.

1. Scope

1.1 This specification covers performance requirements, test methods, and marking requirements for automatic feed, pellet fuel-burning room heaters that are intended to burn wood pellets or other suitable solid fuel. These room heaters shall be drafted by forced or natural means.

1.2 Exhaust venting systems and associated externally mounted draft inducers are not evaluated by this specification unless they are part of an engineered system provided as part of the room heater. Parts specifically evaluated and determined to be acceptable for use with pellet fuel-burning room heaters are required to be specified in the room heater manufacturer's instructions and are to be used in evaluating the room heater.

1.3 Pellet fuel-burning room heaters covered by this specification are intended for installation in accordance with the applicable requirements of NFPA 211 and in accordance with the applicable building and mechanical codes.

1.4 Pellet fuel-burning room heaters covered by this specification are acceptable for use in manufactured homes when installed in accordance with the Manufactured Home Construction and Safety Standards published by the Department of Housing and Urban Development (HUD). See 24 CFR Part 3280.

1.5 The terms "product" or "room heater," as used in this specification, refer to all pellet fuel-burning room heaters or any part thereof covered by the requirements of this specification, unless specifically noted otherwise.

1.6 No information provided in this specification is intended to prevent the use of other methods or devices, provided that sufficient technical data are submitted to the authority having jurisdiction to demonstrate that the proposed method or device is equivalent in quality, strength, fire endurance, effectiveness, durability, and safety to that prescribed in this specification.

1.7 The notes incorporated into this specification are not prescriptive requirements. They are given for clarification and informational purposes only.

1.8 The values stated in inch-pound units are to be regarded as standard. The values given in parentheses are mathematical conversions to SI units that are provided for information only and are not considered standard.

¹ This specification is under the jurisdiction of ASTM Committee E06 on Performance of Buildings and is the direct responsibility of Subcommittee E06.54 on Solid Fuel Burning Appliances.

Current edition approved Sept. 1, 2017; May 1, 2022. Published September 2017; June 2022. Originally approved in 1993. Last previous edition approved in 2012 as E1509 – 12; E1509 – 12 (2017). DOI: 10.1520/E1509-12R17; 10.1520/E1509-22.

1.9 The following safety hazards caveat pertains only to the test methods portion, Section 10, of this specification: *This standard does not purport to address all of the safety concerns, if any, associated with its use. It is the responsibility of the user of this standard to establish appropriate safety, health, and environmental practices and determine the applicability of regulatory limitations prior to use.*

1.10 *This international standard was developed in accordance with internationally recognized principles on standardization established in the Decision on Principles for the Development of International Standards, Guides and Recommendations issued by the World Trade Organization Technical Barriers to Trade (TBT) Committee.*

2. Referenced Documents

2.1 ASTM Standards:²

[C1057 Practice for Determination of Skin Contact Temperature from Heated Surfaces Using a Mathematical Model and Thermesthesiometer](#)

[D3211 Test Method for Relative Density of Black Smoke \(Ringelmann Method\) \(Withdrawn 1990\)³](#)

[E136 Test Method for Assessing Combustibility of Materials Using a Vertical Tube Furnace at 750°C](#)

[E631 Terminology of Building Constructions](#)

[E711 Test Method for Gross Calorific Value of Refuse-Derived Fuel by the Bomb Calorimeter \(Withdrawn 2011\)³](#)

[E871 Test Method for Moisture Analysis of Particulate Wood Fuels](#)

2.2 ANSI Standard:⁴

[ANSI B94.11 Twist Drills](#)

2.3 ASME Standard:⁵

[ASME B36.10M Welded and Seamless Wrought Steel Pipe](#)

2.4 U.S. Code of Federal Regulations—Housing and Urban Development:⁶

[24 CFR Part 3280 Manufactured Home Construction and Safety Standards](#)

2.5 Federal Communications Commission:⁶

[47 CFR Part 15, Subpart B FCC Regulations](#)

2.6 NFPA Standards:⁷

[NFPA 70 National Electrical Code](#)

[NFPA 211 Chimneys, Fireplaces, Vents and Solid-Fuel Burning Appliances](#)

2.7 UL Standards:⁸

[UL 103 Chimneys, Factory-Built, Residential Type and Building Heating Appliance](#)

[UL 181 Factory Made Air Ducts and Connectors](#)

[UL 641 Low-Temperature Venting Systems, Type L](#)

[UL 907 Fireplace Accessories](#)

[UL 969 Marking and Labeling Systems](#)

[UL 1482 Room Heaters, Solid Fuel Type](#)

2.8 ULC Standards:⁹

[ULC S609 Low Temperature Vents, Type L](#)

[ULC S629M 650°C Factory-Built Chimneys](#)

2.9 ICES Standard:¹⁰

[ICES-003 Digital Apparatus](#)

2.10 PFI Standard:¹¹

[PFI Standard Specification for Residential/Commercial Densified Fuel, June 1, 2011](#)

3. Terminology

3.1 *Definitions*—Terms used in this test method are defined in Terminology [E631](#).

3.2 *Definitions of Terms Specific to This Standard:*

² For referenced ASTM standards, visit the ASTM website, www.astm.org, or contact ASTM Customer Service at service@astm.org. For *Annual Book of ASTM Standards* volume information, refer to the standard's Document Summary page on the ASTM website.

³ The last approved version of this historical standard is referenced on www.astm.org.

⁴ Available from American National Standards Institute (ANSI), 25 W. 43rd St., 4th Floor, New York, NY 10036, <http://www.ansi.org>.

⁵ Available from American Society of Mechanical Engineers (ASME), ASME International Headquarters, Two Park Ave., New York, NY 10016-5990, <http://www.asme.org>.

⁶ Available from DLA Document Services, Building 4/D, 700 Robbins Ave., Philadelphia, PA 19111-5094, <http://quicksearch.dla.mil>.

⁷ Available from National Fire Protection Association (NFPA), 1 Batterymarch Park, Quincy, MA 02169-7471, <http://www.nfpa.org>.

⁸ Available from Underwriters Laboratories (UL), 333 Pfingsten Rd., Northbrook, IL 60062, <http://www.ul.com>.

⁹ Available from Underwriters Laboratories of Canada, 7 Underwriters Road, Toronto, ON Canada M1R 3B4, <http://www.ul.com/canada>.

¹⁰ Available from Industry Canada, C.D. Howe Building, 235 Queen Street, Ottawa, Ontario K1A 0H5, Canada, <http://www.ic.gc.ca/>.

¹¹ Available from Pellet Fuels Institute (PFI), 2150 N 107th St., Suite 205, Seattle, WA 98133, <http://pelletheat.org>.

3.2.1 *chimney*—one or more passageways, vertical or nearly so, for conveying flue gases to the outside atmosphere to which the appliance exhaust is capable of being connected.

3.2.2 *combustible material*—material made of or surfaced with wood, compressed paper, plant fibers, plastics, or other material that will ignite and burn, whether flameproofed or not, or whether plastered or unplastered.

3.2.3 *combustion air control*—a valve or plate or motor speed control, operated manually or automatically, that regulates the draft or flow of flue gases or inlet combustion air.

3.2.4 *connector pipe*—a flue pipe that is part of the exhaust venting system that ducts combustion products from the room heater to a chimney.

3.2.5 *exhaust venting system*—a flue pipe, either horizontal, vertical, or a combination of horizontal and vertical, that ducts combustion products from the room heater to the outside.

3.2.5.1 *Discussion*—

An exhaust venting system consists of a listed vent system, or connector pipe and a listed factory-built chimney, or a masonry chimney, or an engineered vent system provided as part of the pellet fuel-burning room heater.

3.2.6 *floor protector (stove mat)*—the noncombustible material applied to the combustible floor area located beneath the product and extending beyond the front and sides and to the rear of the product. The area is to be of the dimensions specified in the installation instructions.

3.2.7 *grate*—a frame for supporting the fuel within a room heater.

3.2.7.1 *Discussion*—

The grate in a pellet fuel-burning room heater is also referred to as a burn pot or fire pot.

3.2.8 *hearth*—the floor area within the fire chamber of a room heater.

3.2.9 *hopper*—an on-unit fuel reservoir that is gravity feeding through a bottom outlet to a controllable pellet fuel feed assembly.

3.2.10 *listed*—equipment or materials included in a list, published by an organization acceptable to the authority having jurisdiction and concerned with product evaluation, that maintains periodic inspection of the production of listed equipment or materials and whose listing states either that the equipment or material meets the appropriate standards or has been tested and found to be suitable for use in a specified manner.

3.2.11 *noncombustible material*—a material that, in the form in which it is used and under the conditions anticipated, will not ignite, burn, support combustion, or release flammable vapors when subjected to fire or heat. Materials reported as passing the test, when tested in accordance with Test Method E136, shall be considered noncombustible materials.

3.2.12 *pellet fuel*—a solid processed biomass fuel of specified size and composition capable of being fed to the room heater combustion system at a controlled rate.

3.2.13 *room heater, pellet fuel type*—a closed combustion, exhaust venting system connected, pellet fuel-burning room heater incorporating a fuel feed control mechanism.

4. Materials

4.1 The materials used shall be free of defects that will affect the performance and maintainability of individual components of the overall assembly.

4.2 A room heater and an exhaust venting system, if provided, shall be made of noncombustible corrosion-resistant materials. Metals shall not be used in combinations that have the potential to cause galvanic action at any location within the assembly.

4.3 The minimum metal thickness of room heater nondecorative parts, including any coatings, shall comply with the requirements given in **Table 1**.

4.4 Aluminum alloys containing more than 1 % magnesium shall not be used if the reflectivity of the material is employed to reduce fire risk.

4.5 The fire chamber and other parts of the room heater that are in contact with flue gases and are visible after installation shall be of material having the durability and resistance to fire and heat equivalent to fireclay tile, Series 300 or 400 stainless steel, aluminum-coated steel, cast iron, or ~~0.042-in. (1.07-mm)~~ 0.042 in. (1.07 mm) thick unprotected or painted steel.

NOTE 1—Cast iron and unprotected and painted sheet steel complying with the requirements of Footnotes *K* and *L* of **Table 2** comply with the requirements of **4.5**.

4.6 If required, chimney connectors shall be of materials and thicknesses complying with the requirements of NFPA 211 and applicable building and mechanical codes.

4.7 Thermal insulation material shall be of metal or mineral base. Asbestos materials shall not be used.

4.8 Thermal insulation shall comply with the following conditions when the room heater is tested in accordance with the following requirements:

4.8.1 The products resulting from the combustion or volatilization of any combustible binder shall be discharged to the exhaust venting system.

4.8.2 Insulating material shall remain in the intended position.

4.8.3 The insulation shall not show evidence of softening, melting, or deterioration in a manner that will inhibit its function or create a hazard.

4.9 Thermal insulation, other than firebox refractory materials, shall be protected from contact with combustion products.

4.10 Thermal insulation that is not self-supporting shall be applied to solid surfaces so that the insulation does not sag in any way that will interfere with the function of the insulation. An adhesive or cement used to attach such material shall retain its adhesive qualities at any temperature the adhesive attains when tested in accordance with these requirements and at 0 °F (−17.8 °C).

4.11 A water-absorbing insulating material shall be protected from wetting by condensation or rain when installed as intended.

4.12 Friable materials shall not be used in air handling compartments unless contained suitably.

5. Construction Requirements

5.1 General:

TABLE 1 Minimum Metal Thickness

	in.	mm
Aluminum-coated steel Type T1-40 (Regular, 0.40 oz/ft ² (0.12 kg/m ²))	0.018	0.46
Aluminum alloys	0.016	0.41
Cast iron	0.125	3.17
Galvanized steel G60 coating class	0.018	0.45
Porcelain-enameled steel	0.032	0.81
Stainless steel	0.012	0.30
Steel, uncoated or painted	0.042	1.07

TABLE 2 Maximum Temperature Increases

Materials and Components	Column 1		Column 2	
	°C	°F	°C	°F
(A) Motor^{A, B, C}				
(1) Class A insulation systems on coil windings of alternating-current motors 7 in. (178 mm) or less in diameter (not including universal motors):				
(a) In open motors:	75	135	115	207
Thermocouple or resistance method				
(b) In totally enclosed motors:	80	144	115	207
Thermocouple or resistance method				
(2) Class A insulation systems on coil windings of alternating-current motors more than 7 in. (178 mm) in diameter and of direct-current and universal motors:				
(a) In open motors:	65	117	115	207
Thermocouple method	75	135	115	207
Resistance method				
(b) In totally enclosed motors:	70	126	115	207
Thermocouple method	80	144	115	207
Resistance method				
(3) Class B insulation systems on coil windings of alternating-current motors 7 in. (178 mm) or less in diameter (not including universal motors):				
(a) In open motors:	95	171	140	252
Thermocouple or resistance method				
(b) In totally enclosed motors:	100	180	140	252
Thermocouple or resistance method				
(4) Class B insulation systems on coil windings of alternating-current motors more than 7 in. (178 mm) in diameter and of direct-current and universal motors:				
(a) In open motors:	85	153	140	252
Thermocouple method	95	171	140	252
Resistance method				
(b) In totally enclosed motors:	90	162	140	252
Thermocouple method	100	180	140	252
Resistance method				
(B) Components^C				
(1) Capacitors:				
(a) Electrolyte types	40	72	(not specified)	
(b) Other types ^D	65	117		
(2) Relay, solenoid, and other coils with:				
(a) Class 105 insulation systems:	65	117	115	207
Thermocouple method	85	153	115	207
Resistance method				
(b) Class 130 insulation systems:	85	153	140	252
Thermocouple method	105	189	140	252
Resistance method				
(3) Transformer enclosure: ^B				
(a) Class 2 transformers	60	108	85	153
(b) Power and ignition transformers	65	117	90	162
(C) Insulated Conductors^{C, E, F}				
(1) Appliance wiring material:				
75 °C rating	50	90	65	117
80 °C rating	55	99	70	126
90 °C rating	65	117	80	144
105 °C rating	80	144	95	171
200 °C rating	175	315	200	360
250 °C rating	225	405	250	450
(2) Flexible cord—Types SO, ST, SJO, SJT, HSJ, and HSJO:				
60 °C rating	35	63	60	108
75 °C rating	50	90	65	117
90 °C rating	65	117	80	144
105 °C rating	80	144	95	171
(3) Other types of insulated wires:		see footnote ^E		
(D) Electrical Insulation—General^{C, F}				
(1) Class C electrical insulation material			not specified	
(2) Class (180) electrical insulation material			as determined by test	
(3) Fiber used as electrical insulation or cord bushings	65	117	90	162
(4) Phenolic composition used as electrical insulation or as parts where malfunction will result in a risk of fire or electric shock	125	225	150	270
(5) Thermoplastic material		25 °C or 77 °F less than its temperature rating		
(6) Varnished cloth insulation	60	108	85	153
(E) Metals^G				
(1) Aluminum alloys:				
(a) 1100 (2S)	183	330	239	430
(b) 3003 (3S)	239	430	294	530
(c) 2014, 2017, 2024, and 5052 ^H	294	530	350	630

TABLE 2 *Continued*

Materials and Components	Column 1		Column 2	
	°C	°F	°C	°F
(2) Aluminum-coated steel, heat-resistant type ^f	572	1030	708	1275
(3) Carbon steel—coated with Type A19 ceramic	572	1030	628	1130
(4) Galvanized steel ^f	267	480	350	630
(5) Low-carbon steel, cast iron ^{K, L}	461	830	517	930
(6) Stainless steel:				
(a) Types 302, 303, 304, 321, and 347	686	1235	767	1380
(b) Type 316	667	1200	748	1345
(c) Type 309S	867	1560	950	1705
(d) Types 310, 310B	894	1610	975	1755
(e) Type 430	728	1310	808	1455
(f) Type 446	961	1730	1042	1875
(F) General				
(1) Operating knobs, handles, and levers: ^{M, N}				
(a) Metallic	50	122	not specified	
(b) Glass	78	172		
(c) Plastic ^O	85	185		
(d) Wood	150	302		
(e) Other Materials	^P			
(2) Internal hopper surface	82	180	150	302

^A The motor diameter is to be measured in the plane of the laminations of the circle circumscribing the stator frame, excluding lugs, boxes, and the like, used solely for motor cooling, mounting, assembly, or connection.

^B Ordinarily, coil or winding temperatures are to be measured by thermocouples unless the coil is inaccessible for mounting of these devices (for example, a coil immersed in sealing compound) or unless the coil wrap includes thermal insulation or more than two layers, $\frac{1}{32}$ in. (0.8 mm) maximum, of cotton, paper, rayon, or the like. For a thermocouple-measured temperature of a coil of an alternating-current motor, having a diameter of 7 in. (178 mm) or less, the thermocouple is to be mounted on the integrally applied insulation on the conductor. At a point on the surface of a coil where the temperature is affected by an external source of heat, the temperature increase measured by a thermocouple shall be allowed to exceed the indicated maximum by the amount noted as follows, provided that the temperature increase of the coil, as measured by the resistance method, is not more than that specified in the table.

(1) 5 °C (9 °F) for Class A insulation on coil windings of alternating-current motors having a diameter of 7 in. (178 mm) or less, open type.

(2) 10 °C (18 °F) for Class B insulation on coil windings of alternating-current motors having a diameter of 7 in. (178 mm) or less, open type.

(3) 15 °C (27 °F) for Class A insulation on coil windings of alternating-current motors having a diameter of more than 7 in. (178 mm), open type.

(4) 20 °C (36 °F) for Class B insulation on coil windings of alternating-current motors having a diameter of more than 7 in. (178 mm), open type.

^C Maximum temperature increases are based on an ambient temperature of 25 °C or 77 °F.

^D A capacitor that operates at a temperature above a 65 °C (117 °F) increase shall be judged on the basis of its marked temperature rating.

^E For standard insulated conductors other than those mentioned, reference shall be made to the National Electrical Code; the maximum allowable temperature rise in any case is 25 °C or 77 °F less than the temperature rating of the insulation in question where Column 1 temperature increases are specified, and the maximum allowable temperature increase where Column 2 increases are specified is to be based on the heat-resistant properties of the insulation. Column 2 temperature increases are 15 °C (27 °F) above Column 1.

^F The limitations on phenolic composition and on rubber and thermoplastic insulation do not apply to compounds that have been investigated and found to have special heat-resistant properties.

^G The specified maximum temperature increases apply to parts whose malfunction has the potential to cause the product to be unsuitable for use.

^H These and other alloys containing more than 1 % magnesium shall not be used when the reflectivity of the material is employed to reduce the risk of fire.

^I When the reflectivity of aluminum-coated steel is used to reduce fire risk, the maximum allowable temperature increase is 830 °F (461 °C).

^J The specified maximum temperature increases shall apply when the galvanizing is required as a protective coating or the reflectivity of the surface is used to reduce fire risk.

^K The specified maximum temperature increases shall not apply to parts of No. 8 gage (3.86 mm) or heavier steel and ~~$\frac{3}{16}$ in. (4.8 mm)~~ in. (4.8 mm) thick or heavier cast iron used for the hearth and to other parts of No. 12 gage (2.36 mm) or heavier steel, and ~~$\frac{1}{8}$ in. (3.2 mm)~~ in. (3.2 mm) thick or heavier cast iron when: (1) the part is not the only enclosure, and (2) malfunction of the part will not expose adjacent combustible construction to the fire in the fire chamber.

^L The specified maximum temperature increase shall not apply to parts of $\frac{1}{4}$ in. (6.4 mm) or heavier steel and ~~$\frac{5}{16}$ in. (7.9 mm)~~ in. (7.9 mm) thick or heavier cast iron.

^M Handle temperatures are maximum temperatures, based on an ambient temperature of 70 °F or 21 °C.

^N The limitations on operating knobs, handles, and levers does not apply to knobs used for adjusting combustion air inlets or damper handles that do not require adjustment during operation.

^O Includes plastic with a metal plating not more than ~~0.005 in. (0.13 mm)~~ 0.005 in. (0.13 mm) thick; and metal with a plastic or vinyl covering not less than ~~0.005 in. 0.005 in.~~ thick.

^P Other handle materials shall have a limiting temperature determined by the calculation method specified in Practice C1057 such that the temperature limit does not result in a tissue temperature of greater than 50 °C at a tissue depth of 0.008 cm with a contact time of 5 seconds.

5.1.1 A room heater and related parts shall be constructed and assembled so as to have the strength, rigidity, and durability to withstand damage during tests in accordance with the following requirements and during handling and installation.

5.1.2 A joint in a metal surface of a fire chamber or flue gas passageway in a room heater shall be secured mechanically by being welded, lock-seamed, riveted, or bolted. A joint shall be fastened together securely such that it does not rely solely on a cement compound for tightness.

5.1.3 Each part or assembly shall be constructed for attachment of one to the other without requiring alteration, cutting, threading, drilling, welding, or similar tasks by the installer.

5.1.3.1 *Exception*—If an assembly or component part is intended to be cut to length or to be fitted by the installer, means shall

be provided for joining any altered part to a companion part or assembly. All fasteners required to complete the assembly shall be provided with the product by the manufacturer. Drilling is acceptable if the drilling operation does not weaken the assembly or drill into the fire chamber, and the size of the required drill bit is specified and instructions describe the locations to be drilled clearly, such as by the use of templates, drawings, descriptions, or the like.

5.1.4 Insulating materials shall be an integral part of the assembly if required to protect combustible parts of the building when the room heater is installed in accordance with the manufacturer's instructions.

5.1.4.1 *Exception*—If fire chamber materials are packaged and shipped with the heater, the installation instructions shall provide for a description of the method of placement of this material, and the heater shall be marked with an adhesive-backed warning marking indicating that the material is to be installed before firing.

5.1.5 Two or more parts or subassemblies that are required or intended to bear a definite relationship to each other shall be arranged and constructed so as to permit them to be incorporated into the complete assembly without need for alteration or alignment and only in the correct relationship with each other, or they shall be assembled and shipped from the factory as a single component.

5.1.6 Parts of a room heater, such as support legs, radiation shields, and the like, that are necessary to limit temperatures on adjacent construction shall be factory-attached, or they shall comply with all of the following requirements:

5.1.6.1 The parts shall be shipped with the room heater, or they shall be marked with the name or trademark of the manufacturer or private labeler, with a catalog number or equivalent designation, and with the type of equipment with which they are intended to be used. The associated heater shall be marked to indicate the catalog number, or equivalent designation of such a part, and the name of the manufacturer or private labeler of that part.

5.1.6.2 Assembly of the parts shall comply with the requirements given in 5.1.3.

5.1.6.3 The installation instructions shall define and illustrate the intended assembly of the parts.

5.1.7 The room heater shall have no edges, corners, or projections presenting risk of a cut or puncture-type injury to persons.

5.2 *Flue Collar*—A flue collar shall provide for ready attachment of the specified exhaust venting system and fastening of the exhaust venting system by at least two screws or other equivalent mechanical methods.

<https://standards.iteh.ai/catalog/standards/sist/675386bf-884b-4dd0-971b-d9f9367ad22b/astm-e1509-22>
5.3 *Radiation Shield and Baffle*—If provided, a radiation shield or a baffle shall be constructed, formed, and supported to provide the intended positioning and to prevent distortion or sagging.

5.4 *Separable Handle*:

5.4.1 If provided, a separable handle shall not remain in position when the user's hand is withdrawn following use.

5.4.2 Storage means shall be provided on the device for separable handles so that when the handle is stored as intended, the temperatures on the separable handle shall not exceed the specified temperature limits.

5.5 *Combustion Air Duct System*:

5.5.1 The combustion air duct system (if applicable) shall be made of sheet metal not less than ~~0.016 in. (0.41 mm)~~ 0.016 in. (0.41 mm) thick.

5.5.1.1 *Exception*—Thinner materials are permitted when conforming to UL 181 for Class 0 and Class 1 air ducts and when they have been investigated for the intended application.

5.5.2 The air inlet shall permit zero clearance to combustible construction.

5.5.3 The air inlet shall prevent material from dropping into the inlet or into the area beneath the dwelling, and it shall also prevent rodents from entering from outside.

NOTE 2—A wire mesh having openings not larger than ~~0.250~~0.25 in. by 0.25 in. (~~6.4~~6.4 mm by 6.4 mm) is acceptable for this purpose.

5.6 Exhaust Venting System:

5.6.1 *Products Employing Low-Temperature Type L Vent*—When the room heater is intended to be installed with a Type L vent system, the vent shall be listed to the requirements of UL 641 or ULC S609 and determined suitable for use with solid fuel pellet-burning appliances. The termination shall be designed such that exhaust gases and sparks are not directed toward combustible surfaces and such that the ingress of rain is prevented.

5.6.2 *Products Employing a Chimney*—When a room heater is intended to exhaust to a chimney, the connector pipe from the room heater to the wall thimble or ceiling adapter shall meet the requirements specified in NFPA 211 or the applicable building and mechanical codes. If factory-built, the chimney specified shall be listed to the requirements of UL 103 or ULC S629M or, if masonry, shall meet the construction requirements of the applicable building and mechanical codes. The flue size and height requirements shall not be less than those specified by the manufacturer of the room heater.

5.6.3 Products Employing an Externally Mounted Draft Inducer:

5.6.3.1 When a room heater is intended to be installed such that a draft inducer terminates on an exterior wall, the termination shall be designed such that exhaust gases and sparks are not directed toward combustible surfaces.

5.6.3.2 When a room heater is intended to be installed with an externally mounted draft inducer, the exhaust venting system from the room heater to the draft inducer shall be listed to the requirements of UL 641 or ULC S609 and determined to be suitable for use with solid fuel pellet-burning appliances using an externally mounted draft inducer.

5.6.3.3 *Exception*—If a listed vent is not used, the flue connection from the room heater to the draft inducer shall be acceptable if the exhaust venting system is constructed such that the exterior surfaces of the vent do not exceed the temperature limits specified in 7.1.1 and 7.2.1 and the flue gas conduit has corrosion resistance and durability equivalent to Series 300 or 400 stainless steel, unless failure of the conduit will not render the unit unsafe, such as in the case of products of combustion entering the living space.

5.6.4 Externally Mounted Draft Inducers:

5.6.4.1 If the manufacturer's specified periodic maintenance includes removal of the fan unit from the assembly for cleaning, provision for disconnecting power to the motor shall be made within the enclosure.

5.6.4.2 The draft inducer housing shall include provision for connecting an additional outdoor vent system.

5.7 Fuel Hopper:

5.7.1 The fuel hopper assembly shall be constructed such that fuel or fuel residue cannot enter areas within the appliance enclosure or come into contact with exterior surfaces of the fire chamber. Fuel hopper sections shall be fastened together securely such that they do not rely solely on a sealing compound or tape for tightness.

5.7.2 A fuel feed mechanism that presents an entrapment or other mechanical hazard and which can be contacted by the accessibility probe as shown in Fig. 1 shall have a fuel hopper lid or door with a direct interlock to the fuel feed motor so that the mechanism is disabled when the hopper is opened. Guards or shields that prevent access to mechanical hazards shall be permanent or require the use of tools for removal. When removable guards or shields are used a cautionary warning shall be included inside the hopper cover with the following wording or equivalent:

“CAUTION: Disconnect electrical power before removing guard(s). Reinstall guard(s) after servicing. Never operate this appliance without the guard(s) in place.”

5.7.3 If provided, the hopper lid/door seal gasketing shall be attached to the lid/door, or the design and construction shall be such that damage to the gasketing during normal operation and filling of the hopper is prevented.

5.8 *Special Tools*—Where special tools are required to remove carbon and slag buildup from the grate (burn pot), they shall be supplied with the room heater.

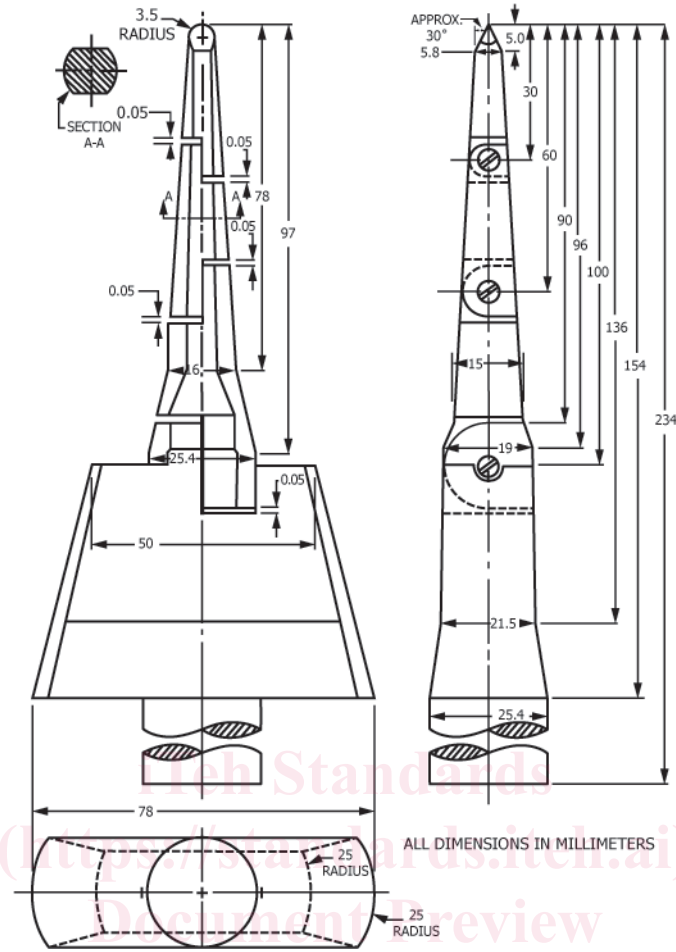

FIG. 1 Accessibility Probe

ASTM E1509-22

<https://standards.iteh.ai/catalog/standards/sist/675386bf-884b-4dd0-971b-d9f9367ad22b/astm-e1509-22>

5.9 *Gasket Materials*—When components require removal, for example, during periodic maintenance, such removal shall not render the gasket or seal incapable of forming a suitable seal when the components are reassembled with a gasket or seal replacement.

5.10 *Glazing Materials*—The glazing used in the room heater shall be either a glass-ceramic or tempered glass with a minimum thickness of 0.197 in. (5 mm). The glazing material shall be able to resist thermal shock. Tempered glass glazing materials shall be able to resist impact.

5.11 *Blower and Pellet Fuel Feed Assemblies*—The following components and features shall meet the construction requirements specified in UL 1482:

- 5.11.1 Enclosure,
- 5.11.2 Mounting of electrical components,
- 5.11.3 Field-installed blower assemblies,
- 5.11.4 Field supply connections,
- 5.11.5 Grounding,
- 5.11.6 Internal wiring,

5.11.7 Separation of circuits,

5.11.8 Bonding of grounding,

5.11.9 Capacitors,

5.11.10 Insulating material,

5.11.11 Motors and motor overcurrent (overload) protection,

5.11.12 Switches and controllers,

5.11.13 Transformers, and

5.11.14 Spacings.

5.12 *Convection Air Blower Filter*—When a filter is provided for the convection air blower, it shall be accessible after installation.

iTeh Standards
(<https://standards.iteh.ai>)
Document Preview

[ASTM E1509-22](#)

<https://standards.iteh.ai/catalog/standards/sist/675386bf-884b-4dd0-971b-d9f9367ad22b/astm-e1509-22>

5.13 *Room Heaters for Use in Manufactured Homes:*

5.13.1 Means shall be provided for securing the room heater to the floor of the manufactured home.

5.13.2 The room heater shall not draw combustion air from the interior spaces of manufactured housing.

5.13.3 A room heater and its exhaust venting system shall not void the firestopping required between spaces of a manufactured home when the room heater, its exhaust venting system, and the combustion air inlet are installed in accordance with the manufacturer's instructions.

5.14 *Components:*

5.14.1 A mechanical component of a product covered by this specification shall comply with the requirements for that component as specified in the standards listed in Section 2.

5.14.2 *Exception*—A mechanical component need not comply with a specific requirement that (1) involves a feature or characteristic not necessary in the application of the component in the product covered by this specification or (2) is superseded by a requirement in this specification.

5.14.3 A mechanical component shall be used in accordance with its recognized rating established for the intended conditions of use.

6. Electrical Requirements

6.1 *Convection and Combustion Blower Assemblies*—Blower assemblies shall comply with the following blower assembly performance requirements specified in UL 1482:

6.1.1 Test voltages,

6.1.2 Temperature measurements,

6.1.3 Input test,

6.1.4 Dielectric voltage—withstand test,

6.1.5 Leakage current test,

6.1.6 Stalled motor test,

6.1.7 Strain relief test,

6.1.8 Short-circuit test, and

6.1.9 Knockout test.

6.2 *Pellet Fuel Feed Assembly*—A motor-driven pellet fuel feed assembly shall comply with all of the above-specified performance requirements for blower assemblies.

6.3 *Electronic Controls or Circuit Boards*—All components used in the control unit shall bear a recognized component marking or the complete assembly shall bear the manufacturer's name, an identification mark, and mark of a laboratory that maintains periodic inspection of the production of equipment and materials and states that the equipment or material meets appropriate standards or has been tested and found suitable for use in a specified manner.

NOTE 3—Electronic controls and circuits boards must also be evaluated for compliance with 47 CFR Part 15, Subpart B, for the United States and ICES-003 for Canada.

6.4 *Wiring*—Wiring methods shall comply with the requirements of NFPA 70 and UL 1482.

6.5 *Components*:

6.5.1 An electrical or electronic component of a product covered by this specification shall comply with the specified requirements for that component.

6.5.2 *Exception*—An electrical or electronic component need not comply with a specific requirement that (1) involves a feature or characteristic not necessary in the application of the component in the product covered by this specification or (2) is superseded by a requirement in this specification.

6.5.3 An electrical or electronic component shall be used in accordance with its recognized rating established for the intended conditions of use.

6.6 *Electrical Component Temperature Increase*:

6.6.1 Temperature increases shall be measured on the electrical components and enclosures of the blower assemblies and pellet fuel feed assembly when tested in accordance with 10.1.3 and shall not be greater than those specified for the specific component in Column 1 of Table 2.

6.6.2 Temperature increases shall be measured on the electrical components and enclosures of the blower assemblies and pellet fuel feed assembly when tested in accordance with 10.1.4 and shall not be greater than those specified for the specific component in Column 2 of Table 2.

7. Performance Requirements

7.1 *Performance During Maximum Burning Conditions*:

7.1.1 *Maximum Temperature Increase*—Maximum temperature increases above ambient temperature shall not exceed the following limits when tested in accordance with 10.1.3:

7.1.1.1 Temperature of 117 °F (65 °C) on exposed surfaces of the test structure;

7.1.1.2 Temperature of 90 °F (50 °C) on unexposed surfaces of the test structure, such as beneath the heater or floor protector or behind a wall-mounted shield; and

7.1.1.3 Temperature of 90 °F (50 °C) on surfaces of exhaust venting system parts at points of zero clearance to the test structure and air inlet parts at points of zero clearance to the test structure.

7.1.1.4 The maximum values specified in Column 1 of Table 2 for the material used in any part of the room heater and exhaust venting system, if provided as part of the heater.

7.1.2 *Maximum Flue Gas Temperature for Listed Venting Systems*:

7.1.2.1 The maximum temperature of the flue gases entering the chimney shall not exceed 930 °F (517 °C) above ambient temperature if tested for use with connector pipe and a chimney listed to the requirements of UL 103 or ULC S629M.

7.1.2.2 The maximum temperature of the flue gases entering the exhaust venting system shall not exceed 500 °F (260 °C) above ambient temperature if tested for use with a venting system listed to the requirements of UL 641 or ULC S609 and determined suitable for use with solid fuel pellet-burning appliances.

7.1.3 *Maximum Room Temperature*—The room temperature shall not increase more than 20 °F (11 °C) above the value recorded at the beginning of the test.

7.2 *Performance with a Failed Component*: