



Designation: **F1977–04 (Reapproved 2017) F1977 – 22**

## Standard Test Method for Determining Initial, Fractional, Filtration Efficiency of a Vacuum Cleaner System<sup>1</sup>

This standard is issued under the fixed designation F1977; the number immediately following the designation indicates the year of original adoption or, in the case of revision, the year of last revision. A number in parentheses indicates the year of last reapproval. A superscript epsilon ( $\epsilon$ ) indicates an editorial change since the last revision or reapproval.

### 1. Scope

1.1 This test method may be used to determine the initial, fractional, filtration efficiency of household and commercial canister (tank-type), stick, hand-held, upright, and utility vacuum cleaner systems.

1.1.1 Water-filtration vacuum cleaners which do not utilize a replaceable dry media filter located between the water-based filter and cleaning air exhaust are not included in this test method. It has been determined that the exhaust of these vacuum cleaners is not compatible with the specified discrete particle counter (DPC) procedure.

1.2 The initial, fractional, filtration efficiencies of the entire vacuum cleaner system, at six discrete particle sizes (0.3, 0.5, 0.7, 1.0, 2.0, and  $>3 \mu\text{m}$ ), is derived by counting upstream challenge particles and the constituent of downstream particles while the vacuum cleaner system is being operated in a stationary test condition.

1.3 The vacuum cleaner system is tested either at the nozzle with the normal airflow rate produced by restricting the inlet to the nozzle adapter with the floor nozzle, the end of the hose (handle), or at the vacuum cleaner inlet (for handheld products) at  $\frac{1}{4}$ -in. orifice; the normal airflow rate.

1.4 The vacuum cleaner system is tested with a new filter(s) installed, and with no preliminary dust loading. The fractional efficiencies determined by this test method shall be considered initial system filtration efficiencies. ~~The filters are not changed between test runs on the same cleaner.~~

1.5 Neutralized potassium chloride (KCl) is used as the challenge media in this test method.

1.6 One or two particle counters may be used to satisfy the requirements of this test method. If using one counter, flow control is required to switch between sampling the upstream and downstream air sampling probes.

1.7 To efficiently utilize this test method, automated test equipment and computer ~~automation~~ data acquisition is recommended.

1.8 Different sampling parameters, flow rates, and so forth, for the specific applications of the equipment and test procedure may provide equivalent results. It is beyond the scope of this test method to define those various possibilities.

1.9 This test method is limited to the test apparatus, or its equivalent, as described in this document.

<sup>1</sup> This test method is under the jurisdiction of ASTM Committee F11 on Vacuum Cleaners and is the direct responsibility of Subcommittee F11.23 on Filtration. Current edition approved March 1, 2017; Jan. 1, 2022. Published March 2017; June 2022. Originally approved in 1999. Last previous edition approved in 2010 as F1977 – 04 (2010); (2017). DOI: [10.1520/F1977-04R17](https://doi.org/10.1520/F1977-04R17); [10.1520/F1977-22](https://doi.org/10.1520/F1977-22).

1.10 This test method is not intended or designed to provide any measure of the health effects or medical aspects of vacuum cleaning.

1.11 This test method is not intended or designed to determine the integrity of HEPA filtration assemblies used in vacuum cleaner systems employed in nuclear and defense facilities.

1.12 The inch-pound system of units is used in this test method, except for the common usage of the micrometer,  $\mu\text{m}$ , for the description of particle size which is a SI unit.

1.13 *This standard does not purport to address all of the safety concerns, if any, associated with its use. It is the responsibility of the user of this standard to establish appropriate safety, health, and environmental practices and determine the applicability of regulatory limitations prior to use.*

1.14 *This international standard was developed in accordance with internationally recognized principles on standardization established in the Decision on Principles for the Development of International Standards, Guides and Recommendations issued by the World Trade Organization Technical Barriers to Trade (TBT) Committee.*

## 2. Referenced Documents

### 2.1 ASTM Standards:<sup>2</sup>

D1193 Specification for Reagent Water

D1356 Terminology Relating to Sampling and Analysis of Atmospheres

D3154 Test Method for Average Velocity in a Duct (Pitot Tube Method)

F50 Practice for Continuous Sizing and Counting of Airborne Particles in Dust-Controlled Areas and Clean Rooms Using Instruments Capable of Detecting Single Sub-Micrometre and Larger Particles

F395 Terminology Relating to Vacuum Cleaners

F558 Test Method for Measuring Air Performance Characteristics of Vacuum Cleaners

### 2.2 Other Documents:

~~HES Recommended Practice CC021.1 Testing HEPA and ULPA Filter Media~~<sup>3</sup>

~~HES Recommended Practice CC001.3 IEST-RP-CC001 Recommended Practice for HEPA and ULPA Filters~~<sup>3</sup>

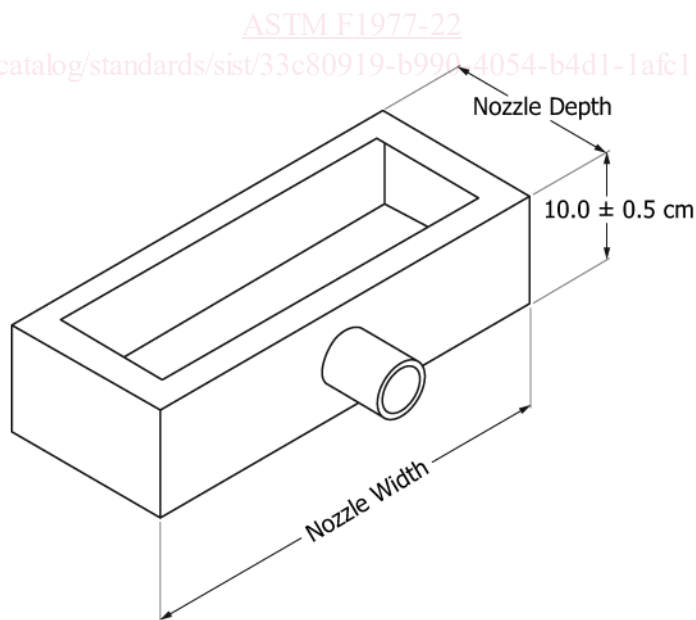

FIG. 1 Nozzle Adapter

<sup>2</sup> For referenced ASTM standards, visit the ASTM website, [www.astm.org](http://www.astm.org), or contact ASTM Customer Service at [service@astm.org](mailto:service@astm.org). For *Annual Book of ASTM Standards* volume information, refer to the standard's Document Summary page on the ASTM website.

<sup>3</sup> Available from Institute of Environmental Sciences and Technology (IEST), Arlington Place One, 2340 S. Arlington Heights Rd., Suite 100, Arlington Heights, IL 60005-4516, <http://www.iest.org>.

ISO Guide 25 General Requirements for the Competence of Calibration and Testing Laboratories<sup>4</sup>  
 EN 1822:2017 High Efficiency Air Filters (HEPA and ULPA) Fans – Performance testing using standardized airways<sup>4</sup>  
 ISO 29463-1 High-efficiency filters and filter media for removing particles in air – Part 1: Classification, performance testing and marking<sup>4</sup>

### 3. Terminology

#### 3.1 Definitions of Terms Specific to This Standard:

3.1.1 *challenge, n*—aerosolized media introduced upstream of the test unit and used to determine the filtration characteristics of the test unit.

##### 3.1.1.1 Discussion—

Also known as test aerosol. The term “contaminant” shall not be used to describe the media or aerosol used to challenge the filtration system in this test method. The term “contaminant” is defined in Terminology **D1356** and does not meet the needs of this test method.

3.1.2 *chamber airflow, n*—the sum of all airflows measured at a point near the downstream probe.

3.1.3 *filter, n*—the entity consisting of the converted filter media and other items required to be employed in a vacuum cleaner for the purpose of arresting and collecting particulate matter from the dirt-laden air stream; sometimes referred to as a filter element, filter assembly, cartridge, or bag.

3.1.4 *normal airflow, n*—that airflow occurring at the system’s nozzle due to the produced by the vacuum cleaner when operating ¼-in. orifice restriction at the inlet to the nozzle adapter at maximum normal use settings.

3.1.5 *nozzle adaptor, n*—a small plenum chamber, fabricated to mount to the inlet nozzle of the test unit in a sealable manner and shown in Fig. 1, to be used for vacuum cleaners without above the floor cleaning capabilities.

##### 3.1.5.1 Discussion—

Construction specifications are discussed in the Apparatus section.

3.1.6 *particle count, n*—the numeric sum of particles per cubic foot over the specified sample time.

##### 3.1.6.1 Discussion—

Throughout this test method, the units of measure for this term, generally, do not accompany the term “particle count” and are assumed to be understood by the reader.

3.1.7 *primary motor(s), n*—the motor(s) which drive(s) the blower(s); fan(s), producing airflow through the vacuum cleaner.

3.1.8 *secondary motor(s), n*—the motor(s) in the vacuum cleaner system not employed for the generation of airflow.

3.1.9 *sheath air, n*—the air flowing over and around the test unit that is mounted in the test chamber.

3.1.10 *stabilization, n*—those conditions of operation which produce results having a total variation of less than 3 % and at least 1000 total count in all size ranges for challenge-challenge, and equal to or less than 15 counts per cubic foot in the 0.3-µm channel for the background count.

##### 3.1.10.1 Discussion—

Total variation is calculated as the maximum data point minus the minimum data point difference between the maximum particle count and the minimum particle count divided by the maximum data point times 100-particle count in percentage. The difference is determined within the same period of the test.

##### 3.1.10.2 Discussion—

The assurance of statistical control is not a simple matter and needs to be addressed. A process is in a state of statistical control if the variations between the observed test results vary in a predictable manner and show no unassignable trends, cyclical characteristics, abrupt changes, excess scatter, or other unpredictable variations.

3.1.11 *system filtration efficiency, n*—a numerical value based on the ratio of a discrete size, particle count emerging from the vacuum cleaner, relative to the upstream challenge, particle count of the same size.

<sup>4</sup> Available from International Organization for Standardization (ISO), 1, ch. de la Voie-Creuse, Case postale 56, CH-1211, Geneva 20, Switzerland, <http://www.iso.ch>.

3.1.12 *test chamber, n*—the enclosed space surrounding the vacuum cleaner being tested, used to maintain the controlled environmental conditions required during the test procedure.

3.1.13 *test run, trial, n*—the definitive procedure that produces a singular measured result.

3.1.13.1 *Discussion*—

A ~~test run~~ *trial* is the period of time during which one complete set of upstream or downstream air sample data, or both, is acquired.

3.2 *Definitions:*

3.2.1 *aerosol, n*—a suspension of solid or liquid particles in a gas.

3.2.2 *background particles, n*—extraneous particles in the air stream prior to the start of the test.

3.2.2.1 *Discussion*—

Under conditions required of this test method, extraneous particles will be found to pass through the test chamber (for example, particles penetrating the test chamber's HEPA filters or being abraded or released from the surfaces of tubing and test equipment). Operating under stabilized conditions, these particles shall be counted in the downstream flow and subsequently subtracted from the test data to determine the initial, fractional, filtration efficiency of the test unit (see **Note 3**).

3.2.3 *channel, n*—*in particle analyzers*, a group of particle sizes having a definitive range; the lower end of the range identifies the channel, for example, a range of particle sizes from 0.3 to 0.5  $\mu\text{m}$  is identified as the 0.3- $\mu\text{m}$  channel.

3.2.4 *coincidence error, n*—*in particle analyzers*, errors occurring at concentration levels near or above the design limits of the instrument being used because two or more particles are simultaneously being sensed.

3.2.5 *diffusion dryer, n*—*in aerosol technology*, a device containing desiccant, surrounding the aerosol flow path, that removes excess moisture by diffusion capture.

3.2.6 *diluter, n*—*in aerosol technology*, a device used to reduce the concentration of particles in an aerosol.

3.2.7 *downstream, adv*—signifies the position of any object or condition that is physically in or part of the airflow stream occurring after the referenced item.

3.2.8 *DPC, n*—an acronym for ~~discrete particle counter~~ Discrete Particle Counter.

3.2.8.1 *Discussion*—

The **HES**IEST Recommended Practice CC001.3 and Practice **F50** describe a discrete particle counter as an instrument that utilizes light-scattering or other suitable principle to count and size discrete particles in air, and that displays or records the results. The discrete particle counter is also known as a single-particle counter or simply as a particle counter and it determines geometric rather than aerodynamic particle size.

3.2.9 *fractional efficiency, n*—a numerical value based on the ratio of the number of emergent, downstream particles of a discrete size, relative to the number of incident, upstream particles of the same size.

3.2.9.1 *Discussion*—

In practice, a single particle size is reported, having an understood or assumed size range equal to the channel size. This value is also known as the differential size efficiency or particle size efficiency, or both.

3.2.10 *fractional efficiency curve, n*—the fractional efficiency plotted as a function of the particle size.

3.2.11 *HEPA, adj*—an acronym for high-efficiency particulate air.

3.2.11.1 *Discussion*—

Additional information pertaining to HEPA may be found in **I**ES-21.1 (99.97% at 0.3  $\mu\text{m}$  in salt as modified) or **E**N-1822 (H12 or better at 0.3  $\mu\text{m}$  rather than most penetrating particle size); IEST-RP-CC001 or ISO 29463-1.

3.2.12 *laminar, adj*—in pneumatics, nonturbulent, laminar flow through a pipe is considered laminar when the Reynolds number is less than approximately 2000 and turbulent for a Reynolds number greater than approximately 4000.

3.2.12.1 *Discussion*—

Laminar flow in a pipe is characterized by a smooth symmetrical pattern of streamlines. The Reynolds number is a ~~non-dimensional~~ non-dimensional unit of measure proportional to the ratio of the inertial force of the gas to the frictional forces acting on each element of the fluid.<sup>5,6</sup>

3.2.13 *neutralizer, n*—in aerosol technology, a device used to minimize losses and coagulation caused by electrostatic charges, and to counteract high charge levels in aerosols generated by nebulization, combustion, or dispersion by neutralizing the particle charge level to the Boltzmann distribution level.

3.2.13.1 *Discussion*—

Neutralizers generally use radioactive Krypton gas, Kr-85, sealed in a stainless steel tube shielded by an outer metal housing.

3.2.14 *particle, n*—a small, discrete object.

3.2.15 *particulate, adj*—indicates that the material in question has particle-like properties.

3.2.16 *population, n*—the total of all the units of a particular model vacuum cleaner being tested.

3.2.17 *sample, n*—a small, representative group of vacuum cleaners, taken from a large collection (population) of vacuum cleaners of one particular model, which serve to provide information that may be used as a basis for making a determination concerning the larger collection.

3.2.18 *submicrometer, adj*—describes the range of particles having a mean diameter of less than 1  $\mu\text{m}$  ( $1 \times 10^{-6}$  m).

3.2.19 *unit or test unit, n*—a single vacuum cleaner system of the model being tested.

3.2.20 *upstream, adv*—signifies the position of any object or condition that is physically in or part of the airflow stream occurring before the referenced item.

3.2.21 *vacuum cleaner, n*—as defined in Terminology **F395**.

3.3 *Symbols:*

- cfm = cubic feet/minute.
- $D$  = diameter, in.
- ft = feet.
- $^{\circ}\text{F}$  = degrees Fahrenheit.
- Hz = frequency, Hertz.
- $\text{H}_2\text{O}$  = water, column.
- in. = inch.
- psi = pound-force per square inch.
- $Q$  = airflow rate, cubic feet/minute.
- RH = relative humidity.
- RMS = root mean square.
- s = second.
- $\bar{X}$  = population mean.
- $X_i$  = test unit average.
- $\mu\text{m}$  = micrometre ( $10^{-6}$  m).
- % = percent.

**4. Summary of Test Method**

4.1 This test method provides a procedure to determine the initial, fractional, filtration efficiency of a vacuum cleaner system (system filtration efficiency). The effects of the downstream concentration of particles that may be caused by various factors

<sup>5</sup> Hinds, William C., *Aerosol Technology—Properties, Behavior, and Measurement of Airborne Particles*, John Wiley & Sons, 1982, ISBN 0-471-08726-2.

<sup>6</sup> Willeke, Klaus, and Baron, Paul A., *Aerosol Measurement—Principles, Techniques, and Applications*, John Wiley & Sons, formerly Van Nostrand Reinhold, 1993, ISBN 0-442-004486-9.

including the electric motor(s) used in the vacuum cleaner are counted as part of the test method. The report on the results of the testing will indicate if these downstream counts were included or were mathematically removed in the determination of the initial fractional efficiency.

4.2 In determining a vacuum cleaner system's initial, fractional, filtration efficiency, the test unit is placed in a test chamber, and sealed from ambient conditions. In this test chamber, a large, controlled volume of HEPA filtered air (meeting HEPA standards as defined by ~~IES-RC-CC021-1~~) IEST-RP-CC001) is passed over and around the test unit. A controlled aerosol challenge is introduced into the vacuum cleaner system. Upstream and downstream, air sampling measurements of the number and sizes of particles, within six particular ranges (channels), are acquired on a near, real time basis. The initial, fractional, filtration efficiency values at six incremental sizes are then calculated.

## 5. Significance and Use

5.1 It is well known that modern electrical appliances, incorporating electric motors that use carbon brushes for commutation, may emit aerosolized, particles into the surrounding environment. This test method determines the initial, fractional, filtration efficiency of a vacuum cleaner system, taking those emissions into consideration.

5.2 For all vacuum cleaner systems tested, the total emissions of the unit, whatever the source(s), will be counted at each of the six particle size levels identified in the test procedure. This test method determines the initial, fractional filtration efficiency of a vacuum cleaner system, with or without the motor emissions mathematically removed in the calculation of efficiency.

## 6. Apparatus

6.1 The information provided in this test method is intended to enable a laboratory to design, fabricate, and qualify the various components utilized in this procedure. Detailed and specific information regarding the components, a set of construction drawings, photos, vendor information, assembly, calibration, qualification testing instructions, and so forth, are not provided.

### 6.2 Laboratory Filtration Test Room:

6.2.1 The laboratory shall be maintained at  $70 \pm 5^\circ\text{F}$  and 35 to 55 % RH.

6.2.2 ~~To maintain the required ambient conditions within the laboratory and the test chamber, the test chamber airflow may be recirculated through the laboratory, in a closed-loop fashion. The air should pass through a HEPA filtration system before exhausting into the laboratory.~~

6.2 *Main Test Chamber*—The test chamber is mounted in a vertical attitude and shall be capable of enclosing the vacuum cleaner which is to be mounted in a horizontally, centralized position that will allow the test chamber sheath air to flow over and around it. Shown diagrammatically in Fig. 2, the body of the chamber is between approximately ~~2.52.5~~ 2.5 ft and 3 ft in diameter (a rectangular chamber may be used) by approximately ~~44~~ 44 ft to 5 ft in height, which is considered adequate for testing household and commercial vacuum cleaners as identified in the scope. The test chamber is fabricated from aluminum or stainless steel and shall be electrically connected to an earth ground. A large access panel or door shall be provided to accommodate the installation of the test unit. This door shall have a peripheral seal to ensure against the loss of aerosolized, challenge particles during testing. A removable wire form grill, capable of supporting the test unit, shall be placed at or near the bottom of the test chamber (opening space 2 in. (50 mm) or greater; ~~0.2-in. diameter rod or less;~~ open area 80 % or greater).

6.3 *Sheath Air Supply*—The test chamber's sheath airflow shall be produced by a positive pressure blower system. The sheath air is introduced into the top of the test chamber through a manifold and diffuser section in a manner to ensure a velocity profile across a horizontal plane, at the middle of the chamber, that is within 10 % of the maximum velocity measured at any point on that plane, when measured at chamber flow rates of ~~100 and 1000 cfm;~~ cfm or greater; in accordance with the procedure described in Test Method D3154.

6.3.1 The HEPA-rated filtration section and the test chamber's air supply, blower system shall be sized to provide a minimum airflow of ~~4000~~ 100 cfm at the load previously described.

6.4 *Challenge Injection System*—Air entering the test chamber at any point or for any purpose, unless specifically stated otherwise, shall initially pass through a HEPA filter. (HEPA filtration specifications are found in ~~IES-RP-CC021-1~~) IEST-RP-CC001 or ISO 29463-1.)



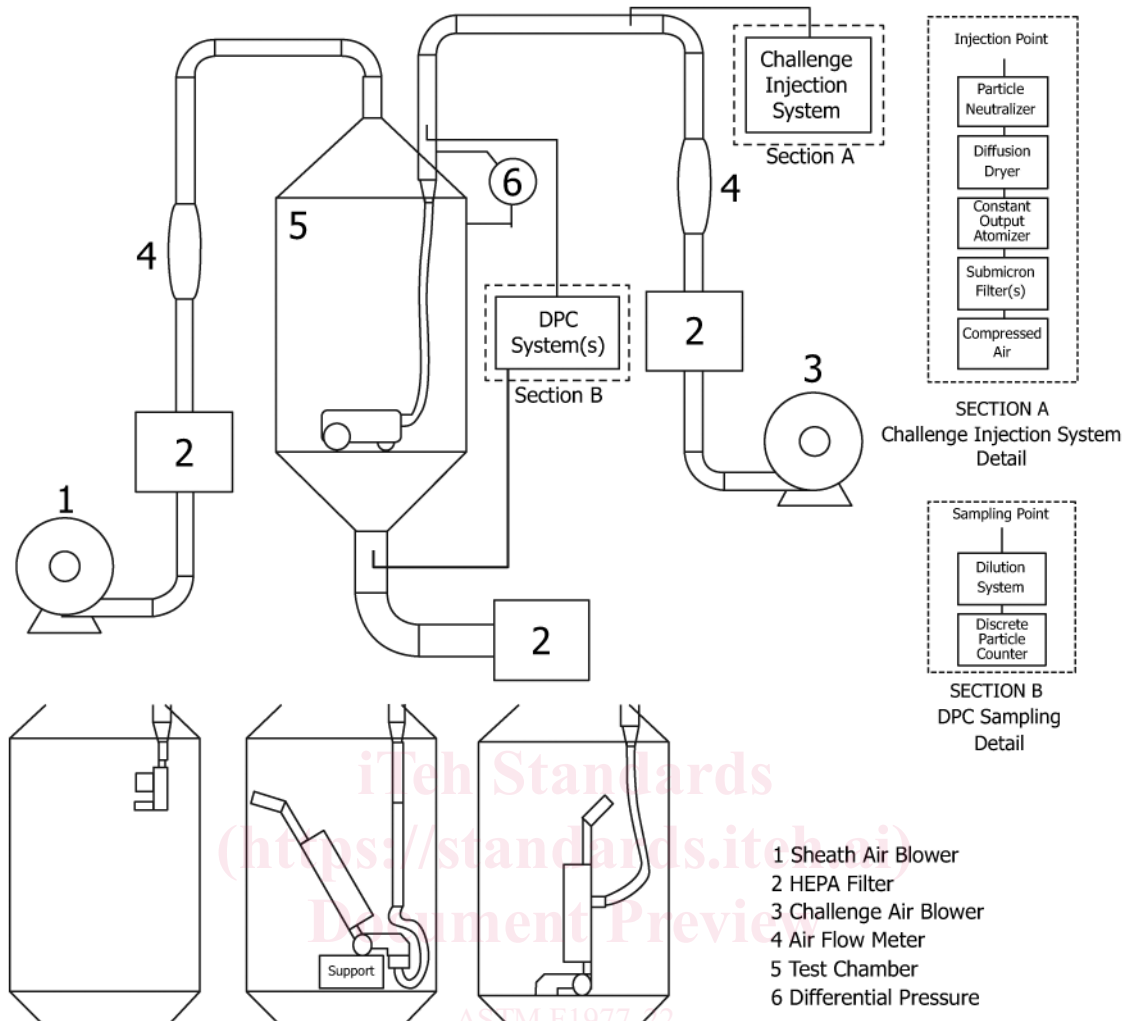

FIG. 2 Filtration Test Chamber and Supporting Equipment

6.4.1 An atomizing system (challenge feeder) is required to inject the challenge at a constant rate equal to  $\pm 5\%$  of the concentration level required during the data acquisition period. This system is supported with equipment and components to supply the required concentration level of aerosol at a maximum 20 % relative humidity.

6.4.2 The atomizer shall be designed to generate polydisperse aerosols (in particular potassium chloride (KCl)) with the ability to generate sufficient particles in the 0.3 to 3.75- $\mu\text{m}$  ranges as specified in [12.3.211.3.2](#).

6.4.3 A source of high pressure, HEPA-filtered, clean dry air is provided to the challenge feed system. This air supply shall be regulated to  $\pm 1$  psi and operator controlled between 0 and 80 psi.

6.4.4 Control of the challenge concentration level shall be provided to ensure that the upstream air sampling concentration level does not produce coincidence errors in the upstream DPC. Any control means that does not introduce extraneous contaminants or change the characteristics of the challenge, or the air stream which is transporting it, may be used. A procedure to determine the maximum concentration limit is provided in [Annex A4](#). The amount of challenge for a particular particle size should not exceed 1 million counts upstream.

6.4.5 The challenge passes through a dryer prior to entering the neutralizer. A dryer providing a maximum 20 % relative humidity at its exit is required. The humidity probe is located in may be inserted into the dryer; therefore, the air velocity will not affect the humidity measurement.

6.4.6 After drying, the challenge aerosol shall pass through a krypton-85, gas-charged neutralizer-neutralizing device to neutralize

or discharge the aerosol to Boltzmann equilibrium. The neutralization may be accomplished with any device capable of reducing the charge of the particulate to less than  $\pm 1000$  ions/cc.

NOTE 1—Adequate neutralizing of particulate has been demonstrated with a variety of methods including the use of a krypton-85 gas-charged neutralizer and with electrostatic devices.

6.4.7 All air sampling and air handling tubes, positioned downstream of the neutralizer and upstream of the air sampling DPC, shall be metallic or elastomeric tubes with ~~metallic liners—liners~~ or antistatic properties. In either case, these tubes shall be earth grounded.

6.4.8 A metallic injector tube with a smooth interior wall is ~~mounted vertically inside~~ connected in a vertical orientation to the test chamber so that the outlet is positioned above and in close proximity to the inlet point of the test vacuum cleaner. The challenge aerosol is injected into the top of the injector tube, through a dispersion means, to ensure a particle concentration profile, across the diameter of the tube at the position of the probe, that shall be within  $\pm 3\%$  of the measured, maximum particle concentration when the injector tube is operating at steady state conditions of ~~50 and 100 cfm~~ 50 cfm and 100 cfm (23.5 lps and 47 lps) flow rates. This section of pipe will support the thin-walled sampling probe which shall be mounted in a position to ensure its proper function.<sup>5,6</sup>

6.4.8.1 Operating at the specified, normal airflow rate, the injector tube shall be sized to produce turbulent flow. The thin-walled probe and airflow metering device shall be mounted within this tube section in positions to ensure their proper functioning.

(1) The injector tube should be ~~approximately at least~~ 2-in. (50 mm) diameter and 24 in. (610 mm) long; fabricated from aluminum, stainless steel, or steel with a rust-preventative coating; and shall be earth-grounded.

(2) The airflow metering device shall have an accuracy of  $\pm 2\%$  with a full-scale reading of not more than two times the normal airflow, and readability to ~~1 cfm~~ 1 lps.

NOTE 2—This recommended configuration will satisfy the normal airflow requirements for most known vacuum cleaners and is considered a practical size for mounting within the test chamber cleaners. However, a laboratory may require several injector tubes, configured differently, to satisfy the entire range of testing conditions it could experience.

6.4.8.2 The HEPA-filtered air enters the top of the injector tube. The airflow ~~can be produced by a DPC vacuum pump, the vacuum cleaner, the vacuum cleaner shall be assisted by an auxiliary air blower, or any combination of those elements. In some cases, such as testing a secondary motor, an auxiliary blower is required.~~ blower.

(1) The injector tube's auxiliary blower system shall be sized to minimally provide any additional airflow required to make up for the losses caused by the injector tube and any plastic tubing and the nozzle adaptor (discussed as follows), when the test unit is to be operating at normal airflow. The auxiliary air blower shall be adjusted until the differential pressure measured between the injection tube (that is, upstream channel) near the connection to the vacuum cleaner and the main test chamber is  $-0.1(+0.0/-0.1)$  in  $H_2O$  ( $-25$  Pa).

NOTE 3—During the sequence of determining the background particle counts, normal airflow through the injector tube is not required. Any background particle counts in the injector tube are insignificant and will be counted with the challenge.

6.4.8.3 The neutralized challenge and feed air shall be fed into the vacuum cleaner through the integral hose of the product, if present.

6.4.8.4 Should the vacuum cleaner, under test, not have an integral hose, a nozzle adapter (Fig. 1) shall be constructed with a flexible tube attached to allow connection to the injector tube. The flexible tube, transporting the challenge aerosol from the outlet of the injector tube to the vacuum cleaner, by means of a nozzle adaptor, shall not be longer than 2 times the distance between the end of the injector tube and the inlet to the nozzle adaptor. An elastomeric tube having an earth-grounded, metallic liner shall be used. This flexible tube shall be conductive and be earth-grounded. The inside diameter of this tubing shall not be less than  $\frac{1}{4}$  in.; the wall of the tubing shall not be less than  $1.5 \frac{1}{4}$  in. (38 mm). The tubing shall not be allowed to kink between the end of the injector tube and the inlet to the nozzle adaptor. The interfacing connections of this tube, to the outlet of the injector tube and the inlet of the nozzle adaptor, are to be sealed and constructed to ensure no loss of challenge particles or dilution of the challenge concentration.

NOTE 4—Because the tubing and connections may be operating under negative or positive pressure depending upon the testing conditions, aerosol losses could occur from mechanical means due to improper construction of the joints, and dilution could occur from leaks.



(*H*) The injector tube's blower system shall be sized to minimally provide any additional airflow required to make up for the losses caused by the injector tube, plastic tubing, and the nozzle adaptor (discussed as follows), when the test unit is to be operating at normal airflow. A blower system with the following performance characteristics should be expected to satisfy most test conditions: sealed suction in excess 100 in. H<sub>2</sub>O and airflow in excess of 100 cfm at a 2-in. orifice as determined in accordance with Test Method **F558**.

(*I*) The nozzle adaptor (a rectangular-shaped box acting as a plenum chamber; see **Fig. 1**) is securely attached and sealed to the vacuum cleaner's nozzle. The nozzle adaptor may be fabricated from any suitable, non-porous, rigid construction materials. The seal between the nozzle and the nozzle adaptor shall be leak-free. The nozzle adaptor shall not interfere with the operation of any mechanisms that may be present in the test unit's nozzle, for example, a rotating agitator, bristle brush. The inside, cross-sectional shape and size of the nozzle adaptor is to conform to the inside, perimeter dimensions of the test unit's nozzle. The nozzle adaptor's inside height, in a direction perpendicular from the face of the nozzle, is to be 4.0 in. ±0.5 in. (100 mm ±12 mm). The flexible tube from the injector tube, is to enter the nozzle adaptor through the center of any one of the three larger surfaces and shall not extend inside the chamber by more than ½ in. (see **11.2** to **11.2.7.5**).

**NOTE 3**—During the sequence of determining the background particle counts, normal airflow through the injector tube is not required. Any background particle counts in the injector tube are insignificant and will be counted with the challenge.

6.5.9 The nozzle adaptor (a rectangular-shaped box acting as a plenum chamber; see **Fig. 1**) is securely attached and sealed to the vacuum cleaner's nozzle. The nozzle adaptor may be fabricated from wood or other suitable construction materials. The seal between the nozzle and the nozzle adaptor shall be leak-free. The nozzle adaptor shall not interfere with the operation of any mechanisms that may be present in the test unit's nozzle, for example, a rotating agitator, bristle brush. The inside, cross-sectional shape and size of the nozzle adaptor is to conform to the inside, perimeter dimensions of the test unit's nozzle. The nozzle adaptor's inside height, in a direction perpendicular from the face of the nozzle, is to be 4 ± ½ in. The flexible tube from the injector tube, is to enter the nozzle adaptor through the center of any one of the three larger surfaces and shall not extend inside the chamber by more than ½ in. (see **12.2** to **12.2.8.5**).

#### 6.5 Lower Chamber:

6.5.1 The truncated extension at the bottom of the test chamber reduces the test chamber's horizontal cross section, perpendicular to the direction of airflow, resulting in an increase in the air stream velocity through the metallic, lower pipe section placed at the bottom of this truncated section.

6.5.2 The diameter of the lower pipe section should be approximately 6 in. to 8 in. This will produce a desirable, turbulent flow without greatly restricting the test chamber airflow. This section of pipe will support the downstream, air sampling, thin-walled probe which shall be mounted in a position to ensure its proper function.<sup>5,6</sup> The minimum length for this pipe section shall be no less than 2 ft-ft (610 mm). Aerosol passing through this pipe at the location of the probe, shall have a concentration profile across the pipe diameter that does not vary by more than 3 % from the maximum measured concentration level when the test chamber is operating under steady-state flow conditions of ~~100 and 1000 cfm.~~ 100 cfm.

6.5.3 The air duct system, downstream from the lower pipe section, may be of any appropriate material and may include air straighteners, filters, and so forth, to accommodate airflow measurement devices placed in this duct section to measure and monitor the test chamber's airflow. A minimum, 6-in. (150 mm) diameter pipe should be used.

#### 6.6 Discrete Particle Counter(s):

6.6.1 At least one discrete particle counter (DPC), supported by computer equipment, software, and other peripherals, is required.

6.6.1.1 The three possible test conditions, described in this test method, may utilize either a one- or two-DPC system.

6.6.1.2 The DPC system may acquire air samples through a switching valve system.

**NOTE 5**—When using either DPC system, the total operational times of the test unit during the ~~test run~~ trial will be identical to ensure that the unit is subjected to the same operating conditions in both situations. This will result in different ~~test run~~ trial times; see ~~12.13.1~~ **11.22.1** and its sub-paragraphs.

(*I*) In a system using two DPCs, ~~capable of simultaneously switching from sampling one probe to the other, the~~ the need to develop a correlation ratio between the two DPCs and apply it when determining the initial, fractional, filtration efficiency is discussed in **Annex A5**. When a correlation ratio is required, it shall be used in the determination of the fractional efficiency. ~~It~~

most cases, it can be expected that the need will be negated because any difference between the two DPCs and the sampling lines would be canceled out in the switching process.

(2) For the single DPC system switching process, an electrical-a mechanical valve system should be used in both DPC systems may be used to switch between sampling probes allowing sufficient time to flush the sampling line between counting periods.

(3) DPC equipment is extremely sensitive to high concentrations of, and cumulative exposure to, any aerosolized particles.

(4) DPC equipment is sensitive to high-moisture conditions and water vapor.

(5) Particle size measurement is a function of both the actual particle dimension or shape factor, or both, as well as the particular physical or chemical properties of the particle being measured. Caution is required when comparing data from instruments operating on different physical or chemical parameters or with different particle size measurement ranges. Sample acquisition, handling, and preparation can also affect the reported particle size results.

6.6.1.3 The minimal requirements of the DPC system to be used for this procedure are as follows:

Sizing sensitivity	≥0.3 μm
Sample flow rate	≤1.0 cfm nominal; user adjustable within ±20 %
Concentration limit	≥ a minimum 1 000 000 particles/ft <sup>3</sup> with less than 10 % coincidence error at the concentration limit
Concentration limit	≥ 1 000 000 particles/ft <sup>3</sup> with less than 10 % coincidence error at the concentration limit
Operating principle	Laser optics
Sizing information	≥8 channels, user selective
Sizing information	≥6 channels, user selective

#### 6.7 Dilution System:

6.7.1 A dilution system in both the upstream and downstream sampling line may be required to maintain the DPC concentration level below the limit established in this test method.

6.7.1.1 If the dilution system reduces particle concentration by injecting air into the sampling line, this air shall be filtered through a HEPA filter.

6.7.1.2 An airflow meter that is at least equivalent in accuracy and readability to that used in the DPC shall be used to monitor the dilution airflow.

NOTE 6—Development of a large, upstream particle count is highly desirable so that meaningful downstream counts are established. When testing units which have a high motor emissions count, overconcentrating the downstream DPC may dictate the use of a dilution system. The use of any dilution means will sacrifice precision in the calculation of efficiency. In those cases where high motor emissions are present, the number of test runs/trials required to reach 95 % confidence may become high.

#### 6.8 Other Equipment:

6.8.1 *Digital Display Humidity Meter*, used for qualification and verification of the various air supplies. Accuracy: minimum ±3 % at 78°F/70°F between 20 and 90 % of range. Display resolution: ±1 % RH. Response time: 15 s for a 60 % step change in moving air.

6.8.2 *Voltmeter*, to measure rated input volts to the vacuum cleaner; capable of providing measurements accurate within ±1 % of the vacuum cleaner's rated input voltage.

6.8.3 *Voltage Regulator System*, to control the input voltage to the vacuum cleaner. The regulator system shall be capable of maintaining the vacuum cleaner's rated voltage ±1 % and rated frequency having a wave form that is essentially sinusoidal with ±3 % maximum harmonic distortion for the duration of the test.

6.8.4 *Thin-Walled Probes* of various sizes may be required to accommodate the flow requirements of the DPC(s). The probes shall be sized to meet the performance requirements-isokinetic sampling requirements. Isokinetic sampling requires that the velocities of 12.4 air flows in the sampling channels,  $v_{channel}$  and its depending, sub-paragraphs, and at the entry of the sampling system,  $v_{probe}$ , shall satisfy the relation:

$$0,8 < \frac{V_{\text{probe}}}{V_{\text{channel}}} < 1,2 \quad (1)$$

6.8.4.1 Probes are to be located and properly mounted in the middle center of the airstream of their respective ~~ducts~~ ducts with their inlets oriented perpendicular to the direction of airflow.<sup>5</sup>

6.8.4.2 The output of each probe shall be channeled to the DPC through earth-grounded, smooth bore, metallic tubing. Electrically conductive, plastic tubing with the conductive layer being earth-grounded may also be used. The tubing shall convey the aerosol sample to the DPC through the shortest practical ~~distance~~ distance ( $\leq 1$  m). In all cases, the inlet to the DPC shall be physically positioned below the ~~probes outlet and not more than 2 ft from the vertical center line of the test chamber probes~~. All bend radii from the probe to the DPC shall be greater than 10 times the inside diameter of the ~~tubing which shall be sized so that high-velocity flow conditions exist (Reynolds number 4000 or larger)~~ tubing.

6.8.5 *Time Measuring Device*, accurate to 1 s.

6.8.6 *Air Ion Counter*, with a range of 2 million ions/cc and resolution of 10 ions/cc. The accuracy is to be at least  $\pm 25$  % of reading.

## 7. Materials

7.1 A solution of KCl and distilled or demineralized water as required by the aerosol generator.

7.1.1 *KCl* (potassium chloride, pure).

7.1.2 *Reagent Water*, Type IV, grade in accordance with Specification Designation **D1193**.

7.2 *Latex (Polystyrene) Spherical Particles*, traceable to the National Institute of Standards and Technology, (NIST) used for the calibration or verification, or both, of the DPC.

7.2.1 The ~~proper concentration level of latex spheres shall be used in the aerosol generator as discussed in *Aerosol Measurement Principles, Techniques, and Applications*, p. 63-64.~~<sup>7</sup>

## 8. Hazards [standards.iteh.ai/catalog/standards/sist/33e80919-b990-4054-b4d1-1af611923ce6/astm-f1977-22](https://standards.iteh.ai/catalog/standards/sist/33e80919-b990-4054-b4d1-1af611923ce6/astm-f1977-22)

8.1 **Warning**—DPC equipment is extremely sensitive to high concentrations of, and cumulative exposure to, any aerosolized particles.

8.2 **Warning**—DPC equipment is sensitive to high moisture conditions and water vapor.

8.3 **Warning**—Particle size measurement is a function of both the actual particle dimension or shape factor, or both, as well as the particular physical or chemical properties of the particle being measured. Caution is required when comparing data from instruments operating on different physical or chemical parameters or with different particle size measurement ranges. Sample acquisition, handling, and preparation can also affect the reported particle size results.

## 8. Sampling

8.1 To determine the best single estimate of the initial, fractional, filtration efficiency for the population of the vacuum cleaner model being tested, the arithmetic mean of the fractional efficiency ratings of the individual units from a sample of the population shall be established by testing the necessary quantity of units from the sample population, to a 90 % confidence level within  $\pm 5$  % of the mean value of the fractional efficiency, for each particle size required.

8.1.1 A minimum of three units/samples (of the same model vacuum cleaner), selected at random in accordance with good statistical practice, shall constitute the population sample.

8.2 For each particle size required, the mean initial, fractional, filtration efficiency of the individual test unit is established by

performing the necessary number of ~~test runs—trials~~ to reach a 95 % confidence level within  $\pm 5$  % of the mean value of the measurements acquired per particle size from all of the ~~test runs—trials~~. For each particle size, the mean efficiency of the test unit is then recorded as the best estimate of the initial, fractional, filtration efficiency of that unit and is utilized to calculate the mean initial, fractional, filtration efficiency for the population sample.

NOTE 7—A minimum of three trials is generally sufficient to achieve the 95 % confidence requirement, but more may be necessary due to variations in sample quality.

8.2.1 For particles sizes having less than 50 counts, the statistics are based upon the Poisson distribution (see **Annex A1**). For counts greater than 50, use Binomial statistics (see **Annex A2**).

## 9. Calibration, Qualification, and Standardization

9.1 Unless otherwise stated in this test method or the annexes, the maximum frequency of calibration or qualification, or both, of the equipment used in this test method is to be based upon the equipment manufacturer's specification. Calibrate or qualify all other equipment based on quality laboratory practices set forth in ~~ISO/DIS~~ISO/IEC 17025.

9.1.1 Calibrate or qualify individual equipment pieces, or both, when abnormal performance of the specific piece is noted or suspected.

9.2 Monitor the high-pressure air supply for the challenge feeder or any dilution system for conformance to humidity and air quality requirements every six months, or immediately if contamination is suspected.

9.3 Calibrate all other equipment, not specifically identified, at least every six months.

## 10. Conditioning

10.1 Maintain the laboratory in which all conditioning and testing will be performed, at  $70 \pm 5^\circ\text{F}$  ( $21 \pm 3^\circ\text{C}$ ) and 35 to 55 % relative humidity.

ASTM F1977-22

10.2 All components involved in this test method are to remain in and be exposed to the controlled environment for a minimum of 16 h prior to the start of the test.

10.3 To stabilize the vacuum cleaner's motor emissions, operate the vacuum cleaner system's motor(s) at nameplate rated voltage ( $\pm 1$  %) and rated frequency ( $\pm 1$  Hz), with unimpeded airflow for a minimum of 3 h or (or longer if required—required). For vacuum cleaners with dual nameplate voltage ratings, ~~conduct the run in—condition~~ the vacuum cleaner samples at the highest rated voltage.

10.3.1 Determine stabilization by operating the test unit in the test chamber and monitoring the downstream counts. Stabilization requirements are defined in the Terminology section.

## 11. Fractional Filtration Efficiency Test Procedure

11.1 If the motor emissions are to be excluded from the efficiency calculations used to determine the vacuum cleaner system's initial, fractional, filtration efficiency, do not operate any secondary motor in the vacuum cleaner system during the ingestion of the challenge. However, if the motor emissions are to be included in the efficiency calculations used to determine the vacuum cleaner's initial, fractional, filtration efficiency, any secondary motor in the vacuum cleaner system must be operated—shall be operated as recommended in the vacuum cleaner's user guide during the ingestion of the challenge.

~~12.1.1 For those units incorporating the secondary motor in a separate attachment (for example, a powered nozzle in a canister vacuum cleaner system), mount this attachment and the connecting hose and wands in the test chamber, as described as follows. Power to the secondary motor may be disconnected during the ingestion of the challenge to aid in reducing the downstream particle count if motor emissions are to be excluded from the efficiency calculations. However, if motor emissions are to be included in the efficiency calculations, all secondary motors must be connected to power and be energized during testing.~~