

INTERNATIONAL  
STANDARD

**ISO**  
**5263**

Second edition  
1995-06-01

---

---

**Pulps — Laboratory wet disintegration**

*Pâtes — Désintégration humide en laboratoire*

**iTeh STANDARD PREVIEW**  
**(standards.iteh.ai)**

[ISO 5263:1995](https://standards.iteh.ai/catalog/standards/sist/63e02703-bd72-45b7-98e3-bf853ea1fd2/iso-5263-1995)

<https://standards.iteh.ai/catalog/standards/sist/63e02703-bd72-45b7-98e3-bf853ea1fd2/iso-5263-1995>



Reference number  
ISO 5263:1995(E)

## Foreword

ISO (the International Organization for Standardization) is a worldwide federation of national standards bodies (ISO member bodies). The work of preparing International Standards is normally carried out through ISO technical committees. Each member body interested in a subject for which a technical committee has been established has the right to be represented on that committee. International organizations, governmental and non-governmental, in liaison with ISO, also take part in the work. ISO collaborates closely with the International Electrotechnical Commission (IEC) on all matters of electrotechnical standardization.

Draft International Standards adopted by the technical committees are circulated to the member bodies for voting. Publication as an International Standard requires approval by at least 75 % of the member bodies casting a vote.

iteh STANDARD PREVIEW  
(standards.iteh.ai)

International Standard ISO 5263 was prepared by Technical Committee ISO/TC 6, *Paper, board and pulps*, Subcommittee SC 5, *Test methods and quality specifications for pulps*.  
<https://standards.iteh.ai/catalog/standards/sist/63e02703-bd72-45b7-98e3-bf853ea1fd2/iso-5263-1995>

This second edition cancels and replaces the first edition (ISO 5263:1979), of which it constitutes a technical revision.

Annexes A and B form an integral part of this International Standard.

© ISO 1995

All rights reserved. Unless otherwise specified, no part of this publication may be reproduced or utilized in any form or by any means, electronic or mechanical, including photocopying and microfilm, without permission in writing from the publisher.

International Organization for Standardization  
Case postale 56 • CH-1211 Genève 20 • Switzerland

Printed in Switzerland

# Pulps — Laboratory wet disintegration

## 1 Scope

This International Standard specifies an apparatus and a method for the laboratory wet disintegration of pulp. It specifies the disintegration apparatus and in some cases the disintegration procedures required in a number of other International Standards dealing with pulps.

In principle, this method is applicable to most kinds of pulp, including recycled fibres. It is not suitable for some very long-fibred pulps such as those from cotton and similar materials; it is not recommended for the removal of latency from mechanical pulps (see footnote 3, of table 1).

## 2 Normative references

The following standards contain provisions which, through reference in this text, constitute provisions of this International Standard. At the time of publication, the editions indicated were valid. All standards are subject to revision, and parties to agreements based on this International Standard are encouraged to investigate the possibility of applying the most recent editions of the standards indicated below. Members of IEC and ISO maintain registers of currently valid International Standards.

ISO 638:1978, *Pulps — Determination of dry matter content*.

ISO 4119:1995, *Pulps — Determination of stock concentration*.

## 3 Definition

For the purposes of this International Standard, the following definition applies.

**3.1 disintegration of a pulp sample:** Mechanical treatment in water so that interlaced fibres, which were free in the pulp stock, are again separated from one another without appreciably changing their structural properties.

## 4 Apparatus

Ordinary laboratory apparatus and

**4.1 Disintegrator**, as described in annex A.

**4.2 Balance**, capable of weighing the sample with an accuracy of  $\pm 0,2$  g.

## 5 Preparation of sample

If the pulp is wet or air-dry, weigh out a sample for dry matter determination in accordance with ISO 638. If the pulp is in slush form, determine the dry matter content in accordance with ISO 4119.

Take the amount of pulp specified in table 1. Do not cut the pulp and avoid taking cut edges. Pulps having a dry matter content equal to or greater than 20 % (*m/m*) shall be soaked in 1 litre to 1,5 litres of water at  $20\text{ °C} \pm 5\text{ °C}$  (see notes 1 and 2) for the time specified in table 1. If the pulp is in the form of sheets or slabs, tear the soaked pulp into pieces of dimensions approximately 25 mm  $\times$  25 mm.

### NOTES

1 The type of water to be used should be of same quality as that required in the test for which the pulp is disintegrated.

2 Where necessary for climatic reasons, a temperature of  $25\text{ °C} \pm 5\text{ °C}$  may be applied, provided that this is noted in the test report.

## 6 Procedure

Transfer the sample into the container of the disintegrator (4.1). Add water at  $20\text{ °C} \pm 5\text{ °C}$  (see clause 5, notes 1 and 2) to give the total volume specified in table 1 (if the concentration of a slush pulp sample is less than 1,5 % (m/m), it may be thickened to the appropriate volume, carefully avoiding the loss of fines). Set the revolution counter to zero. Switch the motor on and allow the propeller to make the number of revolutions specified in table 1. Stop the propeller and check visually that the pulp is completely disintegrated. If it is not, the disintegration may be continued until complete separation of fibres is achieved.

## 7 Test report

The test report shall include the following particulars:

- reference to this International Standard;
- all the indications necessary for complete identification of the sample;
- the soaking time;
- the pulp concentration and the number of revolutions used;
- any unusual features observed in the course of the test;
- any operations not specified in this International Standard, or regarded as optional, which might have affected the results.

# iTeh STANDARD PREVIEW (standards.iteh.ai)

**Table 1 — Summary of recommended disintegration conditions**

ISO 5263:1995

Kind of pulp	Dry matter content % (m/m)	Oven-dried mass of pulp g	Minimum soaking time	Disintegration volume ml	Number of revolutions <sup>1)</sup>
Chemical <sup>2)</sup>	< 20	30	—	2 000	10 000
	20 to 60	30	30 min	2 000	30 000
	> 60	30	4 h	2 000	30 000
Mechanical <sup>2) 3)</sup>	< 20	60	—	2 700	10 000
	20 to 60	60	30 min <sup>4)</sup>	2 700	30 000
	> 60	60	4 h <sup>4)</sup>	2 700	30 000

1) If for any reason a different charge of pulp or a different number of revolutions is used, this shall be noted in the test report.

2) Semichemical and chemical-mechanical pulps may be disintegrated either as chemical or mechanical pulps, depending on the purpose of testing.

3) If this procedure is used for the removal of latency from mechanical pulps, the disintegration of the pulp suspension shall be carried out at an elevated temperature (at least 85 °C).

4) Flash-dried pulps shall be soaked for 10 min only. For other pulps, soaking for a longer time than specified, for example overnight, has not been found to have any significant effect on the results. Soaking time should, however, never be longer than 24 h for any kind of pulp.

## Annex A (normative)

### Construction of the disintegrator

#### A.1 Materials

All components that come into contact with pulp suspensions shall be resistant to water and to dilute acids and alkalis. Stainless steel or glass-fibre-reinforced plastic material is normally used.

#### A.2 Disintegrator (see figure A.1)

The cylindrical container is fitted with four equally spaced spiral baffles extending between 32 mm from the bottom and 57 mm from the lid, each baffle traversing half the internal circumference of the container. The baffles spiral downwards in a clockwise direction. There is a fillet of radius 13 mm around the inside of the base of the container.

The three-bladed propeller is mounted on a vertical shaft centrally in the container, at a fixed distance above the bottom. It is driven at the specified speed in the stock and a counter is fitted to record the number of revolutions; the counter should preferably be of the pre-set type which will switch off the disintegrator after the required number of revolutions. Viewed from above, the propeller rotates in a clockwise direction.

The container is provided with a lid which, in most disintegrators, is fitted to the propeller/motor assembly. The container is fixed firmly in position during operation of the disintegrator, but it is capable of being removed and replaced easily and quickly.

#### A.3 Dimensions

iTeh STANDARD PREVIEW  
(standards.iteh.ai)

Part	Dimension <a href="https://standards.iteh.ai/catalog/standards/sist/63e02703-bd72-45b7-98b3-bf853ea1fd2/iso-5263-1995">ISO 5263:1995</a>	Nominal value (unless otherwise specified)	Tolerance
Container	Internal height Internal diameter Radius of fillet	191 mm 152 mm 13 mm	± 2 mm ± 2 mm ± 2 mm
Baffles	Square section Height from container base Distance from rim Ends radiused Edges radiused Spacing (centres)	6,5 mm 32 mm 57 mm 3 mm 0,4 mm 51 mm	± 1 mm ± 1 mm ± 1 mm ± 0,5 mm ± 0,1 mm ± 1 mm
Propeller	Diameter Diameter of hub Separation blades/container base (lowest point)	90 mm ≥ 22 mm 25 mm	± 0,5 mm ± 2 mm
Propeller blades	Width at hub Maximum width Thickness Edges radiused Ends radiused Pitch	18,2 mm 22,5 mm 1,6 mm 0,8 mm 4 mm 2°	± 0,5 mm ± 0,5 mm ± 0,5 mm ± 0,2 mm ± 1 mm ± 15'
Propeller shaft	Diameter End taper	≤ 20 mm To fit any propeller hub	

#### A.4 Rotational frequency

The rotational frequency of the propeller shaft shall be  $49 \text{ s}^{-1} \pm 1,5 \text{ s}^{-1}$ .

Dimensions in millimetres

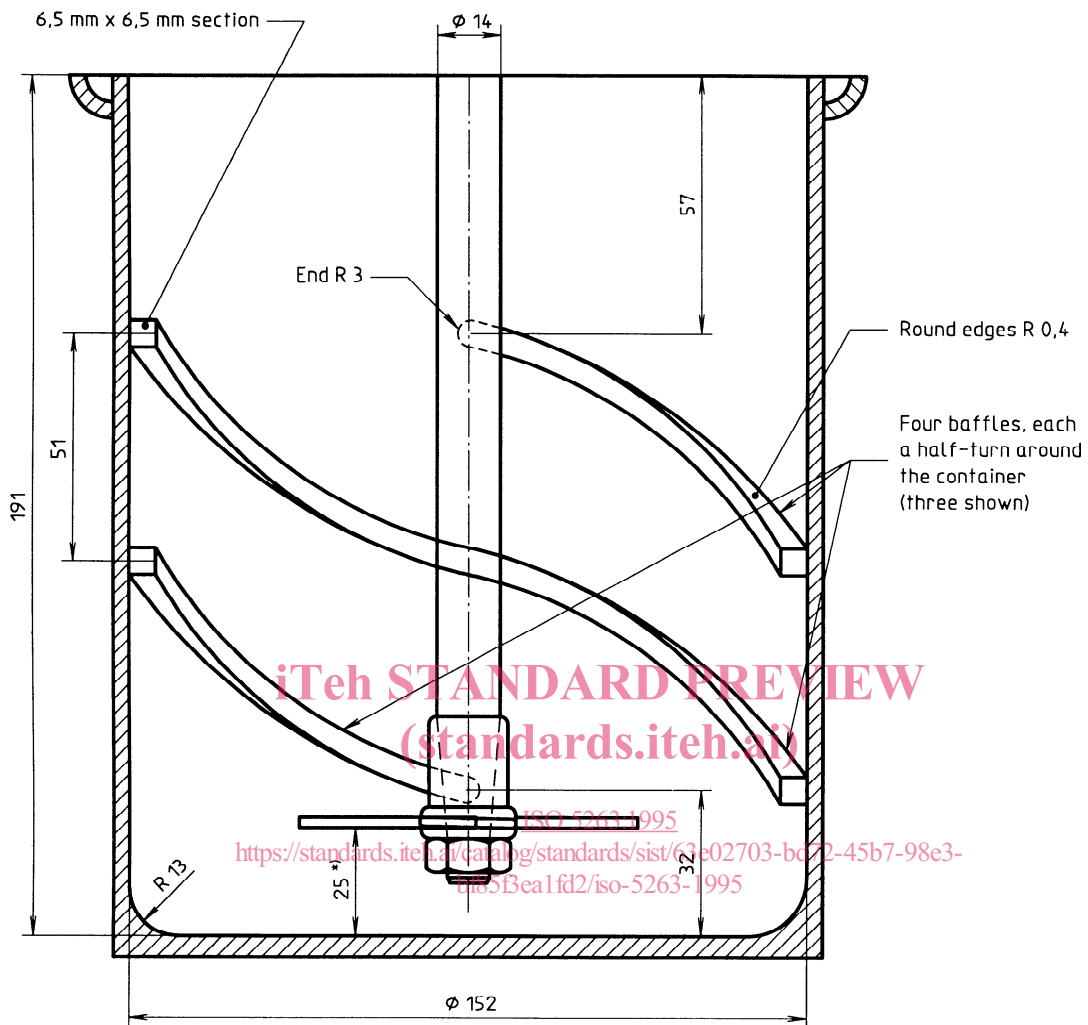

**iTeh STANDARD PREVIEW**  
 (standards.iteh.ai)  
 ISO 5263:1995  
<https://standards.iteh.ai/catalog/standards/sist/63e02703-bc72-45b7-98e3-6b053ea1fd2/iso-5263-1995>

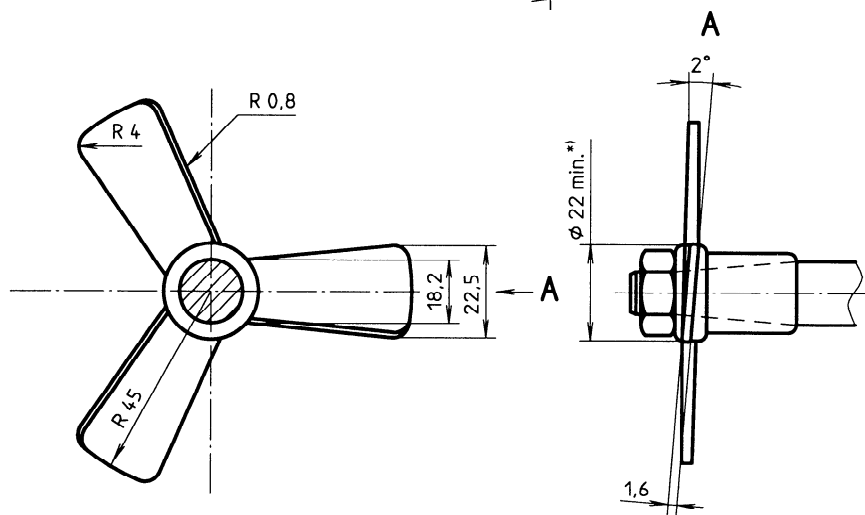

\*1) Not to scale.

Figure A.1 — Disintegrator details

## Annex B (normative)

### Checking of the disintegrator

The disintegrator shall be checked regularly, special care being taken to ensure that

- a) the propeller shaft rotates smoothly and is always centred with respect to the container;
- b) the propeller runs at the specified rotational frequency;

c) the propeller blades are set as specified (this may be checked by means of a propeller gauge);

d) the dimensions of the propeller blades are as specified (see clause A.3).

If the apparatus is used properly, the other dimensions of the disintegrator should remain constant; they shall, however, be checked at intervals.

**iTeh STANDARD PREVIEW**  
**(standards.iteh.ai)**

[ISO 5263:1995](https://standards.iteh.ai/catalog/standards/sist/63e02703-bd72-45b7-98e3-bf853ea1fd2/iso-5263-1995)

<https://standards.iteh.ai/catalog/standards/sist/63e02703-bd72-45b7-98e3-bf853ea1fd2/iso-5263-1995>

**iTeh STANDARD PREVIEW**  
**(standards.iteh.ai)**

ISO 5263:1995

<https://standards.iteh.ai/catalog/standards/sist/63e02703-bd72-45b7-98e3-bf853ea1fd2/iso-5263-1995>

---

---

**ICS 85.040**

**Descriptors:** paper pulps, tests, laboratory tests, disintegration tests, laboratory equipment.

Price based on 5 pages

---

---