



Designation: ~~C1715/C1715M – 21~~ C1715/C1715M – 22

Standard Test Method for Evaluation of Water Leakage Performance of Masonry Wall Drainage Systems¹

This standard is issued under the fixed designation C1715/C1715M; the number immediately following the designation indicates the year of original adoption or, in the case of revision, the year of last revision. A number in parentheses indicates the year of last reapproval. A superscript epsilon (ϵ) indicates an editorial change since the last revision or reapproval.

1. Scope*

1.1 This test method describes a standard procedure for determining the ability of masonry wall drainage systems to collect water that penetrates the exterior masonry wythe during rainstorms and to direct this water back to the exterior surface of the wall.

1.2 This test method is applicable to wall systems that contain an exterior masonry wythe with a drainage zone on the interior face of the exterior wythe. It is not applicable to single-wythe drainage walls.

1.3 This test method is not applicable to masonry barrier walls or other masonry walls that are designed without drainage zones behind the exterior wythe.

1.4 This test method covers the application of the testing using either inch-pound or SI units. The values stated in either SI units or inch-pound units are to be regarded separately as standard. Within the text, the inch-pound units are shown in brackets. The values stated in each system may not be exact equivalents; therefore, each system shall be used independently of the other. Combining values from the two systems may result in nonconformance with the standard.

1.5 *This standard does not purport to address all of the safety concerns, if any, associated with its use. It is the responsibility of the user of this standard to establish appropriate safety, health, and environmental practices and determine the applicability of regulatory limitations prior to use.*

1.6 *This international standard was developed in accordance with internationally recognized principles on standardization established in the Decision on Principles for the Development of International Standards, Guides and Recommendations issued by the World Trade Organization Technical Barriers to Trade (TBT) Committee.*

2. Referenced Documents

2.1 ASTM Standards:²

[C1232 Terminology for Masonry](#)

[C1601 Test Method for Field Determination of Water Penetration of Masonry Wall Surfaces](#)

[E514/E514M Test Method for Water Penetration and Leakage Through Masonry](#)

[E631 Terminology of Building Constructions](#)

¹ This test method is under the jurisdiction of ASTM Committee C15 on Manufactured Masonry Units and is the direct responsibility of Subcommittee C15.04 on Research. Current edition approved Dec. 1, 2021; June 1, 2022. Published December 2021. Originally approved in 2009. Last previous edition approved in 2015 as C1715 – 15; C1715 – 21. DOI: 10.1520/C1715_C1715M-21.10.1520/C1715_C1715M-22.

² For referenced ASTM standards, visit the ASTM website, www.astm.org, or contact ASTM Customer Service at service@astm.org. For *Annual Book of ASTM Standards* volume information, refer to the standard's Document Summary page on the ASTM website.

*A Summary of Changes section appears at the end of this standard



3. Terminology

3.1 *Definitions*—For definitions of terms relating to building construction used in this test method, see Terminology E631. For definitions of terms relating to masonry, brick and clay tile, and concrete masonry units used in this test method, see Terminology C1232.

3.2 *Definitions of Terms Specific to This Standard:*

3.2.1 *back-up wall, n*—the portion of the wall system located on the interior side of the drainage zone.

3.2.2 *drainage zone, n*—the region located between the interior face of the exterior wythe of masonry and the exterior face of the back-up wall or the water-resistive barrier placed on the exterior face of the back-up wall to facilitate the flow of water to a flashing or water collection system.

3.2.2.1 *Discussion*—

The drainage zone often includes other components such as rigid insulation in addition to devices that facilitate the flow of water or prevent mortar from blocking the weeps.

3.2.3 *flashing, n*—an impervious material placed at specified locations in a masonry wall drainage system to collect and direct water penetrating through the exterior wythe of masonry to the exterior face of the exterior wythe of masonry by means of a weep system.

3.2.4 *masonry barrier wall, n*—single or multi-wythe masonry wall system that does not contain a drainage zone directly behind the exterior masonry wythe.

3.2.5 *masonry drainage wall, n*—masonry wall system designed with a drainage zone immediately behind the exterior masonry wythe that allows water penetrating the masonry to flow down the drainage zone where the water is collected and diverted by flashing to the exterior face of the exterior wythe or collected and drained by some other water collection system.

3.2.5.1 *Discussion*—

This wall type includes: masonry cavity walls; anchored masonry veneer walls; insulated cavity walls; and any other masonry wall systems with a drainage zone.

3.2.6 *masonry wall drainage system, n*—the drainage zone, the water resistive barrier (where included), the flashing or other water collection devices, and the weep system in a masonry drainage wall designed to collect water that penetrates the exterior masonry wythe and direct it back to the exterior face of the exterior masonry wythe.

3.2.7 *masonry wall system, n*—all components of an exterior wall including the exterior masonry wythe, wall ties or anchors, the drainage system (if included), the back-up wall, insulation, and wall finishes.

3.2.7.1 *Discussion*—

By definition in this standard, a masonry wall system shall consist of at least an exterior masonry wythe exposed to weather.

3.2.8 *water leakage, n*—penetration of water beyond the innermost plane bounding the masonry wall drainage system or water penetration below or behind flashings.

3.2.9 *water collection system, n*—a trough system or similar system at the base of a drainage zone or a portion of that trough system, used in place of flashing, intended to collect any water that penetrates the exterior wythe of masonry and direct that water to a drainage system.

3.2.10 *water resistive barrier, n*—a coating or membrane on the exterior surface of the back-up wall that is intended to prevent water, which has penetrated the exterior masonry wythe and has bridged the air space, from reaching the surface of the back-up wall and to direct this water into the flashing or water collection system below.

3.2.11 *weep system, n*—a series of openings, tubes, wicks, vents, or other devices at the top surface of the flashing that facilitate the flow of water that collects on the flashing back to the exterior surface of the wall.



4. Summary of Test Method

4.1 This test method introduces water directly into the masonry wall drainage system through holes drilled in the exterior masonry wythe. Water is introduced along the interior face of the exterior masonry wythe by means of hoses at each entry point. These hoses are connected to a common water source. The flow rates are controlled by flow regulators attached to each of the entry point hoses or to a manifold that distributes water uniformly to multiple hoses. This standard sets limits for several parameters to control the velocity and volume of the water at points of entry as well as limits on the maximum spacing of entry points to provide uniform distribution of water along the interior face of the exterior masonry wythe. Interior and exterior observations are performed before, during, and after the test to detect water leakage and to observe the discharge of water to the exterior.

5. Significance and Use

5.1 This test method is suitable for use on walls to determine the ability of masonry wall drainage systems to collect water penetrating the exterior wythe and to direct this water back to the exterior surface of the exterior wythe. Removal of a portion of the interior wall finishes is desirable to observe leakage into backup walls. Even with removal of interior finishes, in many cases it is not practical to observe surfaces behind spandrel beams, columns, or other obstructions. Potential areas where leakage may occur but that are not visible during the test shall be considered when interpreting the results of the test and shall be recorded in the report.

5.2 This test method is suitable for use on mock-up walls to determine the performance of masonry wall drainage systems.

5.3 This test method is suitable for evaluating the effectiveness of flashing repairs.

6. Apparatus

6.1 Major Components:

6.1.1 *Water Source*—a source of potable water under pressure such as the local pressurized water supply, a water supply connected to a pump, or water from an elevated storage tank.

6.1.2 *Flow Meter*—a device capable of measuring the water flow with sufficient accuracy to meet the permitted variations listed in Section 7. The flow meter shall be either integral with or following the flow regulator. Flow meters are connected to each water entry point (Type 1 as shown in Fig. 1). If all water entry points are located within 13 mm [0.5 in.] from the average height of water entry points, the flow meter is permitted to be attached to a distribution manifold connected to multiple entry points (Type 2 as shown in Fig. 2) provided the top of the distribution manifold is located at least 250 mm [10 in.] below the lowest entry point, the entry point hoses are the same length (within 25 mm [1.0 in.]), and the entry points are evenly spaced (within 10 % of average spacing).

NOTE 1—Using separate flow meters and flow regulators attached to each entry point allows adjustment of the spacing, height, and flow rates at the entry points based on the tributary area of the wall represented by each entry point. When using a manifold attached to a single flow meter and flow regulator, the spacing, height, and flow rates at each entry point supplied by the manifold must be approximately equal. To ensure that the flow rates from the entry point hoses are within the specified tolerance, the heights of the entry points above the flow meter need to be approximately equal, the lowest entry point must exceed the minimum height above the distribution manifold, and the length of each hose need to be approximately equal. Conformance to the specified tolerance is verified during calibration.

6.1.3 *Flow Regulator*—a valve, either integral with the flow meters or separate, to control the rate of water flow.

6.1.4 *Entry Point Hoses*—hoses attached directly to the flow meter or to a distribution manifold for the purpose of supplying water into the masonry wall drainage system. The diameter of these hoses shall be large enough to ensure that the exterior face of the water flow shall extend no farther than 6 mm [0.25 in.] horizontally beyond the end of the hose at a distance of 500 mm [20 in.] below the end of the hose (Fig. 3).

NOTE 2—High velocity water leaving small diameter hoses may cause water to project beyond the interior face of the exterior wythe. This requirement is intended to ensure that water will flow down the interior surface of the exterior wythe.

6.1.5 *Distribution Manifold*—a series of pipes, tees, elbows, machined distribution block, and other plumbing connections used to distribute water from the water source to each of the water entry points.

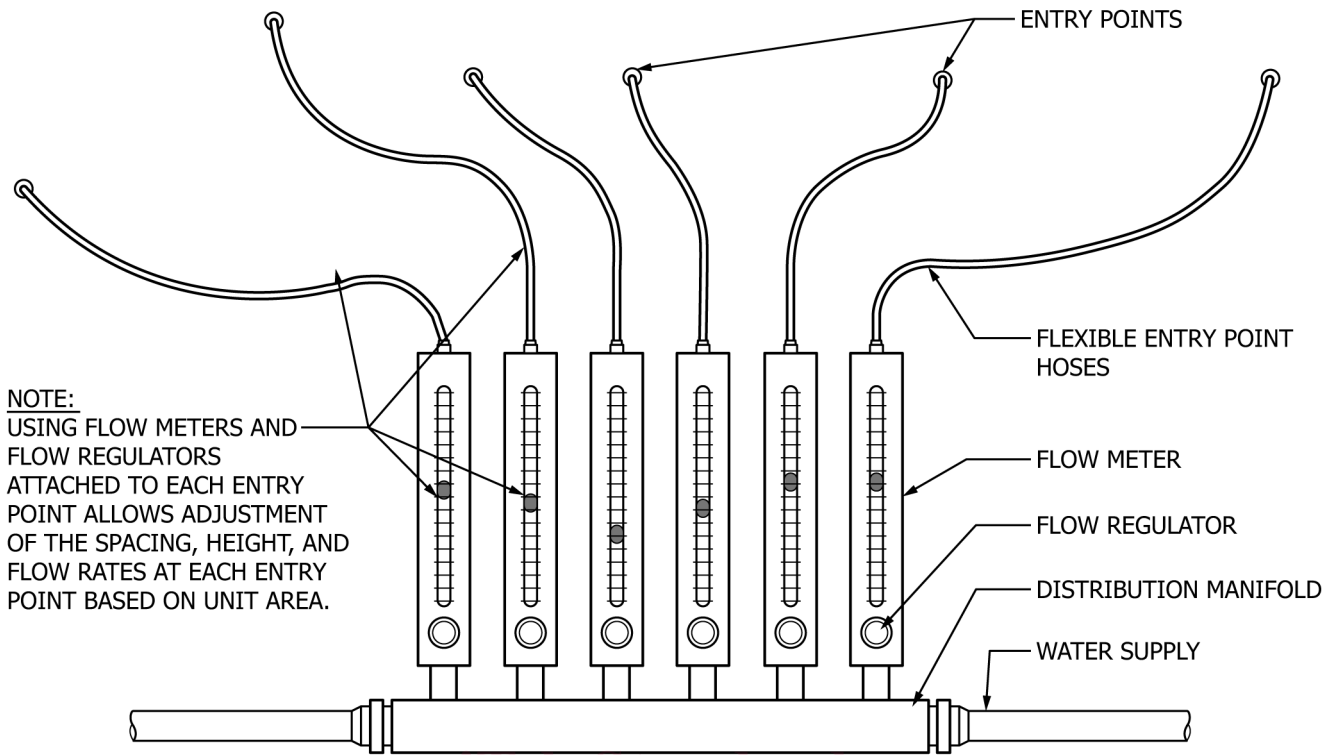

FIG. 1 Flow Meter Connected to Each Entry Point (Type 1)

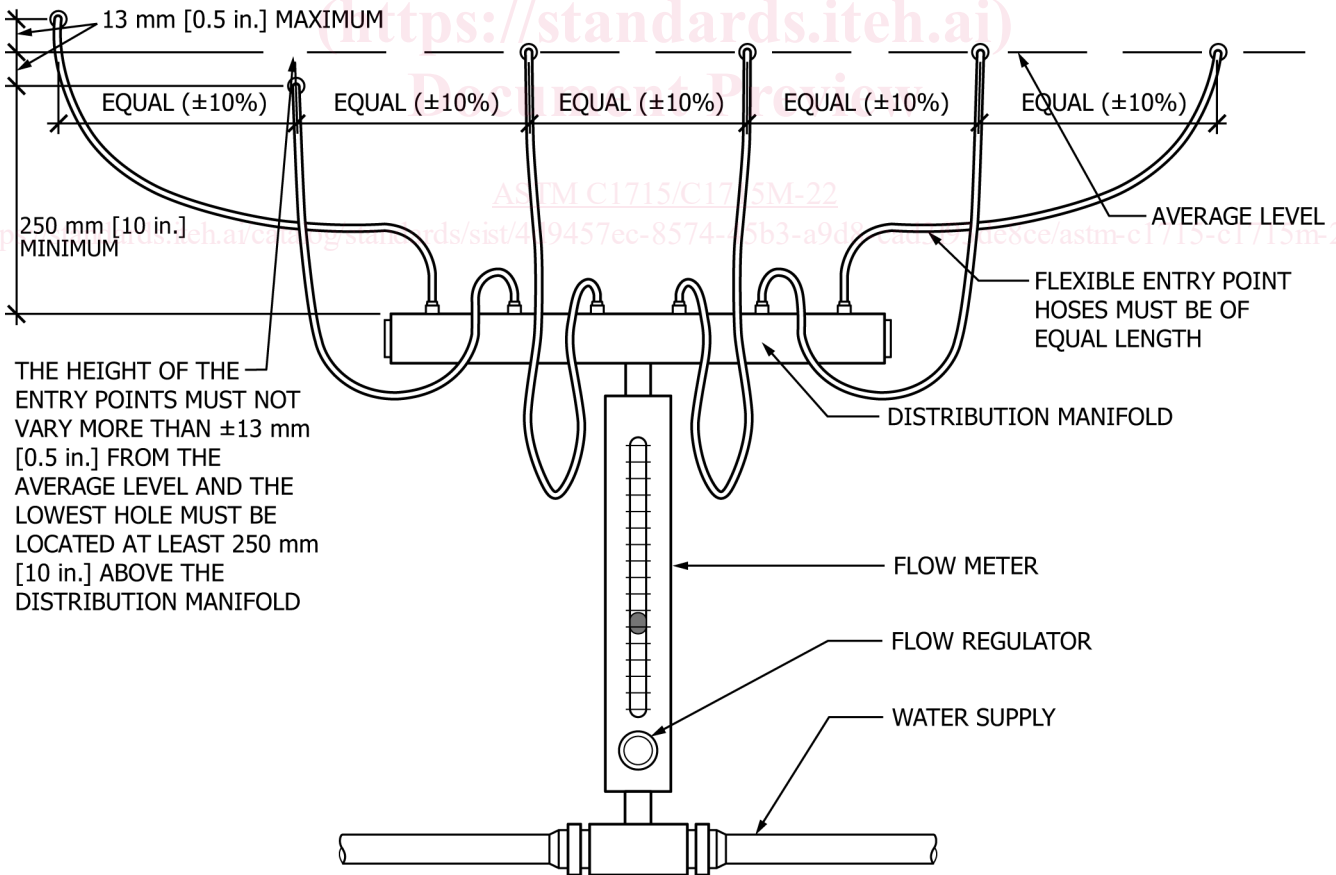
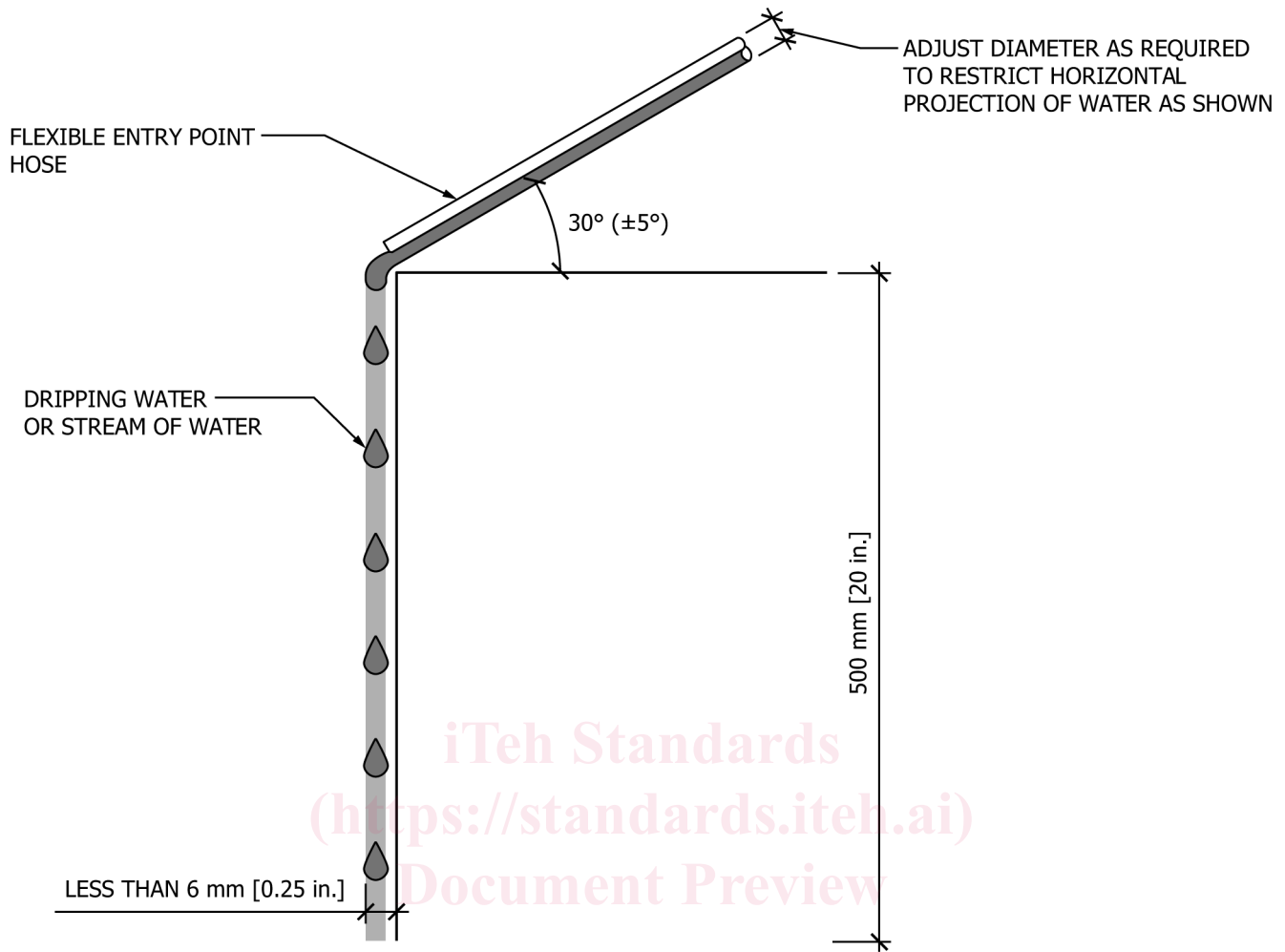

FIG. 2 Flow Meter Connected to Multiple Entry Points (Type 2)



ASTM FIG. 3 Entry Point Hose – 22

<https://standards.iteh.ai/catalog/standards/sist/4d9457ec-8574-45b3-a9d8-cad3f93de8ce/astm-c1715-c1715m-22>

6.1.6 *Graduated Cylinder*—a clear plastic or glass cylinder which is sealed at one end and contains graduations to measure quantities of water with an accuracy of 1 mL [0.034 oz].

6.1.7 *Entry Point*—a hole drilled through a mortar head joint in the exterior wythe of masonry through which water is directed into the drainage zone during the test. Drill entry point holes at a $30 \pm 5^\circ$ angle downward (Fig. 4).

NOTE 3—The 30° downward angle is intended to prevent water from flowing back to the exterior through the entry points during the test.

7. Calibration

7.1 Verify the ability of the test apparatus to meet the applicable requirements by setting up and testing the apparatus in a laboratory. Perform the calibration after initial fabrication and if any change has been made or damage has occurred to the test apparatus. Verify three test levels during each calibration: the highest flow rate at which the apparatus is designed to operate, the lowest flow rate at which the apparatus is designed to operate, and the midpoint between these two test flow rates.

NOTE 4—To ensure that the apparatus is performing correctly in the field, verification of performance is required after the apparatus is set up. See 10.4.

7.2 Position the ends of the water entry hoses at the specified angle listed in 6.1.7 (Fig. 4).

7.3 Check the horizontal projection of water flow from the end of at least one of the hoses to demonstrate that the hose conforms to the requirements of 6.1.4. Locate the measurement device a minimum of 500 mm [20 in.] below the hose. The measurement

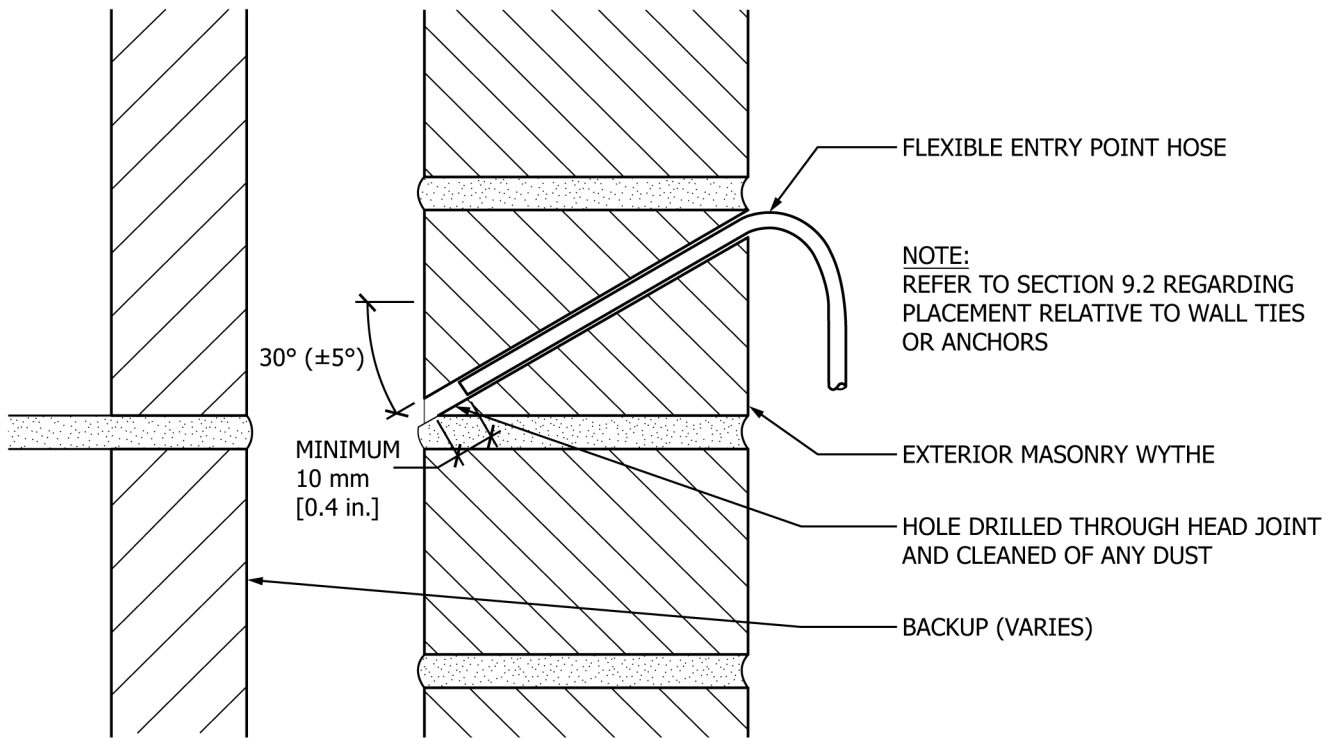

FIG. 4 Entry Point with Hose Inserted

iteh Standards
(<https://standards.iteh.ai>)
Document Preview

device is used to measure the distance from a point directly below the lower edge of the tip of the water entry hose to the outer edge of the water flow within an accuracy of 1 mm [0.04 in.], as shown in Fig. 3. The exterior face of the water flow shall extend no farther than 6 mm [0.25 in.] horizontally beyond the end of the hose. Perform this check at the maximum flow rate at which the water entry hose will be used.

7.4 For an apparatus that uses a flow meter and flow regulator attached to a distribution manifold connected to multiple entry points (Type 2), calibrate the apparatus by setting up the system in a laboratory so that the water entry points are located at the same level (within 2 mm [0.08 in.]) except that one entry point is positioned 13 mm [0.5 in.] above the average level and one entry point is positioned 13 mm [0.5 in.] below the average level. Set the height between the average level of the entry points and the top of the flow meter at the specified minimum level specified in 6.1.2.

NOTE 5—Laboratory studies have been performed with up to six entry points. Experience in the field has shown that distribution manifolds can supply adequate water flow to up to six entry point hoses to meet the calibration requirements of this standard.

7.5 Verify the flow rate at each entry point in either the Type 1 or the Type 2 apparatus using a graduated cylinder by collecting water for a minimum of 30 s after the system has been operating for a minimum of 5 min. The measured flow rate at any entry point hose shall not vary more than 25 % from the test flow rate at each entry point. The total flow rate, determined by adding the flow rates from each of the entry point hoses, shall not vary more than 15 % from the test flow rate at each entry point multiplied by the total number of entry points.

8. Weather Conditions

8.1 Conduct test when the temperatures of the exterior air and of the exterior surface of the masonry are not less than 5°C [40°F].

8.2 Conduct test when the surface of the wall is visibly dry or include in the report the location and the extent or magnitude of moisture present on or within the test wall with photographs, moisture measurements, drawings or notes so that any change in the moisture throughout the test is visible.

9. Preparation of Test Apparatus

9.1 Install entry points on the exterior face of the exterior masonry wythe at a distance above the base of the masonry wall drainage system or element to be tested that is greater than or equal to the spacing of the entry points, but not less than 400 mm [16 in.] (Fig. 5 and Fig. 6).

NOTE 6—The element to be tested may include the flashing or water collection system within the height of the wall; the portion of the wall system where past interior leakage has occurred; a window or other interruption in the drainage zone.

9.2 Locate entry points in head joints in the exterior masonry wall. The spacing between any two entry points shall not to exceed 840 mm [33 in.] on center. Position the first and last entry points within $\frac{1}{3}$ to $\frac{2}{3}$ of the average spacing of entry points from the ends of the length of wall being tested. (See Fig. 5 and Fig. 6.) Locate holes at least one course above the wall tie or anchor or at least 100 mm [4 in.] laterally from the centerline of the wall tie or anchors.

9.3 Test the entire length of wall drainage systems where the flashing or water collection system has a length of less than 3.0 m

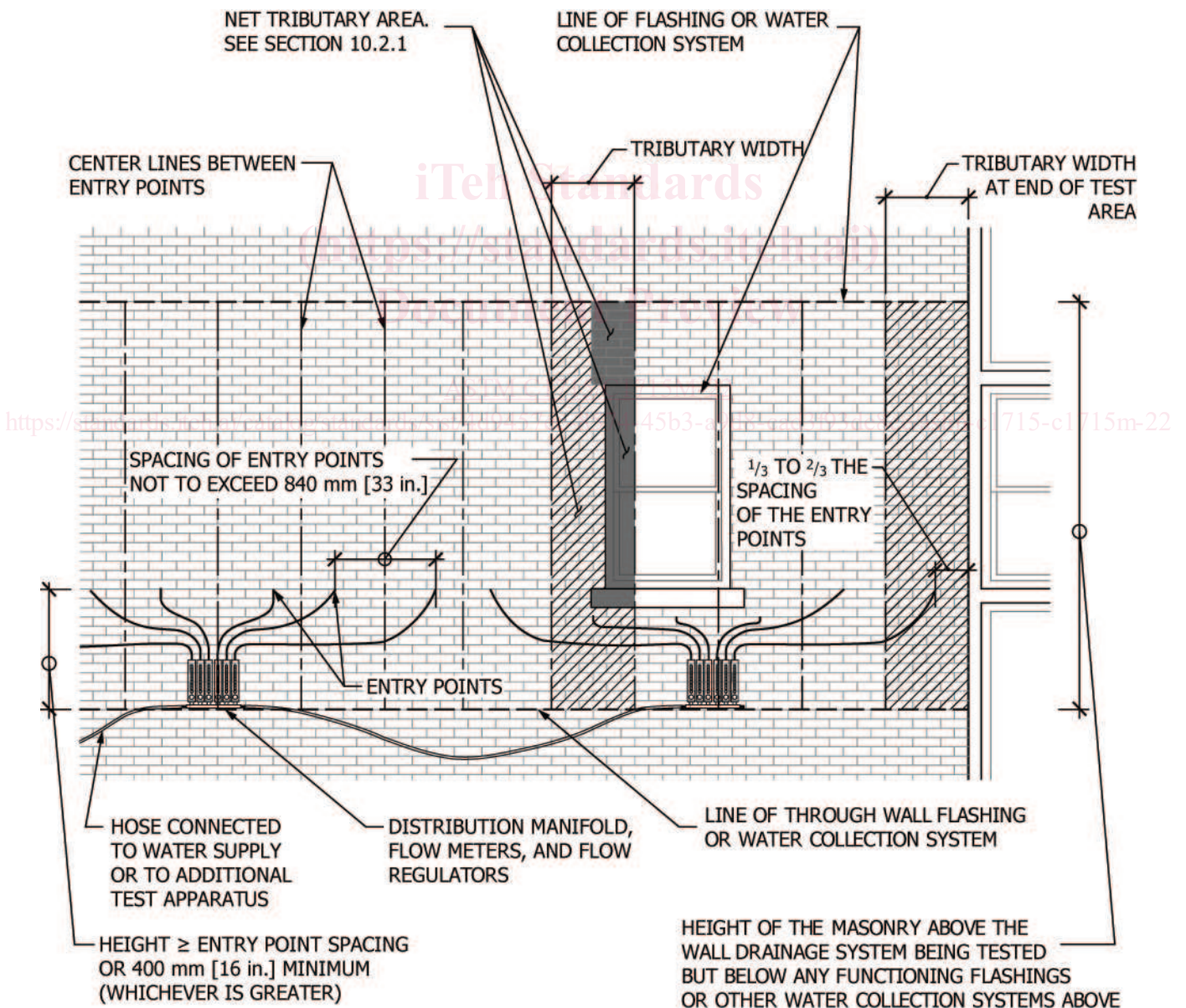

FIG. 5 Elevation of Type 1 System