International Standard



5267/2

INTERNATIONAL ORGANIZATION FOR STANDARDIZATION • МЕЖДУНАРОДНАЯ ОРГАНИЗАЦИЯ ПО СТАНДАРТИЗАЦИИ • ORGANISATION INTERNATIONALE DE NORMALISATION

**Pulps — Determination of drainability —
Part 2 : “Canadian Standard” freeness method**

Pâtes — Détermination de l'égouttabilité — Partie 2 : Méthode «Canadian Standard»

First edition — 1980-11-01

ITeH STANDARD PREVIEW
(standards.iteh.ai)

ISO 5267-2:1980

<https://standards.iteh.ai/catalog/standards/sist/f4f3906-d7ba-403a-946e-007ea2adae1b/iso-5267-2-1980>

UDC 676.1 : 620.168.3

Ref. No. ISO 5267/2-1980 (E)

Descriptors : paper pulps, tests, drainability tests, test equipment, measuring instruments, maintenance, calibrating.

Foreword

ISO (the International Organization for Standardization) is a worldwide federation of national standards institutes (ISO member bodies). The work of developing International Standards is carried out through ISO technical committees. Every member body interested in a subject for which a technical committee has been set up has the right to be represented on that committee. International organizations, governmental and non-governmental, in liaison with ISO, also take part in the work.

Draft International Standards adopted by the technical committees are circulated to the member bodies for approval before their acceptance as International Standards by the ISO Council.

International Standard ISO 5267/2 was developed by Technical Committee ISO/TC 6, *Paper, board and pulps*, and was circulated to the member bodies in January 1978.

It has been approved by the member bodies of the following countries :

Australia	Germany, F. R.	South Africa, Rep. of
Austria	Hungary	Spain
Belgium	India	Sweden
Brazil	Iran	Switzerland
Bulgaria	Ireland	Turkey
Canada	Kenya	United Kingdom
Chile	Mexico	USSR
Egypt, Arab Rep. of	New Zealand	
Finland	Romania	

The member bodies of the following countries expressed disapproval on the document on technical grounds :

Netherlands
USA

Pulps — Determination of drainability — Part 2 : “Canadian Standard” freeness method

0 Introduction

The “Canadian Standard” freeness number depends on the conditions of measurement, particularly the geometric characteristics of the instrument. The only practical means of achieving the required degree of accuracy is by the calibration procedure specified in annex C. The reproducibility of this method is entirely dependent on these arrangements being established within and between countries.

1 Scope

This International Standard specifies a method for determination of the drainability of a pulp suspension in water in terms of the “Canadian Standard” freeness (CSF) number.

The “Canadian Standard” freeness test is designed to provide a measure of the rate at which a dilute suspension of pulp may be dewatered. It has been shown that the drainability is related to the surface conditions and swelling of the fibres, and constitutes a useful index of the amount of mechanical treatment to which the pulp has been subjected.

Results of this test do not necessarily correlate with the drainage behaviour of a pulp material on a commercial paper machine.

A method for the determination of drainability in terms of the Schopper-Riegler number is specified in ISO 5267/1.

2 Field of application

In principle, this method is applicable to all kinds of pulp in aqueous suspension.

NOTE — However, treatments which produce a large proportion of fines may induce an anomalous rise in freeness (false freeness) as a rule at values below 100 CSF number.

3 Reference

ISO 4119, *Pulps — Determination of stock concentration.*

4 Definition

For the purposes of this International Standard, the following definition applies :

“Canadian Standard” freeness number : The volume, expressed in millilitres, of the filtrate collected from the side orifice of the “Canadian Standard” freeness tester.

5 Principle

Drainage through a fibre mat formed during the test on a perforated screen plate of a given volume of pulp in aqueous suspension into a funnel provided with a bottom and a side orifice. Collection of the discharge from the side orifice in a measuring cylinder.

6 Apparatus

Ordinary laboratory apparatus, and

6.1 “Canadian Standard” freeness tester, as described in annex A.

Instructions for maintenance of the apparatus are given in annex B. Details of the Calibration Service for the apparatus are given in annex C. Information concerning authorized laboratories is given in annex D.

6.2 Measuring cylinder, calibrated in millilitres and capable of measuring volume with an error less than 1,0 ml.

7 Preparation of sample

Take a sample of an aqueous suspension of the disintegrated pulp. If the concentration is not known exactly, dilute the suspension to approximately 0,32 % mass/mass using distilled or deionized water (see note 3), and determine the stock concentration in accordance with ISO 4119. Then dilute the suspension to a stock concentration of $0,3 \pm 0,005$ % mass/mass and adjust the temperature to $20,0 \pm 0,5$ °C (see note 4). Throughout the preparation of the sample, take care to avoid the formation of air bubbles in the suspension.

NOTES

1 With time, an aqueous pulp suspension withdrawn from the stock preparation system or laboratory pulp evaluation equipment, can undergo a change in freeness number. To avoid the effect of this reversion phenomenon, pulp suspensions subjected to testing more than 30 min after sampling should first be treated in the disintegration apparatus for 6 000 revolutions of the propeller, at or near the stock concentration specified for the CSF test.

2 The test result is sensitive to the quantity of pulp fines, or "crill", in the suspension. Thickened pulp samples may lose some of this fibre fraction. To avoid such losses during the course of thickening, the filtrate should be recirculated through the pulp pad until the filtrate is clear and the pulp redispersed by disintegration, as described in note 1. This procedure should be used to concentrate dilute pulp suspensions to the stock concentration required for the freeness test.

3 As the drainage of a pulp suspension is affected considerably by dissolved solids and the pH of the water, either distilled or deionized water of equivalent quality should be used throughout the test.

4 Where necessary for climatic reasons, a temperature of 25 ± 5 °C may be applied, provided that this is noted in the test report. In any case, during the test the basic temperature chosen should be kept constant within $\pm 0,5$ °C.

5 In some applications, i.e. process control, larger deviations than 0,005 % for consistency and $\pm 0,5$ °C for temperature may be allowed and corrected with the aid of correction tables given in annexes E and F.

8 Procedure

Clean the funnel and drainage chamber of the "Canadian Standard" freeness apparatus (6.1) thoroughly, and finally rinse with water. Place the drainage chamber in position. Adjust the temperature of the apparatus by rinsing with water at $20,0 \pm 0,5$ °C (see note 4 in clause 7).

Place the receiving vessel (6.2) in position to receive the discharge from the side orifice.

Whilst stirring, transfer $1\ 000 \pm 5$ ml of homogeneous pulp suspension to a clean measuring cylinder.

Close the bottom of the chamber of the freeness tester and open the top lid and the air-cock. Mix the sample by closing the top of the cylinder with the hand and invert the cylinder 180° three times. Avoid introducing air into the stock at this stage.

Pour the stock gently but as rapidly as possible into the chamber. At the end of the pouring, the stock should be motionless in the chamber. Close the top lid and the air-cock and open the bottom lid. Allow 5 s to elapse from the time of pouring the stock, then open the air-cock to start the flow.

When the discharge from the side orifice has stopped, read the volume of this discharge to the nearest 1 ml for values below 100 ml, to the nearest 2 ml for values between 100 ml and 250 ml, and to the nearest 5 ml for values exceeding 250 ml.

9 Expression of results

Carry out two determinations on each sample. Report the mean of two determinations as the "Canadian Standard" freeness (CSF) number. Duplicate determinations differing by more than ± 2 % from their mean value shall be repeated.

10 Test report

The test report shall give the following particulars :

- a) the reference to this International Standard;
- b) all indications necessary for complete identification of the sample;
- c) the test temperature;
- d) the results, expressed in "Canadian Standard" freeness number;
- e) any unusual features observed in the course of the test;
- f) any operations not specified in this International Standard or in the International Standard to which reference is made or regarded as optional, which might have affected the results.

Annex A

The "Canadian Standard" freeness tester

A.0 The "Canadian Standard" freeness tester (see figure 1) comprises a drainage chamber and a rate-measuring funnel, mounted on a suitable support. The rate-measuring funnel shown in figure 1, represents a modified design, adopted by the Canadian Pulp and Paper Association Technical Section as a standard in 1964.

The dimensional and flow specifications given below are those required for the modified instrument to provide freeness results which are in complete agreement with those obtained from the original CS-freeness tester design. Test equipment made to the original design (without the centred side orifice or volume-adjusting plug) may require adjustment to somewhat different values for calibration, and these values should be stated by the manufacturer. Where careful calibration procedures are followed, CS-freeness results, from either tester design, can be made to agree within the limits prescribed in clause A.4.

A.1 The chamber is a metal cylinder whose bottom is closed by a perforated screen plate and lid, hinged on one side of the cylinder and latched at the other. The lid shall be so fitted that not more than 5 ml of water will flow on opening of the bottom cover at the start of the test.

The upper end of this cylinder is closed by a similar lid, attached to the shelf bracket in which the cylinder is held when in use. The hinge and latching mechanisms are so designed that they provide an airtight closure by means of a rubber gasket on the inside of the lid. An air-cock is inserted in the centre of the upper lid for the admission of air into the cylinder at the start of the test.

The cylinder has an internal diameter of 101,5 mm with an internal height of 127,0 mm (from the upper surface of the screen plate to the rim). The diameter is a critical dimension. These dimensions provide a capacity which slightly exceeds 1 000 ml above the screen plate. The air-cock bore is 4,7 mm. This dimension is not critical but should not be subjected to substantial reduction.

A.2 The screen plate is cut into a circular shape, of diameter $111,0 \pm 0,5$ mm, and thickness 0,5 mm, and has perforations of diameter 0,50 mm spaced at 97 per cm^2 . As it has not been possible to standardize the performance of these plates by reference to the dimensions or spacing of the perforations, all plates are calibrated according to the procedure described in Pulp and Paper Research Institute of Canada Standard Testing Procedure Nos. PBA 8 and PBA 3, so that their performance matches that of master plates maintained at the Pulp and Paper Research Institute of Canada, Montreal, or sub-master plates maintained by other centres (see annex C). The plates shall be mounted with the burr side of the perforations downwards.

A.3 The rate-measuring funnel has an open top diameter of 204 mm and an overall length of 277 mm. The main cone has a slope of $29 \pm 5'$ on the inside which flares out into a top cylindrical portion. The bottom (apex) terminates in a carefully machined bottom orifice piece attached to the funnel. The funnel is further provided with a side discharge orifice.

The side discharge orifice consists of a hollow tube, of internal diameter 13 mm, which penetrates the wall of the funnel. This tube is so inserted that the distance between the overflow lip of the tube (inside the funnel) and the bottom of the funnel section is $50,8 \pm 0,7$ mm. This measurement is extremely critical and is set precisely by the manufacturer. Any adjustment of this dimension will exert a significant effect upon the performance of the tester.

The volume in the bottom section of the cone, between the bottom of the funnel and the overflow lip of the side orifice, is adjusted to $23,5 \pm 0,2$ ml by means of the threaded plug. This volume is not critical within the stated limits of the specification, but should not be disturbed.

The bottom orifice (see figure 2) has an overall length of 19,6 mm. The diameter of the orifice venturi is so adjusted during calibration that when it is fed with water at a rate of 725 ± 5 ml/min at $20,0 \pm 0,5$ °C, it will discharge $530,0 \pm 1,0$ ml/min. When assembled on the rate-measuring funnel, this discharge rate should lie within $\pm 1\%$ of 530 ml/min.

When the bottom orifice piece is attached to the apex of the rate-measuring funnel, it shall be concentric, and the two sections shall fit accurately to provide an inside surface which is continuous and uninterrupted.

A detachable protecting spreader cone is supported inside the funnel to prevent the direct entry of splash into the side orifice during the test.

A.4 The screen plates, bottom orifice, side orifice and cone volume are calibrated and adjusted to meet the given specifications. When all of the components are assembled to constitute a complete tester, it may be expected to agree with a master instrument to within $\pm 2\%$ CSF number. Any change in the critical adjustments of any of these components will affect the overall calibration of the assembled tester.

NOTE — Because the modifications incorporated into the new tester design required some dimensional changes in the rate-measuring funnel, certain cone components may not be interchangeable with testers made to the original specifications.

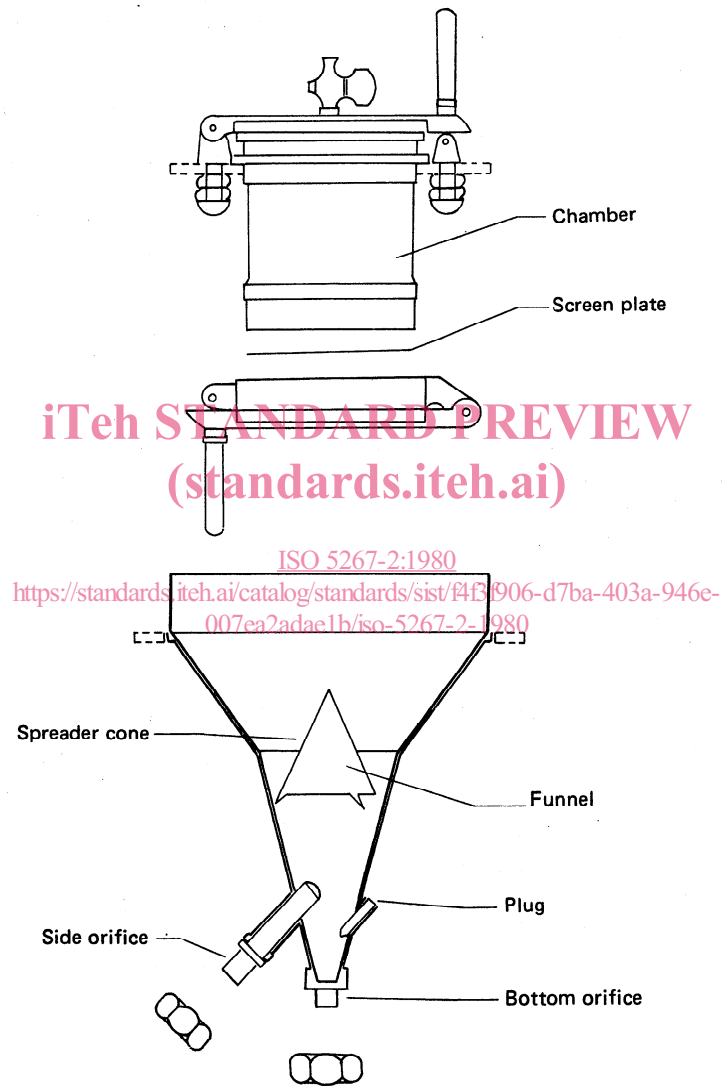

Figure 1 – “Canadian Standard” freeness tester

Dimensions in millimetres

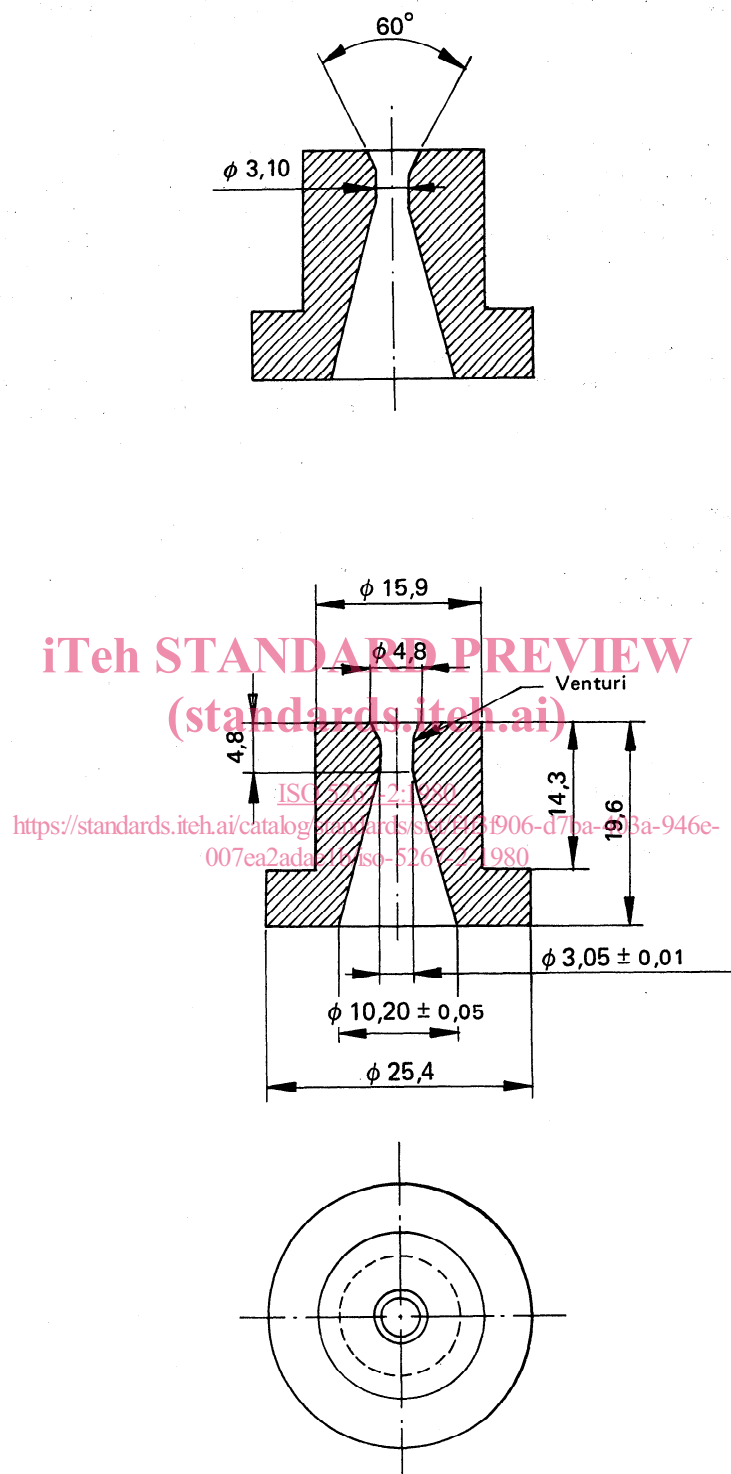

Figure 2 — Bottom orifice

Annex B

Maintenance of the "Canadian Standard" freeness tester

B.1 The instrument shall be mounted in a vibration-free environment, and carefully levelled by a machinist's level placed on the open top of the rate-measuring funnel, in position in the lower bracket. Rotation of the level on the funnel will indicate when the instrument is mounted in a true level position.

B.2 When the funnel is mounted in this way, the remaining components will be aligned correctly, and the instrument is ready for operation.

B.3 The instrument shall at all times be kept clean, free from pulp accumulations, pitch, oil, or grease. After each test, the chamber shall be rinsed out with clean water. It is particularly necessary to ensure that no pulp is retained in the holes of the screen plate. Before any tests are started, the chamber must be well wetted with clean water.

B.4 If the instrument is to remain out of use, it shall be carefully and thoroughly washed so that no pulp will dry on it. Both top and bottom lids shall be left open. Before the instrument is re-used, it shall be well rinsed with clean water.

B.5 The practice of keeping an extra standard screen plate for a reference standard is strongly recommended. The screen plate in current use may then be checked at intervals. With careful use, a screen plate has a long life, but under normal mill conditions it may become dirty with an accumulation of resin which may be removed with an organic solvent or by gentle brushing in a mild detergent, free from carboxymethyl cellulose, phosphates, or bleach, followed by thorough washing with hot water. Except where the materials of construction permit, the instrument and its components should not be cleaned with acid. Bent or damaged screen plates shall be discarded.

B.6 When the screen plate is being replaced, care shall be taken to avoid the application of any pressure that will squeeze the chamber out of round.

B.7 The rate of flow from the bottom of the orifice may be checked at intervals as described in clause A.3. When the flow is less than that specified, the instrument shall be cleaned with an organic solvent or detergent, followed by hot water. More drastic cleaning may destroy the calibration of the bottom orifice. If the flow exceeds that specified, the bottom orifice shall be replaced.

Annex C

Calibration service

C.1 The responsibility for maintaining and operating the "Canadian Standard" freeness tester, which will be recognized as the ISO reference instrument, shall, by agreement of ISO/TC 6, be delegated to the Pulp and Paper Research Institute of Canada (PPRIC) serving as the ISO Standardizing Laboratory for ISO 5267/2. The PPRIC shall maintain a group of identical standard screen plates (hereafter referred to as ISO reference standards of level 1) for the ISO reference instrument.

C.2 The PPRIC shall maintain a group of checking and working standard screen plates of level 2 which differ from the level 1 standards by less than ± 2 CSF number when compared with them under standard drainage conditions. The level 2 standard screen plates shall be used as comparisons in the calibration of screen plates of level 3 for sale and shall be subjected to continual comparison with the level 1 standard.

C.3 Any agency which has upon agreement with ISO/TC 6 been nominated as an authorized laboratory for the calibration of CSF screen plates for sale, shall conform to the following procedure.

C.3.1 The PPRIC shall provide this authorized laboratory initially with five ISO reference standards of level 2. These shall be distinguished using some readily identifiable numbering system. At six-monthly intervals, one of these plates shall be returned to the PPRIC in rotation for replacement by a new, numbered ISO reference standard of level 2. The PPRIC shall maintain records to show the replacement schedule of each authorized laboratory.

C.3.2 The authorized laboratory shall use the ISO reference standards of level 2 obtained from the PPRIC as one checking standard and four working standards to be used in the calibration of screen plates of level 3 for sale. ISO reference standards of level 2 shall not differ from the mean drainage value of level 1 standard by more than ± 2 CSF number.

C.3.3 Screen plates offered for sale as Canadian Screen Plates shall fall within ± 2 CSF number of the mean drainage value of the ISO reference standard of level 2 when compared with a working standard in the standard CSF apparatus.

Each authorized laboratory shall number each of its screen plates offered for sale with an easily identifiable number system and maintain records to indicate the exact date of calibration.

C.3.4 It is recommended that every tenth numbered plate at level 3 be set aside and shipped to the PPRIC for comparison with the PPRIC's standards. A report shall be made to the agency, and the plate returned.

C.3.5 The nominated authorized laboratories shall use, in their calibration procedures, only apparatus which agrees with the specifications of the "Canadian Standard" freeness tester, as described in ISO 5267/2.

NOTE — In case of disagreement at level 3, the standardizing laboratory may request the authorized laboratory to have its apparatus checked by the standardizing laboratory (PPRIC).

iTeh STANDARD PREVIEW
(standards.iteh.ai)

ISO 5267-2:1980

<https://standards.iteh.ai/catalog/standards/sist/11f3906-d7ba-403a-946e-02771e5b1b1b/iso-5267-2-1980>