



Designation: **C635/C635M—17** C635/C635M – 22

Standard Specification for Manufacture, Performance, and Testing of Metal Suspension Systems for Acoustical Tile and Lay-in Panel Ceilings¹

This standard is issued under the fixed designation C635/C635M; the number immediately following the designation indicates the year of original adoption or, in the case of revision, the year of last revision. A number in parentheses indicates the year of last reappraisal. A superscript epsilon (ϵ) indicates an editorial change since the last revision or reappraisal.

1. Scope

1.1 This specification covers metal ceiling suspension systems used primarily to support acoustical tile or acoustical lay-in panels.

1.2 Some suspension systems incorporate locking assembly details that enhance performance by providing some continuity or load transfer capability between adjacent sections of the ceiling grid. The test methods of Test Methods **E3090/E3090M** referenced in this specification do not provide the means for making a complete evaluation of continuous beam systems, nor for assessing the continuity contribution to overall system performance. However, the test methods can be used for evaluating primary structural members in conjunction with secondary members that interlock, as well as with those of noninterlocking type.

1.3 While this specification is applicable to the exterior installation of metal suspension systems, the atmospheric conditions and wind loading require additional design attention to ensure safe implementation. For that reason, a specific review and approval should be solicited from the responsible architect and engineer, or both, for any exterior application of metal suspension systems in the construction of a new building or building modification.

1.4 The values stated in either SI units or inch-pound units are to be regarded separately as standard. The values stated in each system may not be exact equivalents; therefore, each system shall be used independently of the other. Combining values from the two systems may result in non-conformance with the standard.

1.5 The following safety hazards caveat pertains only to the test methods described in this specification. *This standard does not purport to address all of the safety concerns, if any, associated with its use. It is the responsibility of the user of this standard to establish appropriate safety, health, and environmental practices and determine the applicability of regulatory limitations prior to use.*

1.6 *This international standard was developed in accordance with internationally recognized principles on standardization established in the Decision on Principles for the Development of International Standards, Guides and Recommendations issued by the World Trade Organization Technical Barriers to Trade (TBT) Committee.*

2. Referenced Documents

2.1 ASTM Standards:²

[B117 Practice for Operating Salt Spray \(Fog\) Apparatus](#)

[C634 Terminology Relating to Building and Environmental Acoustics](#)

¹ This specification is under the jurisdiction of ASTM Committee **E33** on Building and Environmental Acoustics and is the direct responsibility of Subcommittee **E33.04** on Application of Acoustical Materials and Systems.

Current edition approved ~~Sept. 1, 2017~~ ~~May 15, 2022~~, Published ~~September 2017~~ ~~June 2022~~. Originally approved in 1969. Last previous edition approved in ~~2013~~ ~~2017~~ as ~~C635—13a~~ ~~C635/C635M – 17~~. DOI: ~~10.1520/C0635-C0635M-17~~ ~~10.1520/C0635_C0635M-22~~.

² For referenced ASTM standards, visit the ASTM website, www.astm.org, or contact ASTM Customer Service at service@astm.org. For *Annual Book of ASTM Standards* volume information, refer to the standard's Document Summary page on the ASTM website.



3. Terminology

3.1 ~~Where these terms appear in this specification they shall have the meaning herein~~ Terms used in this standard are defined either in Terminology C634 indicated as follows: or within this standard. The definition of terms explicitly given within this standard take precedence over definitions given in Terminology C634. The definitions within Terminology C634 and this standard take precedence over any other definitions of defined terms found in any other documents, including other documents that may be referenced in this standard.

3.2 ~~Definitions:~~ Definitions of Terms Specific to This Standard:

3.2.1 *backing board, n*—a flat sheet of gypsum board to which acoustical tile is attached using adhesive, screws, staples, or other suitable means (Fig. 1c).

3.2.2 *bow, n*—the maximum component of deviation in the vertical plane of a main runner, cross runner, or wall molding where the centroidal axis of these structural components has been permanently deformed from end to end into the shape of a simple regular curve during the manufacturing process (Fig. 2).

3.2.2.1 Discussion—

The meanings for *bow* and *camber* given here may differ from those applied elsewhere.

3.2.3 *camber, n*—the maximum component of deviation in the horizontal plane of a main runner, cross runner, or wall molding where the centroidal axis of these structural components has been permanently deformed from end to end into the shape of a simple regular curve during the manufacturing process (Fig. 2).

3.2.4 *carrying channel, n*—metal section that supports the entire structural grid network in some forms of mechanical ceiling suspension systems (Fig. 1b).

3.2.4.1 Discussion—

The carrying channels are usually suspended by hanger wires from the existing structure and the main runners are then attached to the channels.

3.2.5 *ceiling suspension system, n*—the entire network or grid of structural components, as defined by the ceiling suspension system manufacturer, that provides support for acoustical ceiling tile, acoustical ceiling panels, lighting fixtures, flexible sprinkler hose fittings and air diffusers.

3.2.6 *cross runner, n*—the secondary or cross beams of a mechanical ceiling suspension system (Fig. 1, a and b). The cross runners usually support only the acoustical tile. In some forms of suspension systems, however, the cross runners also provide support for lighting fixtures, air diffusers, and other cross runners.

3.2.7 *hanger wire, n*—the wire employed to suspend the acoustical ceiling from the existing structure (wood joists, steel bar joists, steel beams, concrete slabs, etc.) (Fig. 1).

3.2.8 *horizontal plane* (of a structural component of a ceiling suspension system), *n*—a plane parallel to the plane of the ceiling which passes through the centroidal axis of the member (Fig. 2).

3.2.9 *interlocking, n*—a ceiling system where the cross runners are connected to the main runner or other cross runners, or both, at intervals controlled by slots, holes, etc. in the main runners.

3.2.10 *main runner, n*—the primary or main beams of the type of ceiling suspension system in which the structural members are mechanically locked together (Fig. 1, a and b). The main runners provide direct support for cross runners, and may support lighting fixtures and air diffusers. In addition, the acoustical tile may also be directly supported by the main runners. In some forms of mechanical ceiling suspension systems, the main runners are supported by hanger wires attached directly to the existing structure. In other forms, the main runners (also referred to as “H” runners, “Z” bars, etc.) are installed perpendicular to carrying channels and are supported by specially designed sheet metal or wire clips attached to the carrying channels.

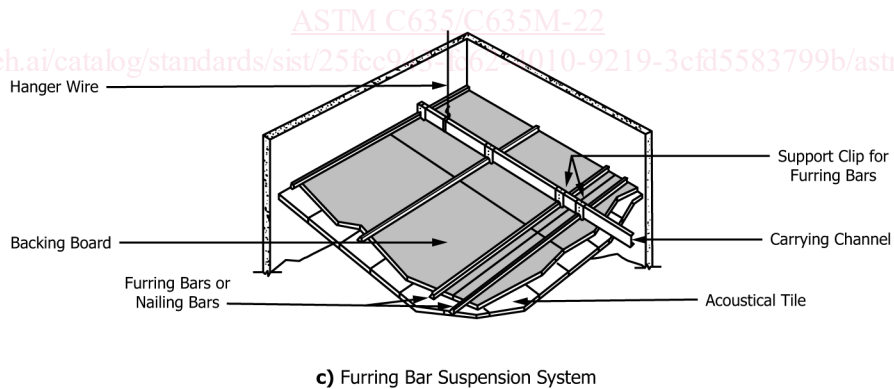
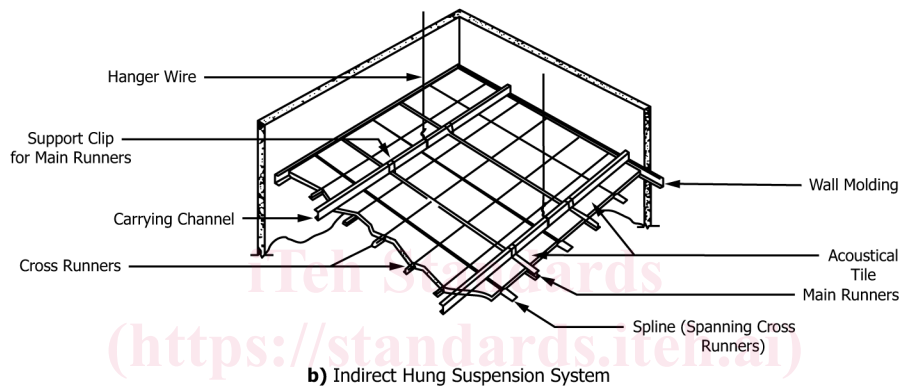
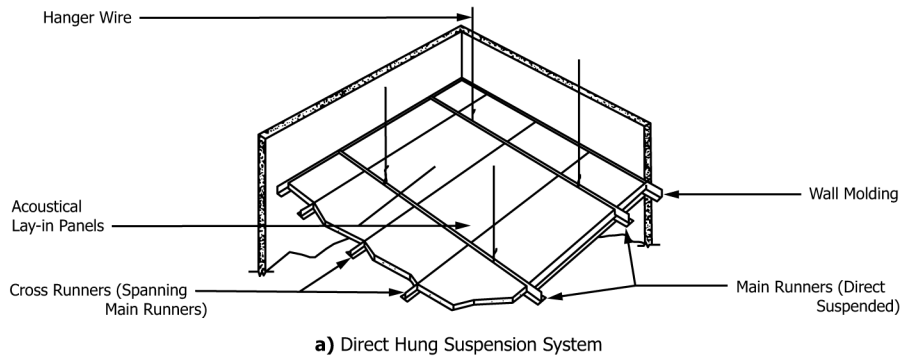

FIG. 1 Three Types of Ceiling Suspension Systems Showing All Components

3.2.11 *nailing bar or furring bar, n*—the continuous sheet metal strips to which a backing board is attached using either nails or screws (Fig. 1c). The nailing bars are installed perpendicular to and supported by the carrying channels.

3.2.12 *non-interlocking, n*—a ceiling system that does not comply with the specifications stated in the definition of interlocking.

3.2.13 *spline, n*—a strip of metal or fiber inserted in the kerfs of adjacent acoustical tile to form a concealed mechanical joint seal (Fig. 1b).

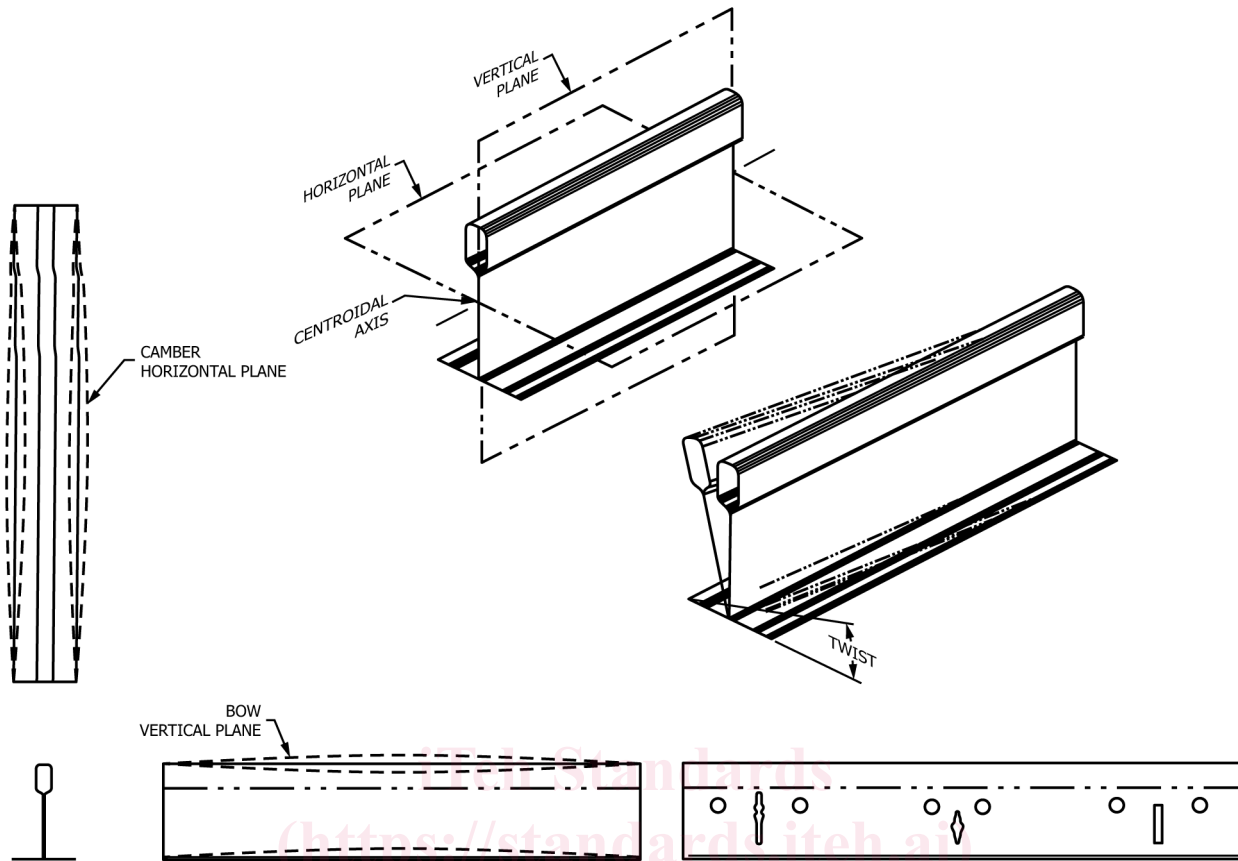

FIG. 2 Diagrams Showing Camber, Bow, and Twist

ASTM Standards
<http://standardsiteb.org>
 Document Preview

ASTM C635/C635M-22

3.2.14 *twist, n*—the angle of rotation measured in a transverse plane between the two end cross sections of a main runner, cross runner, or wall molding which has been permanently deformed during the process of manufacturing (Fig. 2).

3.2.15 *vertical plane* (of a structural component of a ceiling suspension system), *n*—a plane perpendicular to the plane of the ceiling which passes through the centroidal axis of the member (Fig. 2).

3.2.16 *wall molding, n*—the edge angles or channels of a mechanical ceiling suspension system that are attached to a wall (Fig. 1, a and b). The wall molding provides support for the acoustical tile, main runners and cross runners that are located at the periphery of the ceiling.

4. Classification

4.1 The structural performance required from a ceiling suspension system shall be defined by the specifying authority in terms of a suspension system structural classification.

4.1.1 The structural classification of ceiling suspension systems shall be based on the load-carrying capacity of the main runners of the structural network. Load-carrying capacity as used herein is based on the more stringent requirement of esthetic acceptance rather than the less confining prevention of structural failure. The criterion is the arbitrary but widely established limit of deflection to $\frac{1}{360}$ of the span between supports.

4.1.2 The load-carrying capacity shall be the maximum uniformly distributed load (pounds force per linear foot [N/m]) that a simply supported main runner section having a span length of 4 ft, 0 in. [1200 mm] is capable of supporting without the mid-span deflection exceeding 0.133 in. [3.33 mm] or $\frac{1}{360}$ of the 4 ft, 0 in. [1200 mm] span length, as tested in accordance with Test Methods E3090/E3090M.

4.1.3 The structural classification or grade of ceiling suspension systems shall be determined by the capability of main runners or nailing bars to support a uniformly distributed load. These classifications shall be:

4.1.3.1 *Light-Duty Systems*, used where ceiling loads other than acoustical tile or lay-in panels are not anticipated, such as residential and light commercial structures.

4.1.3.2 *Intermediate-Duty Systems*, used where ceiling loads other than acoustical tile or lay-in panels (light fixtures, air diffusers, etc.) are anticipated, such as ordinary commercial structures.

4.1.3.3 *Heavy-Duty Systems*, used where the quantities and weights of ceiling fixtures (lights, air diffusers, etc.) are greater than those for an ordinary commercial structure.

4.1.4 For the purpose of determining the structural classification of main runner members as covered in 4.1.2, their simple-span, minimum load-carrying capabilities, when tested in accordance with the test method described in Test Methods E3090/E3090M, shall be listed as shown in Table 1 and Table 2.

4.2 Cross runners shall be capable of carrying the load specified by the manufacturer without exceeding the maximum allowable deflection equal to $\frac{1}{360}$ of its span.

4.3 The design and definition of the suspension system shall be the responsibility of the manufacturer. Included is selection of appropriate materials, metal thicknesses, dimensions of necessary component section configurations, design of special hanger and assembly devices, and provision for whatever accessory items are needed to ensure satisfactory ceiling performance within the scope of this specification.

4.3.1 System manufacturers may provide supplementary data describing load deflection capabilities of main runners in each classification for spans other than 4 ft [1200 mm].

4.4 Where specialized loading conditions that are outside the scope of this specification exist, the manufacturer should be consulted for his recommendations; and, he may furnish engineering data as required. Specification or design of superstructure anchors or fasteners are not the responsibility of the ceiling system manufacturer unless specified by the ceiling system manufacturer as part of the suspension system.

5. Dimensional Tolerance

5.1 Suspension system *structural members* shall conform to the following tolerance requirements:

5.1.1 Metal Thickness:

5.1.1.1 For *steel systems* the thickness of metal used in main runners, cross runners, wall moldings, splines or nailing bars shall be stated by the suspension system manufacturer in published literature. The thickness in thousandths of an inch [mm] of metal and the allowable thickness variation for the component shall be stated.

TABLE 1 Minimum Load-Carrying Capabilities of Main Runners - Inch/Pound Units

Suspension System	Duty Classification	Applied Load (P)	Equivalent Uniform Load	Allowable Midspan Deflection (d)
		lbf	lbf/ft	
Direct Hung	Light	5.0	5.0	0.133
	Intermediate	12.0	12.0	0.133
	Heavy	16.0	16.0	0.133
Indirect Hung	Light	2.0	2.0	0.133
	Intermediate	3.5	3.5	0.133
	Heavy	8.0	8.0	0.133
Furring Bar	Light	4.5	4.5	0.133
	Intermediate	6.5	6.5	0.133
	Heavy

d=span/360