



Designation: ~~F2638—18~~ F2638 – 22

Standard Test Method for Using Aerosol Filtration for Measuring the Performance of Porous Packaging Materials as a Surrogate Microbial Barrier¹

This standard is issued under the fixed designation F2638; the number immediately following the designation indicates the year of original adoption or, in the case of revision, the year of last revision. A number in parentheses indicates the year of last reapproval. A superscript epsilon (ϵ) indicates an editorial change since the last revision or reapproval.

1. Scope

1.1 This test method measures the aerosol filtration performance of porous packaging materials by creating a defined aerosol of 1.0 μm particles and assessing the filtration efficiency of the material using either single or dual particle counters.

1.2 This test method is applicable to porous materials used to package terminally sterilized medical devices.

1.3 The intent of this test apparatus is to determine the flow rate through a material at which maximum penetration occurs.

1.4 The values stated in SI units are to be regarded as the standard. The values given in parentheses are for information only.

1.5 *This standard does not purport to address all of the safety concerns, if any, associated with its use. It is the responsibility of the user of this standard to establish appropriate safety, health, and environmental practices and determine the applicability of regulatory limitations prior to use.*

1.6 *This international standard was developed in accordance with internationally recognized principles on standardization established in the Decision on Principles for the Development of International Standards, Guides and Recommendations issued by the World Trade Organization Technical Barriers to Trade (TBT) Committee.*

2. Referenced Documents

2.1 *ASTM Standards:*²

[E171/E171M Practice for Conditioning and Testing Flexible Barrier Packaging](#)

[E177 Practice for Use of the Terms Precision and Bias in ASTM Test Methods](#)

[E691 Practice for Conducting an Interlaboratory Study to Determine the Precision of a Test Method](#)

2.2 *ISO Standard:*³

[ISO 5636-3 Paper and Board—Determination of Air Permeance \(Medium Range\)—Part 3: Bendtsen Method](#)

3. Terminology

3.1 *Definitions:*

¹ This test method is under the jurisdiction of ASTM Committee F02 on Primary Barrier Packaging and is the direct responsibility of Subcommittee F02.15 on Chemical/Safety Properties.

Current edition approved Sept. 1, 2018; May 1, 2022. Published September 2018; June 2022. Originally approved in 2007. Last previous edition approved in 2012 as F2638—12; F2638 – 18, ^{ε1}. DOI: 10.1520/F2638-18; 10.1520/F2638-22.

² For referenced ASTM standards, visit the ASTM website, www.astm.org, or contact ASTM Customer Service at service@astm.org. For *Annual Book of ASTM Standards* volume information, refer to the standard's Document Summary page on the ASTM website.

³ Available from American National Standards Institute (ANSI), 25 W. 43rd St., 4th Floor, New York, NY 10036, <http://www.ansi.org>.

3.1.1 *challenge aerosol*—a sufficient quantity of aerosolized 1.0 μm particles that enable effective particle counting in the filtrate aerosol.

3.1.2 *filtrate aerosol*—particles that remain aerosolized after passage through the test specimen.

3.1.3 *maximum penetration*—the highest percent concentration of particles in the filtrate aerosol when a specimen is tested over a range of pressure differentials or air flow rates.

3.2 Abbreviations and Symbols:

| Symbol | Unit | Description |
|----------|---------------------|--|
| C_S | n | Average particle count of the challenge aerosol when using a single particle counter (Method A). |
| C_F | n | Average particle count of the filtrate aerosol. |
| C_C | n | Average particle count of the challenge aerosol. |
| C_{LR} | N | Average particle count of the filtrate aerosol prior to correction for dilution. |
| R | % | Percentage of particles from the challenge aerosol that remain in the filtrate aerosol. |
| R_M | % | The calculated maximum of R . |
| P_1 | cm WC | Pressure differential across a test specimen due to the air flow required by the particle counter. |
| P | cm WC | Pressure differential across a test specimen. |
| F | L/m/cm ² | Air flow rate through the test specimen. |
| F_1 | L/m/cm ² | Air flow rate required by the particle counter when measuring the filtrate aerosol. |
| F_M | L/m/cm ² | Air flow rate at which maximum penetration occurs. |

4. Safety

4.1 The waste and the vacuum venturi vents for the test equipment described in this test method emit an aerosol of polystyrene particles and salt residues. These aerosols should be exhausted from any enclosed environment or collected and filtered to remove all particles.

5. Summary of Test Method

5.1 A porous packaging material test specimen is placed in a sample holder in such a way as to create a filter between the challenge and filtrate aerosols. On the challenge side of the sample holder, an aerosol of particles is presented to the surface of the test specimen. An air flow is generated through the test specimen. A laser particle counter is used to monitor the particle concentrations in the challenge and filtrate aerosols. Particle concentrations will be measured over a range of flow rates in order to measure the percent penetration over the range of flow rates and determine the point of maximum penetration.

5.2 This test uses an aerosol of polystyrene latex particles (PSL) with a geometric mean particle diameter of 1.0 μm and a standard deviation of less than 0.05 μm .

5.2.1 A single particle counter may be used to sequentially measure the challenge and filtrate aerosols or two particle counters may be used to measure them continuously. When using a single particle counter the challenge and filtrate aerosols will be sequentially measured for each test flow rate. The filtrate aerosol concentration is reported as the average concentration of the filtrate aerosol over a time period of 45 to 60 s, beginning no sooner than 1 min from the start of the filtrate aerosol measurement. The challenge aerosol concentration is reported as the average concentration of the challenge aerosol over a time period of not less than 45 s, beginning no sooner than 1 min from the start of the challenge measurement. Challenge concentrations measured immediately before and after each filtrate concentration measurement are averaged to determine the challenge concentration for a given flow rate.

5.2.2 When using two particle counters, the challenge and filtrate aerosols are counted continuously by dedicated particle counters. The challenge and filtrate aerosol concentrations are reported as the average concentration of the challenge or filtrate aerosol over a time period of not less than 45 s, beginning no sooner than 1 min after a change in flow rate.

5.3 At the pressures used in this test, pressure differential across the sample and flow rate through the material are directly

proportional. Pressure will be varied over a range that will ideally have at least two measurements at flow rates that are higher and lower than the flow rate that demonstrates the maximum penetration.

5.4 The reported results are the maximum penetration and the flow rate at which it occurs.

6. Significance and Use

6.1 This test method has been developed as a result of research performed by Air Dispersion Limited (Manchester, UK) and funded by the Barrier Test Consortium Limited. The results of this research have been published in a peer-reviewed journal.⁴ This research demonstrated that testing the barrier performance of porous packaging materials using microorganisms correlates with measuring the filtration efficiency of the materials.

6.2 This test method does not require the use of microbiological method; in addition, the test method can be conducted in a rapid and timely manner.

6.3 When measuring the filtration efficiency of porous packaging materials a typical filtration efficiency curve is determined (see Fig. 1). Since the arc of these curves is dependent upon the characteristics of each individual material, the appropriate way to make comparison among materials is using the parameter that measures maximum penetration through the material.

6.4 The particle filtration method is a quantitative procedure for determining the microbial barrier properties of materials using a challenge of 1.0 µm particles over range of pressure differentials from near zero to approximately 30 cm water column (WC) (2942 Pa). This test method is based upon the research of Tallentire and Sinclair⁴ and uses physical test methodology to allow for a rapid determination of microbial barrier performance.

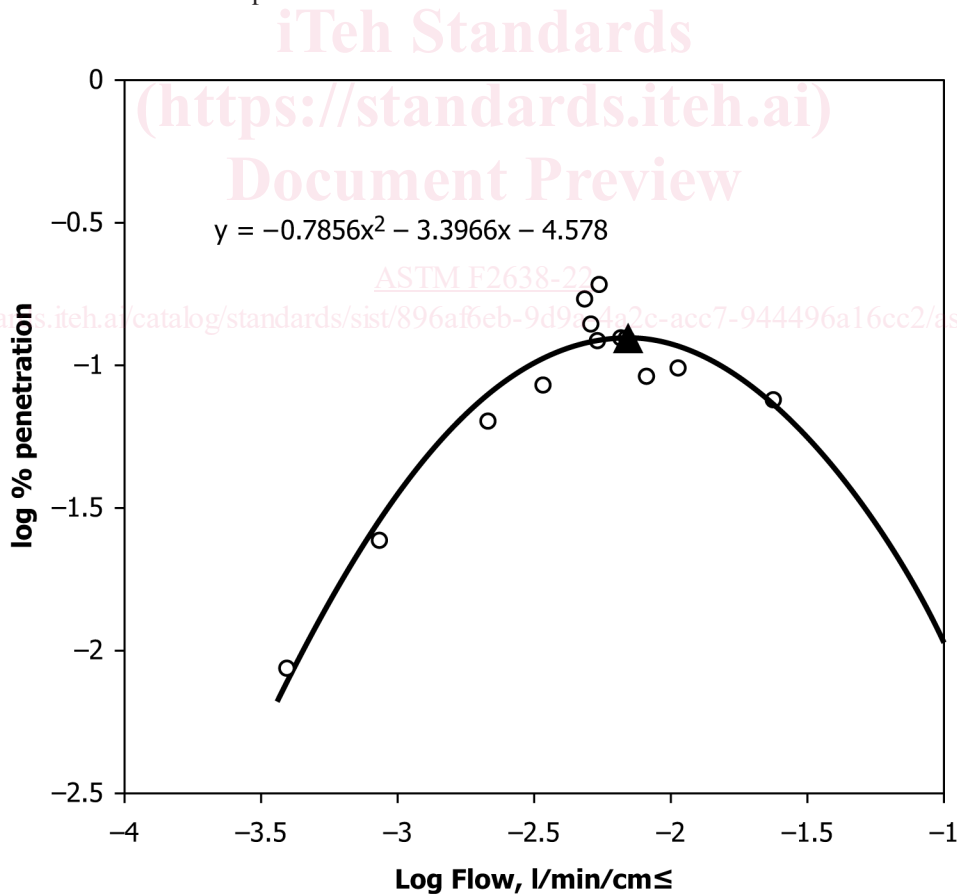

NOTE 1—The point of maximum penetration is indicated by the upward pointing triangle.

FIG. 1 A Typical Curve Showing Penetration as a Function of Flow Rate

⁴ "Definition of a Correlation Between Microbiological and Physical Particulate Barrier Performances for Porous Medical Packaging Materials," *PDA J Pharm Sci Technol*, Vol 56, No. 1, 2002, Jan-Feb, 11-9.

7. Apparatus

7.1 *Test Fixture*—This consists of a base with associated valves, tubing, sample holder and clamps necessary to perform the test. Dimensions of the sample holder (Fig. 2) and schematics of the single particle counter (Fig. 3) and dual particle counter (Fig. 4) are shown. The significant components of the test fixture include:

7.1.1 *Sample Holder*—This consists of two assemblies, which form identical upper and lower manifolds and sample cavities that deliver a uniform flow of the aerosol or sweep air to the periphery of the test specimen while extracting it from the center. To provide consistent sample material placement in the sample holder, a meshed fixture is placed under the sample prior to the closing of the test fixture. Based on the fixture dimensions in Fig. 2; the mesh shall have a diameter of less than 100 mm and greater than 90 mm to fit into the flow cavity. A mesh material of stainless steel T304; eight (8 by 8 per 2.54 cm) mesh T304 stainless steel 0.7112 mm wire diameter; 2.46 mm opening size; 1.4224 mm overall thickness; weave type PSW mill finish or equivalent is recommended. The same fixture should be used, or the fixture noted, when comparing data.

7.1.2 *Normal Flow Range Needle Valve*, 500 μm diameter maximum orifice.

7.1.3 *Low Flow Range Critical Orifice*, 40 μm orifice.

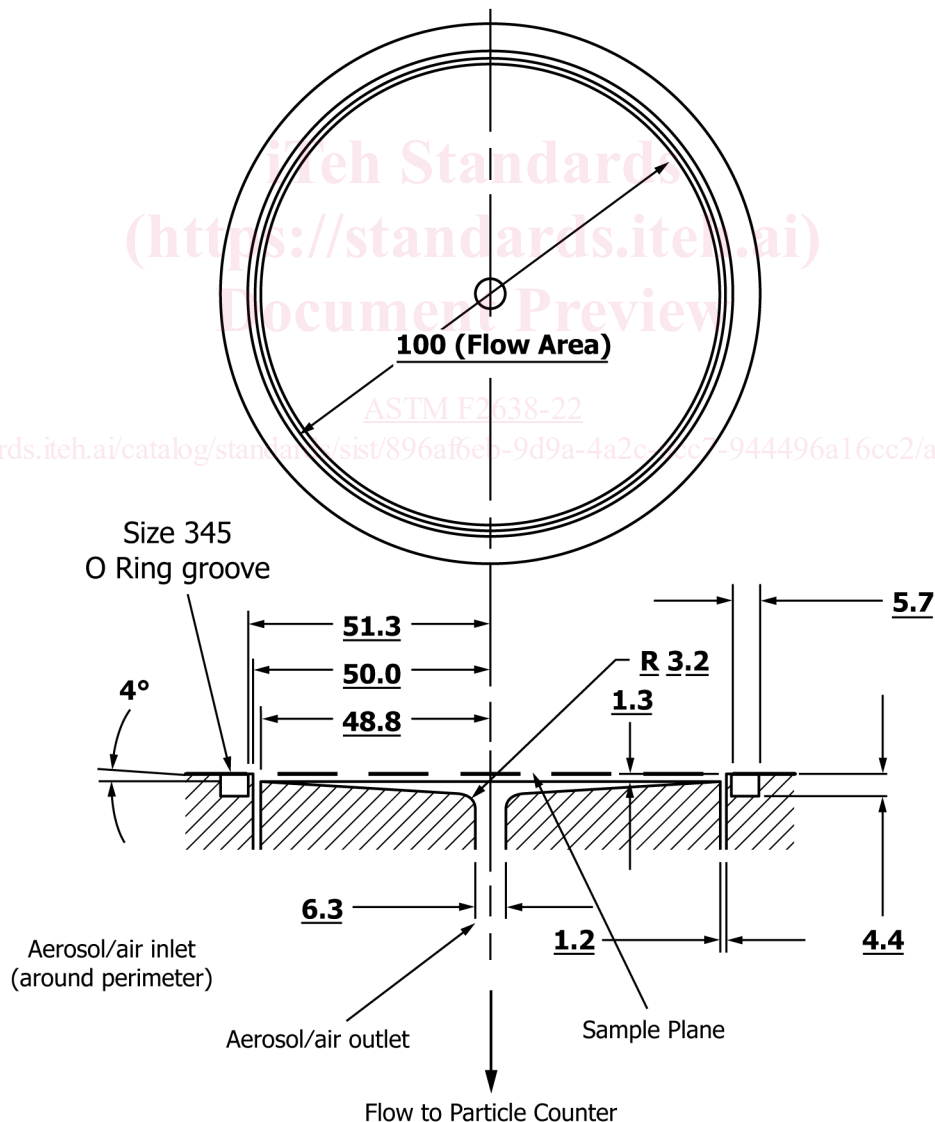

NOTE 1—Dimensions of the cavity in mm. The configuration of the top and bottom cavity is identical.

FIG. 2 Dimensions of the Sample Cavity

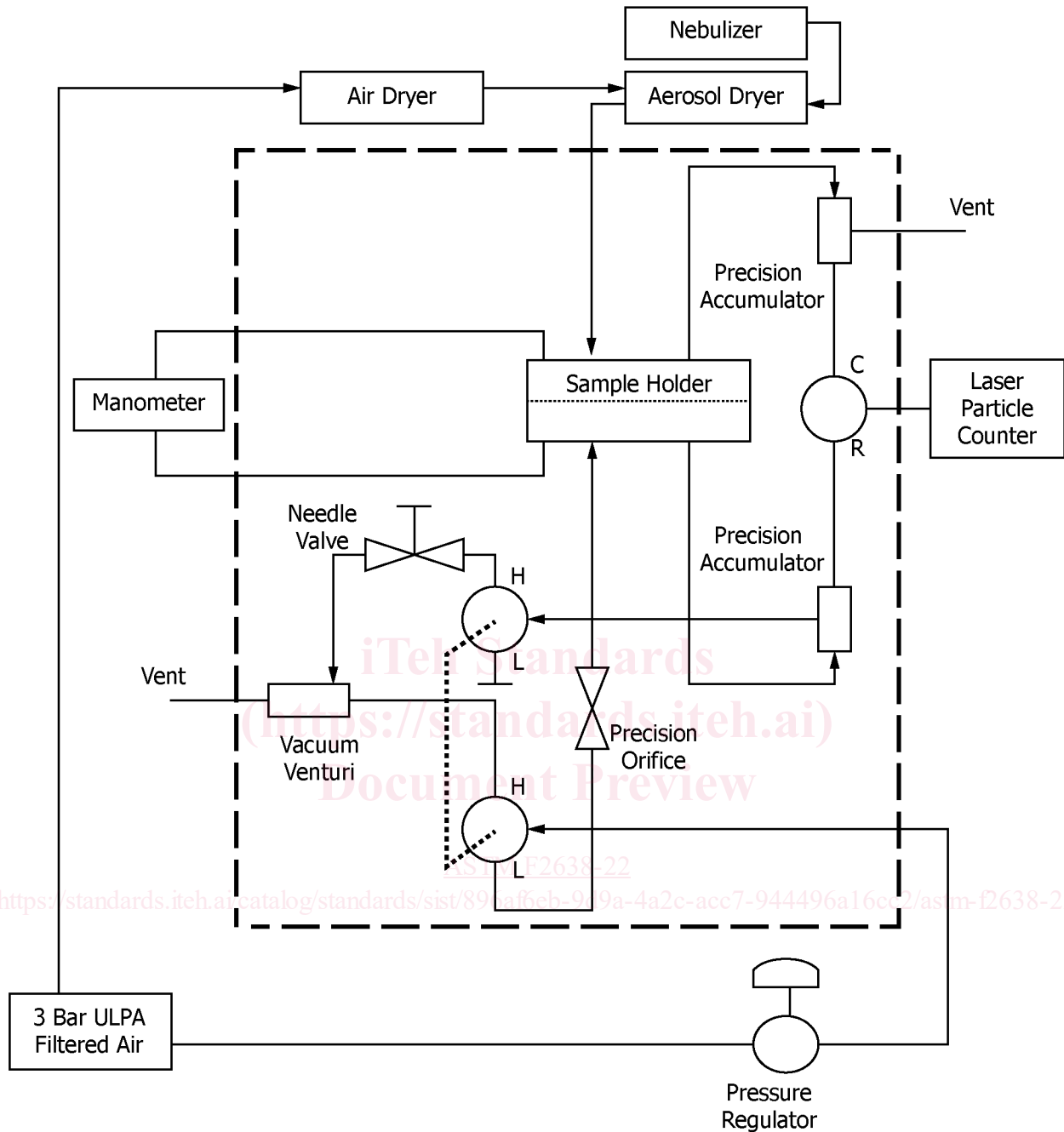

FIG. 3 Equipment Configuration for a Single Particle Counter—Method A

7.2 *Aerosol Generator*—A conventional vertical style medical nebulizer is the preferred aerosol generator for use in a single counter system (Particle Measuring Systems PG100 or equivalent).

NOTE 1—Atomizer style nebulizers are not recommended unless used with a dual particle counter system as they exhibit sudden, unpredictable changes in aerosol concentration.

7.3 *Particle Counter*—The particle counter required for this test method must be capable of distinguishing between the residue from water droplets and the polystyrene latex (PSL) particles. If the particle counter sorts particles by size, it must be determined in which size ranges the PSL particles reside.

7.4 *Data Logging*—The elapsed test time, the pressure differential, the total challenge particles, and/or the total filtrate particles

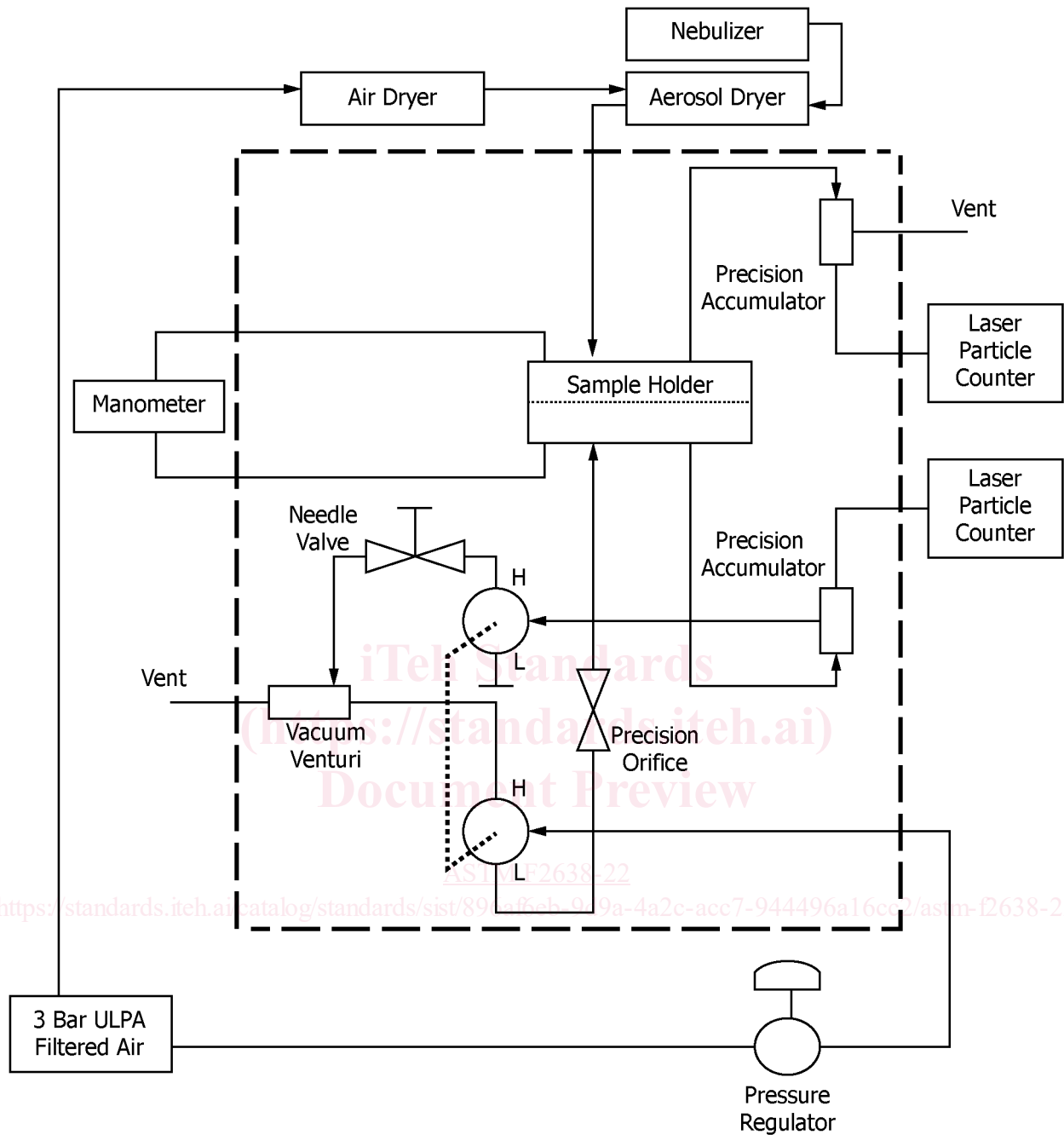

FIG. 4 Equipment Configuration for Dual Particle Counters—Method B

shall be recorded every 6 s. When using some particle counters, the 1.0 μm PSL particles are counted in both the 0.7 to 1.0 μm and the 1.0 to 2.0 μm size ranges. Therefore, both counts shall be recorded and totaled. The bin size difference is due to particle variability.

7.5 *Manometer*—A precision manometer with a minimum range of 0 to 5 cm (0 to 2 in.) water column (WC) (0 to 490.3 Pa) and an accuracy of 0.005 cm (0.002 in.) WC (0.49 Pa) to monitor the pressure difference across the sample.

7.6 *Pressure Regulator*—Precision regulator capable of delivering 1.0 standard litre per minute at pressures up to 3 bar.

7.7 *ULPA Filter*—Required to remove ambient particles.

7.8 *Buna N or Nitrile Rubber SAE Standard AS 568A Size-345 O-rings*—Provide a seal between the challenge and filtrate sides of the test.

7.9 *Precision Accumulator*—To minimize the effect of coincidence in the particle counters due to using high particle concentrations when testing materials with high filtration efficiency, the use of precision accumulators may be needed. A precision accumulator is an inline vessel with a pre-determined volume sufficiently large enough to pull a representative sample of the particle stream. The sample is then diluted using clean air to reduce the resulting concentration down to a level that is within the enumeration range of the particle counters.

8. Materials

8.1 Particle free, dry compressed air.

8.2 Tween 20 or sodium dodecylsulfate (SDS) or equivalent.

8.3 Concentrate suspension of 1 μm PSL particles (Duke Scientific 3K1000, 5100A, and G0100 have all been found satisfactory).

8.4 Purified water sufficiently free of dissolved material. Reference USP Purified/Particle Free Standards.

8.5 Porous packaging material.

8.6 Ultrasonic bath.

9. Apparatus Preparation

9.1 Apparatus should be assembled as seen in Fig. 3 (single particle counter) or Fig. 4 (dual particle counter).

9.2 *Material Preparation:*

9.2.1 *Surfactant Solution:*

9.2.1.1 Prepare a 0.02 % v/v solution of surfactant (Tween 20, SDS, or equivalent) in purified water daily or as needed. The solution should be sonicated before use to ensure the elimination of aggregates of particles.

NOTE 2—It is important to eliminate bubbling in the preparation as the bubbles may interfere with the particle counts. If sonication results in excessive bubbling, mixing by other methods is acceptable.

9.2.1.2 Aerosolize the surfactant solution and determine the particle size distribution of this solution by measuring the challenge aerosol. Ideally there should be no particles over 0.7 μm in diameter detected for the solution only. This does not take into consideration the 1 μm challenge particles. The aim is no more than 2 such particles detected within any 6-s period. Monitor surfactant solution for 1 min.

9.2.1.3 Table 1 is an example of the size distribution of surfactant solution suitable for use, each row being a 6-s counting interval.

9.2.2 *Particle Suspension:*

TABLE 1 Example of Particle Counts Generated from 0.02 % Surfactant in Acceptably Purified Water

| 0.1 μm | 0.2 μm | 0.3 μm | 0.4 μm | 0.5 μm | 0.7 μm | 1.0 μm | 2.0 μm |
|----------------------|----------------------|----------------------|----------------------|----------------------|----------------------|----------------------|----------------------|
| 852 | 176 | 36 | 19 | 4 | 0 | 0 | 0 |
| 879 | 179 | 45 | 15 | 2 | 1 | 0 | 0 |
| 808 | 155 | 38 | 12 | 1 | 0 | 0 | 0 |
| 802 | 176 | 37 | 14 | 2 | 0 | 0 | 0 |
| 828 | 178 | 37 | 14 | 1 | 0 | 0 | 0 |