



Designation: D5906 – 21

Standard Guide for Measuring Horizontal Positioning During Measurements of Surface Water Depths¹

This standard is issued under the fixed designation D5906; the number immediately following the designation indicates the year of original adoption or, in the case of revision, the year of last revision. A number in parentheses indicates the year of last reapproval. A superscript epsilon (ϵ) indicates an editorial change since the last revision or reapproval.

1. Scope

1.1 This guide covers the selection of procedures commonly used to establish a measurement of horizontal position during investigations of surface water bodies that are as follows:

	Sections
Procedure A—Manual Measurement	7 to 12
Procedure B—Optical Measurement	13 to 17
Procedure C—Electronic Measurement	18 to 27

1.1.1 The narrative specifies horizontal positioning terminology and describes manual, optical, and electronic measuring equipment and techniques.

1.2 The references cited contain information that may help in the design of a high quality measurement program.

1.3 The information provided on horizontal positioning is descriptive in nature and not intended to endorse any particular item of manufactured equipment or procedure.

1.4 This guide pertains to determining horizontal position of a depth measurement in quiescent or low velocity flow.

1.5 The values stated in inch-pound units are to be regarded as standard. The values given in parentheses are mathematical conversions to SI units that are provided for information only and are not considered standard.

1.6 *This standard does not purport to address all of the safety concerns, if any, associated with its use. It is the responsibility of the user of this standard to establish appropriate safety, health, and environmental practices and determine the applicability of regulatory limitations prior to use.*

1.7 *This international standard was developed in accordance with internationally recognized principles on standardization established in the Decision on Principles for the Development of International Standards, Guides and Recommendations issued by the World Trade Organization Technical Barriers to Trade (TBT) Committee.*

¹ This guide is under the jurisdiction of ASTM Committee D19 on Water and is the direct responsibility of Subcommittee D19.07 on Sediments, Geomorphology, and Open-Channel Flow.

Current edition approved Nov. 1, 2021. Published June 2022. Originally approved in 1996. Last previous edition approved in 2013 as D5906 – 02 (2013). DOI: 10.1520/D5906-22.

2. Referenced Documents

2.1 ASTM Standards:²

- D1129 Terminology Relating to Water
- D3858 Test Method for Open-Channel Flow Measurement of Water by Velocity-Area Method
- D4410 Terminology for Fluvial Sediment
- D4581 Guide for Measurement of Morphologic Characteristics of Surface Water Bodies (Withdrawn 2013)³
- D5073 Practice for Depth Measurement of Surface Water
- D5173 Guide for On-Line Monitoring of Total Organic Carbon in Water by Oxidation and Detection of Resulting Carbon Dioxide

3. Terminology

3.1 Definitions:

3.1.1 For definitions of terms used in this guide, refer to Terminology D1129.

3.2 Definitions of Terms Specific to This Standard:

3.2.1 *accuracy*—refers to how close a measurement is to the true or actual value. (See Terminology D1129.)

3.2.2 *baseline, n*—the primary reference line for use in measuring azimuth angles and positioning distances.

3.2.3 *continuous wave system, n*—an electronic positioning system in which the signal transmitted between the transmitter and responder stations travels as a wave having constant frequency and amplitude.

3.2.4 *electronic distance measurement (EDM), n*—the measurement of distance using pulsing or phase comparison systems.

3.2.5 *electronic positioning system (EPS), n*—a system that receives two or more EDM to obtain a position.

3.2.6 *global positioning system (GPS), n*—a global positioning system (GPS) is a satellite-based EDM system used in determining Cartesian coordinates (x, y, z) of a position by means of radio signals from NAVSTAR satellites.

² For referenced ASTM standards, visit the ASTM website, www.astm.org, or contact ASTM Customer Service at service@astm.org. For *Annual Book of ASTM Standards* volume information, refer to the standard's Document Summary page on the ASTM website.

³ The last approved version of this historical standard is referenced on www.astm.org.

3.2.7 *horizontal control, n*—a series of connected lines whose azimuths and lengths have been determined by triangulation, trilateration, and traversing.

3.2.8 *line of position (LOP), n*—the locus of points established along a rangeline.

3.2.9 *precision, n*—the agreement among or reproducibility of multiple measurements. (See Terminology **D1129**.)

3.2.10 *pulsed wave system, n*—an electronic positioning system in which the signal from the transmitting station to the reflecting station travels in an electromagnetic wave pulse.

3.2.11 *range, n*—the distance to a point measured by physical, optical, or electronic means.

3.2.12 *range line, n*—an imaginary, straight line extending across a body of water between fixed shore markings.

3.2.13 *range line markers, n*—site poles or other identifiable objects used for positioning alignment on a range line.

3.2.14 *shore markings, n*—any object, natural or artificial, that can be used as a reference for maintaining boat alignment or establishing the boats position as it moves along its course. Examples include range line markers, sight poles, trees, power poles, land surface features, structures, and etc.

3.2.15 *site poles, n*—metal or wood poles used as a sighting rod.

3.2.16 *stadia, n*—telescopic instrument equipment with horizontal hairs and used for measuring the vertical intercept on a graduated vertical rod held vertically and at some distance to and in front of the instrument.

3.2.17 *total station, n*—an electronic surveying instrument which digitally measures and displays horizontal distances and vertical angles to a distant object.

4. Summary of Guide

4.1 This guide includes three general procedures for determining the location or horizontal position in surveying of surface water bodies. The first determines position by a manual procedure. The equipment to perform this procedure may be most readily available and most practical under certain conditions.

4.2 The second determines position by an optical procedure.

4.3 The third determines position by an electronic procedure.

4.4 Horizontal control stations shall be in accordance with Third Order, Class I, Federal Geodetic Control Committee Classification (FGCC) Standards,⁴ with traverses for such controls beginning and ending at existing first- or second-order stations **(1)**.⁵

5. Significance and Use

5.1 This guide is intended to provide instructions for the selection of horizontal positioning equipment under a wide

⁴ Available from National Oceanic and Atmospheric Administration (NOAA), 14th St. and Constitution Ave., NW, Room 6217, Washington, DC 20230, <http://www.noaa.gov>.

⁵ The boldface numbers given in parentheses refer to a list of references at the end of this standard.

range of conditions encountered in measurement of water depth in surface water bodies. These conditions, that include physical conditions at the measuring site, the quality of data required, the availability of appropriate measuring equipment, and the distances over which the measurements are to be made (including cost considerations), that govern the selection process. A step-by-step procedure for obtaining horizontal position is not discussed. This guide is to be used in conjunction with standard guide on measurement of surface water depth (such as standard Practice **D5173**.)

6. Horizontal Positioning Criteria

6.1 The level of accuracy required in horizontal positioning can be defined in three general classes:

6.1.1 Class One pertains to precise positioning demanding a high degree of repeatability.

6.1.2 Class Two is for medium accuracy requirements typical of project condition studies or offshore/river hydraulic investigations, or both.

6.1.3 Class Three is for general reconnaissance investigations requiring only approximate measurements of positions.

6.1.4 **Table 1** provides an estimate of the suitability by Class for the different horizontal positioning discussed within this guide **(2)**.

PROCEDURE A—MANUAL MEASUREMENT

7. Scope

7.1 This procedure explains the measurement of horizontal position using manual techniques and equipment. These include use of tagline positioning techniques and application of shore marks.

7.2 Description of techniques and equipment are general in nature and may need to be modified for use in specific field conditions.

8. Significance and Use

8.1 Prior to the development of optical and electronic positioning equipment, manual equipment and techniques were the only means of measuring horizontal position. These techniques and equipment are still widely used where precise controlled measurements may be required (for example, taut cable method), or where limitations in equipment availability, site conditions and cost considerations prohibit use of more modern equipment.

TABLE 1 Allowable Horizontal Positioning System Error (7)

System	Estimated Positional Accuracy				
	±1 ft RMS	(±1 m) (RMS)	Suitable for Survey Class		
			1	2	3
Visual range intersection	10 to 66	(3 to 20)	No	No	Yes
Sextant angle resection	7 to 30	(2 to 10)	No	Yes	Yes
Transit/theodolite angle intersection	3 to 16	(1 to 5)	Yes	Yes	Yes
Range-azimuth intersection	1.6 to 10	(0.5 to 3)	Yes	Yes	Yes
Tagline high frequency EPS	3 to 13	(1 to 4)	Yes	Yes	Yes

9. Tagline Positioning Techniques

9.1 Tagline positioning techniques makes use of a measuring line having markings at fixed intervals along its length to indicate distance. These can be either a taut cable in which the line is anchored firmly at opposite banks and stretched taut, or a boat mounted cable in which one end of the line is firmly anchored at the bank and the other is attached to a boat with the line fed out as the boat proceeds along its course. Both methods are frequently used low cost positioning techniques. The taut cable is most commonly used for obtaining streamflow measurements and sediment sampling data at non-bridge locations on rivers and streams, but is equally applicable for controlled boat positioning when obtaining river or lake bed profiles for other purposes. In this regard it has proven especially useful for positioning on small lakes or reservoirs, usually where distances involved are less than 1000 ft (305 m), and where sheer walls exist at both ends of the range, or where the presence of dense vegetation along the shoreline precludes use of optical or electronic positioning methods. The boat mounted tagline, in contrast, is much easier to set up and use since only one end of the line is anchored at the shore, but this method can be considerably less accurate due to the increased possibility of misalignment errors.

9.1.1 Taut Cable Method (Manual Procedure):

9.1.1.1 For the taut cable method (see Fig. 1), firmly anchor the ends of the cable on both banks (see 9.1.1.2 for installation) and the line then pulled as taut as possible without pulling the anchors out of the bank. This method of positioning is recognized as accurate for use on streams where the flow velocity does not exceed more than a few feet per second so that the drag induced by the flow, on any boat or other attachment, does not substantially deflect the line. The taut cable method is time consuming when compared to other more modern optical and electronic positioning equipment and techniques; take this into consideration when deciding on which equipment and techniques best apply (3).

9.1.1.2 Installation of the taut cable should be done either in one of two ways: either securely anchor the cable to one bank and the line fed from a boat mounted reel as the boat proceeds across the body of water; or securely anchor the reel to one bank near the water's edge with the loose end towed across. Shore markings can be used for visual alignment, but the

normal procedure is to place a transit or theodolite on line for this purpose. The transmit person, equipped with a two-way radio, relays alignment directions to the boat operator (also equipped with a two-way radio), as the line is transported to the opposite bank. A power or hand winch or hand cranked reel, skid mounted on locally fabricated support assemblies, can be attached to a tree or other firm support on shore and used to take slack out of the line and to minimize sag associated errors in distance. For safety, the reel should come equipped with a spring-loaded pin lock brake assembly. Buoys may be placed at optimum locations along the line to help reduce sag as well as provide an indicator of boat alinement.

9.1.1.3 Taglines for the taut cable method are commonly stainless steel or galvanized 7 by 7 cable, although a fiber line is increasingly being used. The stainless steel lines generally come pre-beaded at 2 ft intervals for the first 50 ft, at 5 ft for the next 100 ft (30 m), and at 10-ft intervals for to the end of the line. Sizes vary in diameter with the length of the cable used. For a length less than 400 ft (122 m), a $\frac{1}{32}$ in. (0.79 mm) diameter line is recommended; for lengths up to 800 ft (244 m), a $\frac{1}{16}$ in. (1.59 mm) diameter is recommended; for greater lengths, the diameter should be at least $\frac{1}{8}$ in. (3.18 mm). The fiber line is normally $\frac{3}{16}$ in. (4.76 mm) diameter, is normally yellow with black markings and generally comes available in any length up to 1000 ft (305 m). It is usually pre-marked with one mark every 10 ft (3 m) and two marks every 100 ft (30 m). To prevent damage when attaching the tagline to a tree, connect the free end of the tagline (the end not connected to a reel), to a 30 ft length of $\frac{3}{32}$ -in. (2.37 mm) diameter cable. One end of this cable should have a harness snap and the other should have a pelican hook. The free end of the tagline should be equipped with a sleeve and thimble, of size matching the tagline diameter (4).

9.1.1.4 Attachments for holding the boat in position at a fixed location along the tag line will vary depending on the specific needs of the data collection effort. Normally the attachment is some form of clamp arrangement. If velocity measurements or sediment sampling is being done along with the water depth measurements, the standard procedure is to equip the boat with a crosspiece (I-beam), normally a little longer than the width of the boat, and set perpendicular to the boat's centerline. The crosspiece is either clamped or bolted in

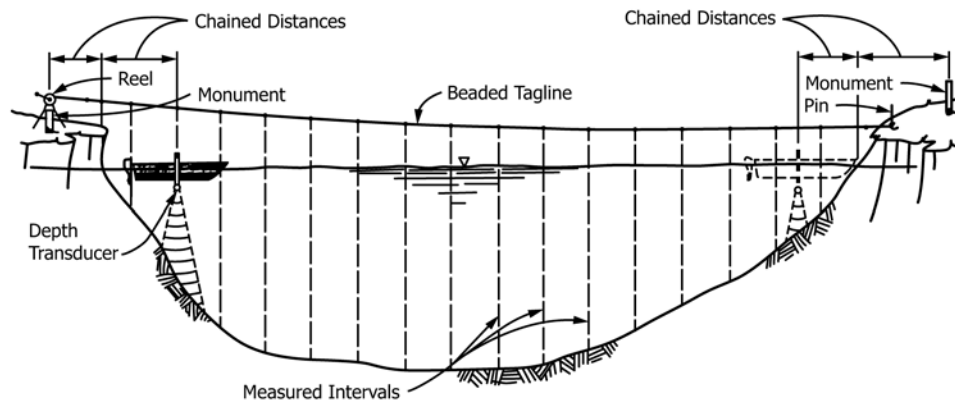

FIG. 1 Taut Cable Method

place and has guide sheaves at each end and a clamp arrangement somewhere along the length of the crosspiece. With the tagline fed through the sheaves, the boat can be held in place or moved along the tagline from station to station. The mid-point clamp permits the boat to be fixed to a one location and not move laterally along the line as measurements are being taken. For safety, fasten a small rope to the clamp to permit quick release in the event of an emergency (4).

9.1.1.5 Position a standby person near the quick-release end of the cable, to release the cable, if there is a possibility of a boat, barge, or other large obstruction colliding with the cable. In addition, a chase boat should also be present in traffic locations, to warn boaters of the cable's presence. For locations where flow velocities are high and boats and obstructions are present upstream, it is recommended that all work boats be kept downstream of the cable.

9.1.1.6 Positions along the line are determined either through the use of a calibrated measuring wheel, or by keeping track of markings attached to the line. Weight, sag, and strength of the line limit its range to less than 1000 ft (305 m). Markings must be clearly visible and easy to understand. The markings are normally crimped brass beads set at 20 ft (6 m) intervals, but this can vary significantly depending on the field application and specific measurement requirements. Attach fluorescent flagging in 4 to 5 ft (1.2 to 1.5 m) lengths at 50 ft (15.2 m) intervals along the length of the cable to assist in ease of distance measurements. Fluorescent flagging provides the best visibility for all types of lighting and is recommended for use in visually marking the cable for safety purposes.

9.1.1.7 Begin measurements by positioning the boat near the bank at a fixed mark on the cable. This initial or starting mark should be determined by chain measurements from a surveyed control point near the water's edge. The boat proceeds from this initial mark along the cable to the opposite shore with a person on board calling out "fix" marks as each marking on the line is reached (5).

9.1.1.8 Maintain alignment of a taut cable within at least 1 to 2 ft (0.3 to 0.6 m) of accuracy.

9.1.2 *Boat Mounted Tagline (Manual Procedure):*

9.1.2.1 This method (see Fig. 2, Fig. 3, and Fig. 4), also referred to as tethered piano-wire method, is similar in principle to the taut cable with the distinction that only one end of the line is anchored at the bank. The opposite end is attached to a reel mounted on the boat and the line is fed out as the boat

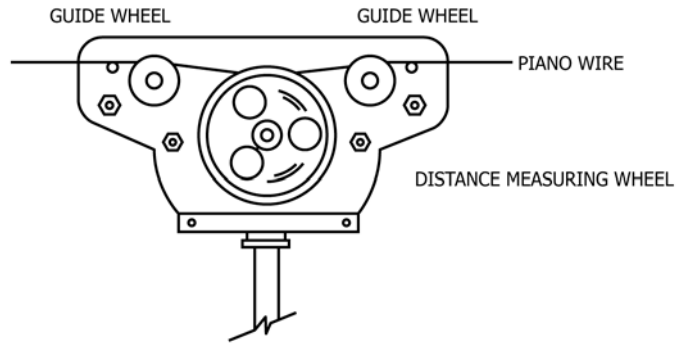

FIG. 3 Calibrated Wheel (Cover Removed)

proceeds along its path. Boat mounted taglines can be used over substantial distances but are not suitable for Class 1 survey use unless the length of the cable is less than 1500 ft (457 m) when stationary measurements are made or less than 1000 ft (305 m) if the boat is moving. Table 2 provides an estimate of positional accuracies for different cable lengths (2). The cable should be constructed of 0.059 in. (0.15 cm) diameter, steel piano wire or steel cable, and have markings attached that permit distance to be read by the length of line released from the reel. The standard guide is to use a reel with a calibrated measuring wheel and mechanical counter that activates as the wheel rotates. Locate the reel in the rear of the boat for safety and position as near as possible to the desired point of measurement (that is, sounding device). If the reel and the point of measurement do not coincide, record the distances between the two and add to the tagline measurements. Boat draft should be less than 1 ft (0.3 m) for accurate measurements in shallow water areas.

9.1.2.2 Establish positions along the boat's path by setting the boat on line and as near to the shore as practical. Then set the counter to zero and pull the loose end of the wire out and fasten it to a pin or other anchoring device driven on-line near the shore. Record distance from the pin to the water's edge on a chart or notebook kept in the boat. With this done, the boat begins to proceed along its designated path. Attach styrofoam floats to the line and dropped overboard at 100 to 300 ft (30 to 91 m) intervals that reduces sag by holding the wire near the surface. Release the line from its starting point as the boat reaches the opposite shore and retrieve it using the motor driven winch aboard the boat (6).

9.1.2.3 Special care should be made to certify that the lateral alignment of the boat is held as the boat proceeds along its path and that the line is held taut. The tagline method maintains alignment through use of visual shore marks. But accuracy can be improved appreciably with a transit or theodolite person relaying alignment directions by a two-way radio.

9.1.2.4 If tagline markings are used in lieu of a measuring wheel, they should be easy to see and understand to avoid errors in determining the readings.

9.2 *Calibrated Wheel (Manual Procedure):*

9.2.1 A 2-ft (0.6 m) diameter calibrated measuring wheel (see Fig. 5) can be used with the taut cable as a replacement for line markings. A counter attached to the wheel registers the revolutions of the wheel as the boat moves along its prescribed

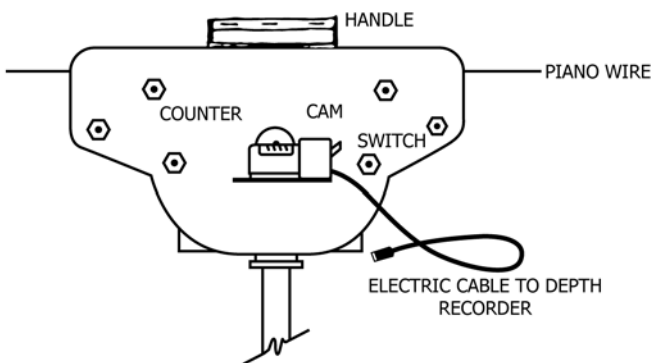

FIG. 2 Calibrated Wheel—Front Cover

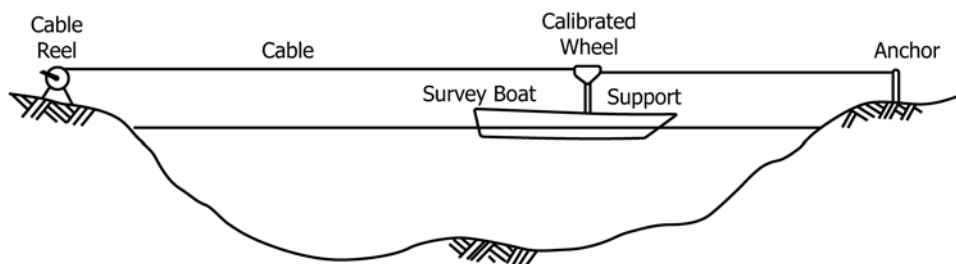

FIG. 4 Calibrated Wheel Method

TABLE 2 Allowable Tagline Positioning Procedures/Systems Criteria (7)

NOTE 1—Tagline distance range limits shown for Class 1 and Class 2 surveys are contingent on the tagline being pulled clear of the water and held taut during measurement. Distances for Class 1 surveys shall be adjusted downward depending on the capabilities of the boat and equipment used.

System	Estimated Positional Accuracy		Suitable for Survey Class		
	±1 ft RMS	±1 m RMS	1	2	3
	Tagline (Boat Stationary)				
<1500 ft from baseline	1 to 3	(0.3 to 1)	Yes	Yes	Yes
>1500 to <3000 ft	3 to 16	(1 to 5)	No	Yes	Yes
>3000 ft from baseline	16 to 164	(5 to 50 +)	No	No	Yes
Tagline (Boat Moving)					
<1000 ft from baseline	3 to 9	(1 to 3)	Yes	Yes	Yes
>1000 to <2000 ft	8 to 20	(3 to 6)	No	Yes	Yes
>2000 from baseline	20 to 164 +	(6 to 50 +)	No	No	Yes
Tagline Calibration Frequency (in months)			1	6	12
Accuracy of Independent Calibration (feet)			0.1	1	5
Accuracy of Independent Calibration (meters)			0.03	0.01	1.52

path. Anchor the piano wire on both banks and hold taut with enough sag to permit the piano wire to encircle the wheel, but provide enough friction to prevent slippage. Repair breaks that might occur in the line through the use of a compressed-sleeve type wire splicer.

9.2.2 The procedure for the calibrated wheel method is the same as that described for the taut cable, except that the calibrated wheel is used in lieu of markings permanently attached to the line. The positioning begins with the boat stationed at a fixed measured point on the line (established by distance measurement from a control station on shore), the counter on the wheel set to zero, and the boat's position relative to this starting position measured as the boat moves along its path.

10. Cable Reels (Manual Procedure)

10.1 Cable reels must be constructed of sturdy material and be equipped with a manual, electrical, or gasoline powered winch, including a clutching and braking assembly. The brake is used both for controlling rotation of the reel as the cable is let out and to serve as a safety feature. For hand operated reels, the crank should be hinged to allow the crank to be disengaged from the shaft while the wire is let out and engaged for reeling in. Various devices are employed to drive a counter to register the amount of cable released from the reel (5).

10.2 The cable for the boat mounted tagline should be made of galvanized, commercially available aircraft cable with 3/32 in. (2.38 mm) outside diameter (O.D.) and seven by seven construction. Some cables may also come with a nylon coating to reduce fraying typical of uncoated steel cables. The coating, however, increases the outside diameter to 1/8 in. (3.18 mm) and reduces the length of cable that can be wound on a reel by about 50 %. Plastic water-ski tow cable of 1/4 in. (6.35 mm) diameter, 1 lb/100 ft weight (0.45 kg/30.5 m), is available from sporting goods stores and may also be used occasionally with good success but is not recommended for use during windy conditions because of the tendency to be deflected. The plastic cable has the advantage of being easily repaired in the field by telescoping one end into the other.

11. Current Meters (Manual Procedure)

11.1 A standard "Price current meter" suspended from a boat, in which the propeller blade rotates because of movement of the boat, can be used to measure the distance the boat has traveled by keeping track of the accumulative revolutions of the meter times a calibration constant for the mounted meter. When coupled with the sonic-sound "fix" switch, the current meter can be used in a semi-automatic operation for recording and documenting positions along the range line.

12. Shore Marks (Manual Procedure)

12.1 Shore marks may be used with taglines, alone in pairs, or with optical and electronic procedures. Their function is to help maintain boat alignment as the boat moves along its prescribed course. The boat operator can visually align the boat's movement on target with the two or more shore marks, or an instrument man on shore can convey instructions by two-way radio as the boat proceeds between shore marks on the opposite bank. A transit works well for stadia positioning since the transit can be used both for alignment and stadia measurements. Shore marks, placed in a perpendicular alignment to the boats path, can serve as an indicator of position and, as such, provide a good, rough measurement of position for reconnaissance surveys.

12.2 Accuracy in use of shore marks depends on ease of visibility and how sharp the delineation is between the two or more objects being used for line of sight. Place the shore marks far enough apart to enable alignment to be clearly distinguishable.

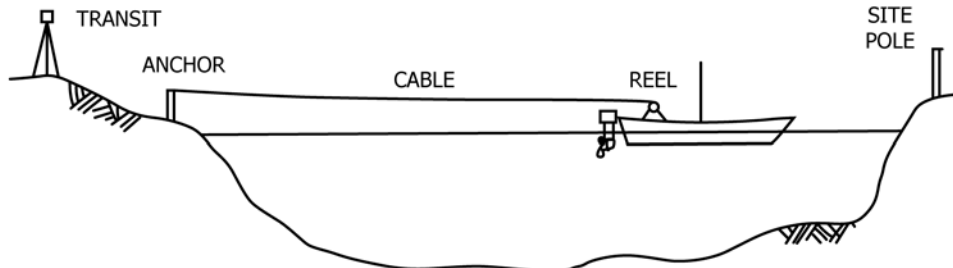

FIG. 5 Tag Line

PROCEDURE B—OPTICAL MEASUREMENT AND ALIGNMENT

13. Scope

13.1 This procedure explains the use of optical equipment in horizontal positioning.

13.2 Equipment includes transits, theodolites, and alidades, along with sextants, or range poles. The techniques applied include stadia positioning, transit intersection, transit-stadia positioning, and sextant positioning.

14. Stadia Measurements (Optical Procedure)

14.1 The stadia method (see Fig. 6) uses transit or alidade standard guides similar to that applied in standard land surveying applications. For boat positioning, however, the stadia board is much larger in size and often has coded markings in lieu of numbers. Fig. 7 illustrates a section of a typical board used by some field offices of the U.S. Army Corps of Engineers. The board must be securely mounted in the sounding boat and positioned as near to the required point of measurement as possible. Distances are normally read at 100 ft (30.5 m) intervals, unless field needs warrant otherwise. The transit operator is stationed on shore at a surveyed control point and conveys alignment and distance instructions to the boat operator through use of two-way radios. Each distance measurement is usually preceded by a “stand-by” message (including an indication of the distance), followed in a few seconds by the signal “fix” as the actual distance is read. The spacing of fix marks can be made either by the transit or sounder operator. If made by the transit operator, the spacing is more uniform and the chance for erroneous readings is reduced. If made by the sounding operator, the operator of the water depth measurement instrument, the spacing can be determined by the change

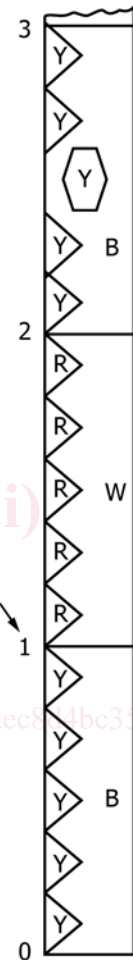

Foot Indicators

Color Code:
 B - Black
 R - Red
 W - White
 Y - Yellow

FIG. 7 Stadia Board

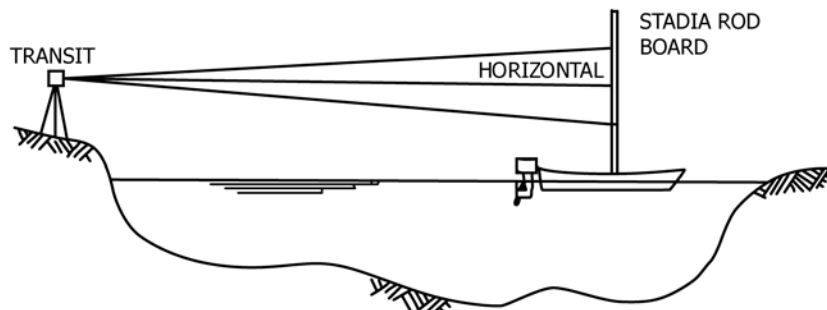

FIG. 6 Stadia Method

in boat speed and the need for distance reading is indicated when abrupt changes in depth are detected.

14.2 The limit for distance measurements using stadia depends on the length of the stadia board and the telescopic power of the transit. This limit should not normally exceed 1000 to 1500 ft (305 to 457 m). Longer distances are possible by stationing an instrument person at each end of the range and overlapping and averaging several stadia readings.

14.3 A stadia board should be at least 15 ft (4.6 m) in length, hinged into two 7½ ft (2.3 m) sections for easy transport, have a triangular cross section with 6 in. (1.5 mm) side widths, and be constructed of aluminum. The markings on the stadia board should be in an alternating pattern of white markings with red points and black markings with yellow points. This enables it to be distinguishable against a variety of backgrounds and more visible at greater distances. In addition the board should be equipped with special marking to signify 250, 500 and 750 ft distances.

14.4 The standard procedure in obtaining stadia measurements is to set the transit on the rangeline alignment, on land, and near the water's edge. The transit should be plumbed over a surveyed control point and be at normal eye level but as near to the water level as possible to avoid the need for excessively long stadia rods. Care must be taken to assure that the stadia rod is firmly mounted in the boat. Stadia readings are best obtained when waves are not present because of the difficulty in obtaining readings in a timely and accurate manner under conditions where the boat is subject to motions of pitch, roll, yaw, and heave. A tape, chain, stadia reading, or other suitable form of measurement will have to be made between the vertical centerline of the transit's position and the stadia rod before the boat can begin to proceed along its course. If possible the boat should proceed at a constant speed. A "fix" signal should be given when the boat has to slow down on reaching the shore with a final reading when the boat reaches the opposite bank.

15. Transit Intersection (Optical Procedure)

15.1 This is a two-transit method (see Fig. 8): one transit is placed on line with the boat's prescribed path and used for alignment instructions and the second is located at some known relative position upstream or downstream to permit the determination of an angular position on the boat as it proceeds on its course. The boat's positions along the path is determined by measuring the straight or baseline distance between the two transit stations, A and C, observing the interior angle formed between this baseline and the boat at Station x_n , then solving trigonometrically for the leg of the triangle represented by the distance between the boat and the transit at Station A. Make position readings at 100-ft (30-m) intervals or as essential to permit an accurate profile of the lake bed surface. The angles may be predetermined to intersect fixed positions along the course. Examples would be 100-ft (30 m) or 200-ft (61 m) spacings. "Fix" marks are transmitted to the boat by two-way radios as the boat reaches each mark.

15.2 The angle of intersection at the boat should be such that a directional error of 1 min in arc from a transit station will not cause the position of the boat to be in error by more than

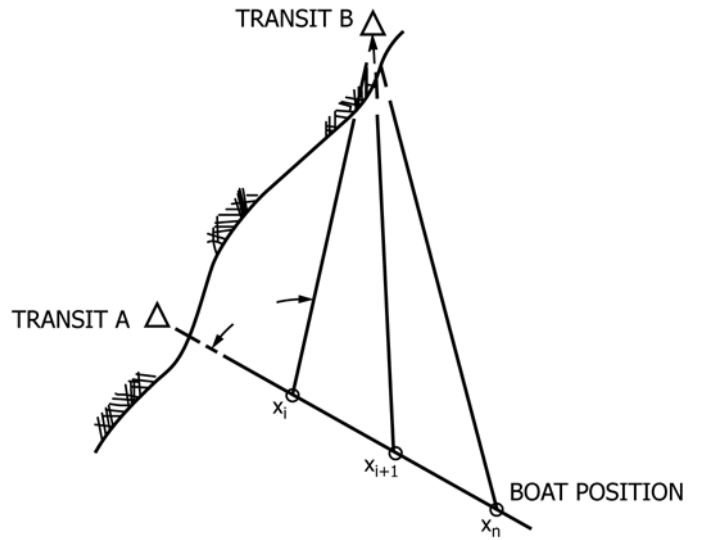

FIG. 8 Transit Intersection

1.0 min at the scale of the maps being used. Angles should be maintained between 30 and 150°. Table 3 provides an estimate of positional error due to azimuth misalignments (7).

16. Triangulation/Intersection Positioning (Optical Procedure)

16.1 The intersecting lines of sight (see Fig. 9) from two or more shore based transit or theodolite stations provide an accurate measurement of boat position, suitable for all three classes of horizontal positioning. Each observation point can be determined graphically, by plotting the angular data, or mathematically, by using the known distance between any two shore stations and the inclosed angles formed by the intersecting lines. Read angles to the nearest 0.01° and make at least two backsight checks when the instruments are initially set up. Make frequent rechecks if the instruments are to be used for several sets of measurements.

16.2 Accuracy of the triangulation/intersection method is strongly dependent on the precision of the instruments, the experience of the operators, the effectiveness of the coordinated positional "fixes" (made by two way radio), and the accuracy of the control point survey. As in intersection methods, the angle formed by the intersecting lines should be between 30 to 150° (3). Measure azimuths to within 30 s of arc (1).

TABLE 3 Positional Error Due to Azimuth Misalignment (7)

Distance, ft (m)	Distance Error per Alignment Procedure	
	Sextant (±20 min), ft (m)	Transit (±2 min), ft (m)
100 (30)	0.6 (0.2)	0.1 (0.0)
500 (152)	3 (0.9)	0.3 (0.1)
1000 (305)	6 (1.8)	0.6 (0.2)
2000 (610)	12 (3.7)	1.2 (0.4)
5000 (1524)	29 (8.8)	2.9 (0.9)
10 000 (3048)	58 (17.7)	6 (1.8)