



Designation: C1861 – 22

Standard Specification for Lathing and Furring Accessories, and Fasteners, for Interior and Exterior Portland Cement-Based Plaster¹

This standard is issued under the fixed designation C1861; the number immediately following the designation indicates the year of original adoption or, in the case of revision, the year of last revision. A number in parentheses indicates the year of last reapproval. A superscript epsilon (ϵ) indicates an editorial change since the last revision or reapproval.

1. Scope*

1.1 This specification contains the minimum requirements for lathing and furring accessories, and fasteners, as components of interior and exterior portland cement-based plaster assemblies, used to facilitate lathing and furring installation (Specifications C1063, C1787), cement plaster application (Specification C926), and functionality of the completed stucco cladding assembly.

1.2 The values stated in inch-pound units are to be regarded as standard. The values given in parentheses are mathematical conversions to SI units that are provided for information only and are not considered standard.

1.3 *This international standard was developed in accordance with internationally recognized principles on standardization established in the Decision on Principles for the Development of International Standards, Guides and Recommendations issued by the World Trade Organization Technical Barriers to Trade (TBT) Committee.*

2. Referenced Documents

2.1 ASTM Standards:²

- A240/A240M Specification for Chromium and Chromium-Nickel Stainless Steel Plate, Sheet, and Strip for Pressure Vessels and for General Applications
- A580/A580M Specification for Stainless Steel Wire
- A641/A641M Specification for Zinc-Coated (Galvanized) Carbon Steel Wire
- A653/A653M Specification for Steel Sheet, Zinc-Coated (Galvanized) or Zinc-Iron Alloy-Coated (Galvannealed) by the Hot-Dip Process
- B69 Specification for Rolled Zinc

- B221 Specification for Aluminum and Aluminum-Alloy Extruded Bars, Rods, Wire, Profiles, and Tubes
- C926 Specification for Application of Portland Cement-Based Plaster
- C954 Specification for Steel Drill Screws for the Application of Gypsum Panel Products or Metal Plaster Bases to Steel Studs from 0.033 in. (0.84 mm) to 0.112 in. (2.84 mm) in Thickness
- C1002 Specification for Steel Self-Piercing Tapping Screws for Application of Gypsum Panel Products or Metal Plaster Bases to Wood Studs or Steel Studs
- C1063 Specification for Installation of Lathing and Furring to Receive Interior and Exterior Portland Cement-Based Plaster
- C1787 Specification for Installation of Non Metallic Plaster Bases (Lath) Used with Portland Cement Based Plaster in Vertical Wall Applications
- D1784 Classification System and Basis for Specification for Rigid Poly(Vinyl Chloride) (PVC) Compounds and Chlorinated Poly(Vinyl Chloride) (CPVC) Compounds
- D4216 Specification for Rigid Poly(Vinyl Chloride) (PVC) and Related PVC and Chlorinated Poly(Vinyl Chloride) (CPVC) Building Products Compounds
- F1667 Specification for Driven Fasteners: Nails, Spikes, and Staples

2.2 AISI Standards:³

- AISI S220 North American Standard for Cold-Formed Steel Framing—Nonstructural Members
- AISI S240 North American Standard for Cold-Formed Steel Structural Framing

3. Terminology

3.1 Definitions:

3.1.1 Definitions shall be in accordance with Specification C1063.

3.2 Definitions of Terms Specific to This Standard:

3.2.1 *capture flange, n*—the narrow flange element of a lathing accessory that projects from a ground and returns onto the exterior stucco cladding surface to conceal the gap between the ground and stucco cladding.

³ Available from American Iron and Steel (AISI), 25 Massachusetts Avenue, NW, Suite 800, Washington, DC 20001, <https://www.steel.org>.

¹ This specification is under the jurisdiction of ASTM Committee C11 on Gypsum and Related Building Materials and Systems and is the direct responsibility of Subcommittee C11.02 on Specifications and Test Methods for Accessories and Related Products.

Current edition approved June 1, 2022. Published July 2022. Originally approved in 2017. Last previous edition approved in 2021 as C1861 – 21a. DOI: 10.1520/C1861-22.

² For referenced ASTM standards, visit the ASTM website, www.astm.org, or contact ASTM Customer Service at service@astm.org. For *Annual Book of ASTM Standards* volume information, refer to the standard's Document Summary page on the ASTM website.

*A Summary of Changes section appears at the end of this standard

3.2.2 *cement plaster panel area, n*—the surface of a cement plaster area between lathing accessory grounds.

3.2.3 *drainage surface, n*—the sloped or non-sloped, perforated or non-perforated surface element of a lathing accessory that facilitates a drainage function, by directing water from behind the stucco cladding to the exterior of the stucco cladding.

3.2.4 *drip flange, n*—the narrow flange element of a lathing accessory that facilitates a drainage function, projects from a drainage surface and directs water to the exterior of the stucco cladding.

3.2.5 *fastener, n*—a nail, screw, staple or power actuated fastener.

3.2.6 *flexible pleat, n*—the flexible element of a control joint lathing accessory that accommodates movement of the cement plaster cladding assembly caused by shrinkage and thermal variations.

3.2.7 *ground, n*—the element of a lathing accessory that provides an edge, end, or termination for a cement plaster panel area, with a ground dimension to assist in cement plaster thickness control.

3.2.8 *key attachment flange, n*—the attachment flange element of a lathing accessory that is full of holes or is expanded sheet metal that provides a means for accurate alignment, facilitates complete embedment of the key attachment flange and adjacent lath by cement plaster, and is used to attach the lathing accessory.

3.2.9 *movement gap, n*—the element of an expansion joint lathing accessory that accommodates some degree of movement in the stucco cladding assembly caused by movement of the building, the substrate, or its components.

3.2.10 *screed, n*—synonymous with *ground*.

3.2.11 *solid attachment flange, n*—the solid attachment flange element of a lathing or furring accessory that provides a means for accurate alignment, facilitates drainage where drainage is required by integration of the solid attachment flange with the water-resistive barrier, and which has no holes except for optional fastener holes used to fasten the lathing accessory.

3.3 Illustrations (Fig. 1) are intended to generically depict examples of common lathing and furring accessory shapes and fasteners, by depicting their functional elements in relationship to each other, without literally depicting specific manufactured products. Variations of lathing and furring accessory shapes and fasteners illustrated shall be acceptable when the function and performance is equivalent to or exceeds the illustrated accessory or fastener.

4. Materials and Manufacture

4.1 General:

4.1.1 Lathing and furring accessories, and fasteners shall be free of deleterious amounts of rust, oil, or other foreign matter that could cause bond failure or unsightly discoloration.

4.1.2 Lathing and furring accessories shall include key attachment flanges or solid attachment flanges. Solid attachment flanges shall accommodate self-piercing fasteners with-

out deforming the attachment flange or shall include optional fastener holes used to fasten the lathing accessory.

4.1.3 Lathing and furring accessories shall facilitate lathing and furring installation, cement plaster application, and functionality of the completed stucco cladding assembly. Lathing and furring accessories shall be configured to serve one or more functions such as to assist in cement plaster thickness control, to reinforce cement plaster corners, to facilitate drainage, to reduce cracking by accommodating movement, to separate cement plaster from dissimilar materials, load bearing members and penetrating elements, and to provide an edge, end, or termination for a cement plaster panel area.

4.1.4 Lathing accessories shall be configured to accommodate application of the specified cement plaster thickness. The ground dimension of lathing accessories shall be determined by the specified thickness of the cement plaster with consideration of the installed configuration of the lathing accessory to the lath (lathing accessory located under or over the lath).

4.1.5 Lathing accessories serving a drainage function shall include a drainage surface and a solid attachment flange.

4.2 Materials:

4.2.1 *Steel*—Specification **A653/A653M**, with a G60 coating.

4.2.2 *Stainless Steel*—Specification **A240/A240M**, Type 304 or 316.

4.2.3 *Zinc Alloy*—Specification **B69**, 99 % pure zinc.

4.2.4 *Anodized Aluminum Alloy*—Specification **B221**.

4.2.5 *PVC and CPVC Plastic*—Specification **D1784** or **D4216**.

4.2.6 Lathing accessories shall be corrosion resistant and fabricated from galvanized (zinc-coated) steel, stainless steel, rigid PVC or CPVC plastic, zinc alloy, or anodized aluminum alloy. Lathing accessory base material and minimum thickness shall be as indicated in **Table 1**.

4.2.7 Fasteners shall be fabricated from steel or stainless steel and comply with Specifications **C954**, **C1002**, and **F1667** as applicable. Steel fasteners shall have a corrosion resistant plating or coating.

4.2.8 Wire shall be corrosion resistant steel wire, annealed, Specification **A641/A641M** with a Class I galvanized coating, or stainless steel wire, annealed, Specification **A580/A580M**.

4.2.9 Adhesive shall be a materials compatible, exterior, gun-grade, construction adhesive. Expandable foam adhesives are prohibited.

4.2.10 Clips shall be formed from galvanized steel wire, Specification **A641/A641M** or steel sheet, Specification **A653/A653M**, depending on use and manufacturer's requirements.

4.2.11 Rod hanger and strap hanger shall be mild steel, and galvanized, zinc electroplated, or protected with a rust-inhibiting paint.

4.2.12 U-Channel furring shall be cold-formed steel, 33 000 psi (228 MPa) yield strength, 0.0538 in. (1.37 mm) minimum bare steel thickness.

4.2.12.1 U-Channel furring protective coating:

4.2.12.2 U-Channel furring for use in interior applications shall have a protective coating conforming to the requirements of **AISI S220**.

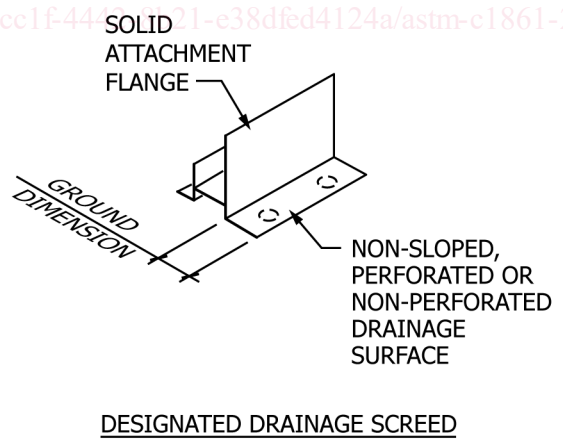
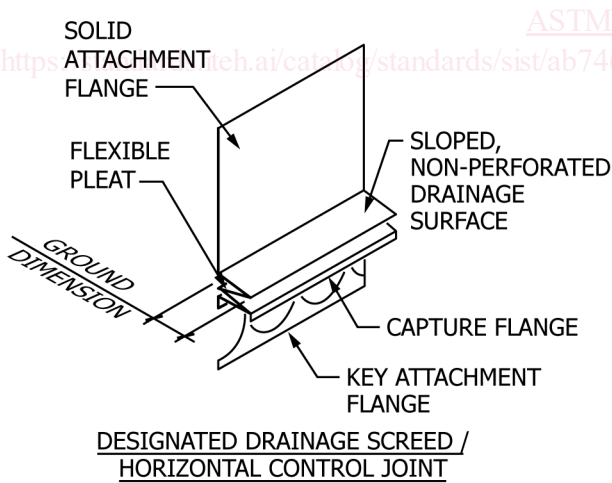
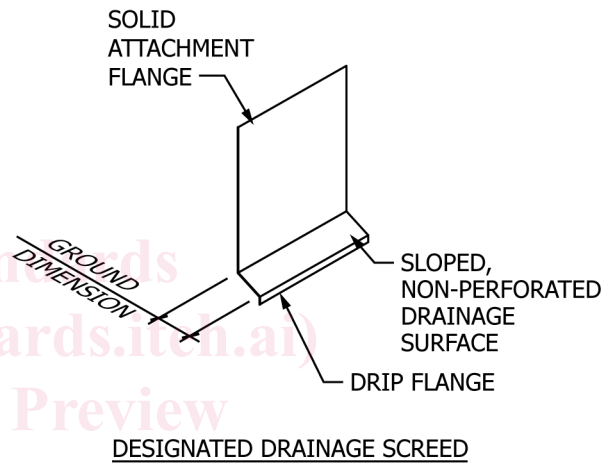
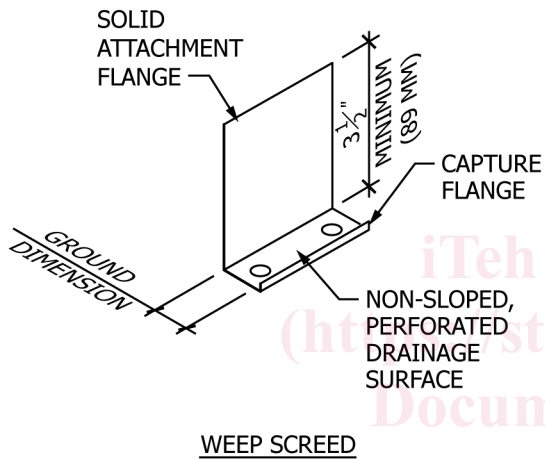
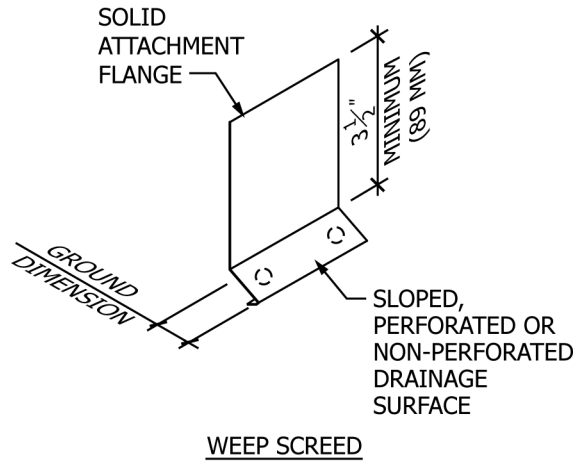
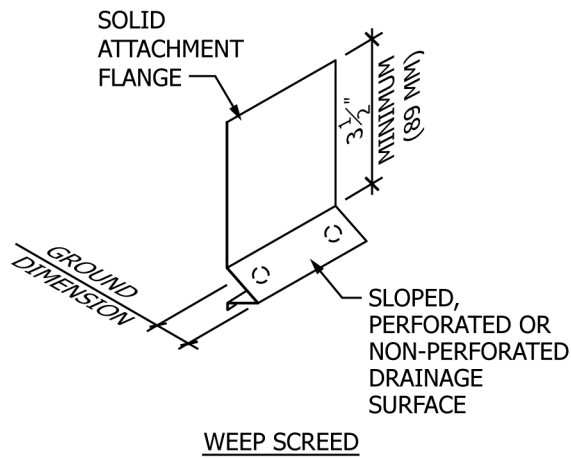

FIG. 1 Lathing and Furring Accessories, and Fasteners

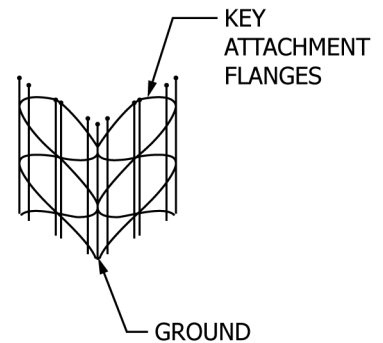
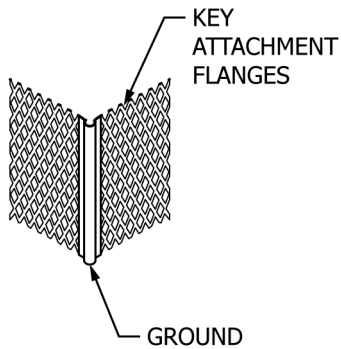
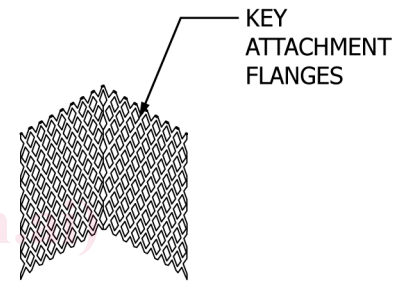
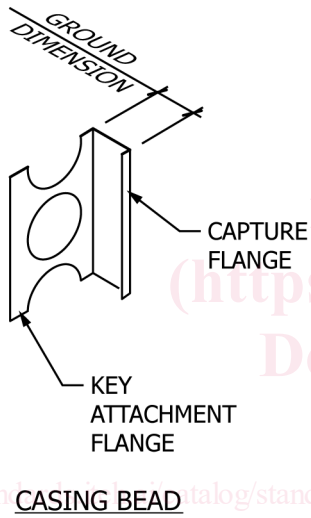
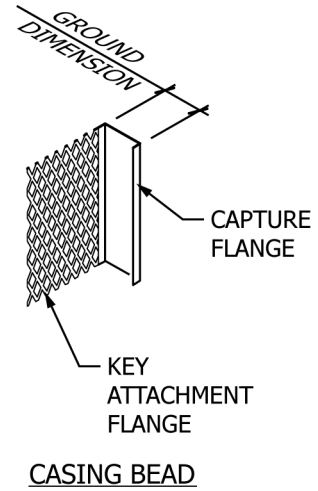
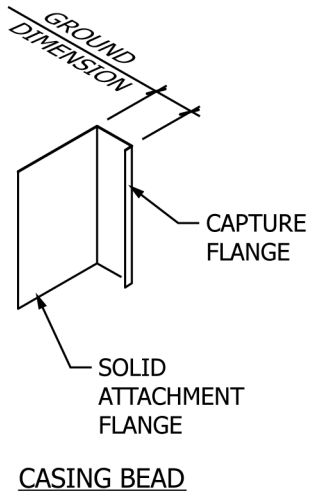
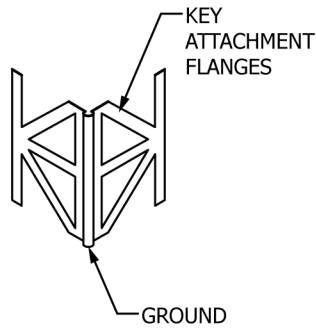
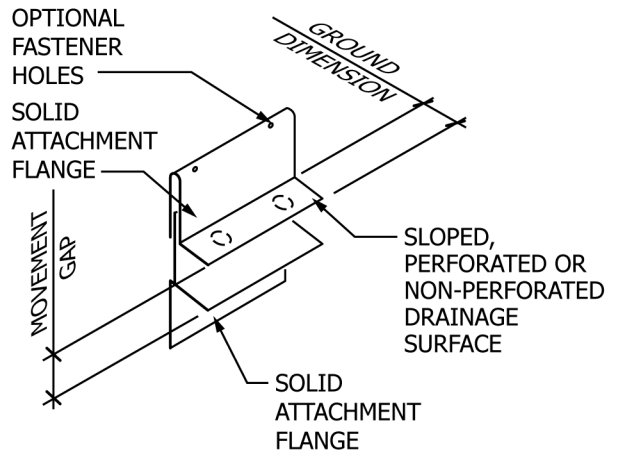

FIG. 1 Lathing and Furring Accessories, and Fasteners (continued)



EXTERNAL CORNER REINFORCEMENT



EXPANSION JOINT - HORIZONTAL

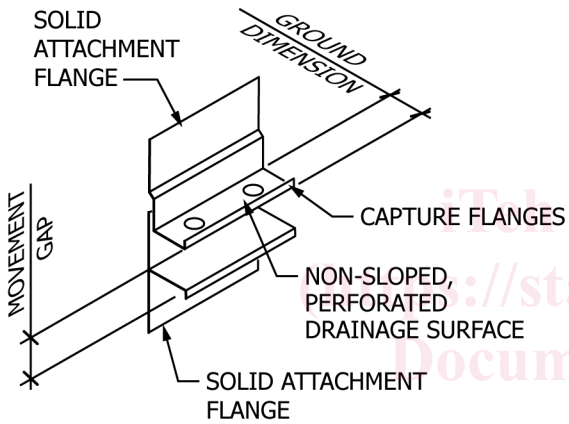

EXPANSION JOINT - HORIZONTAL

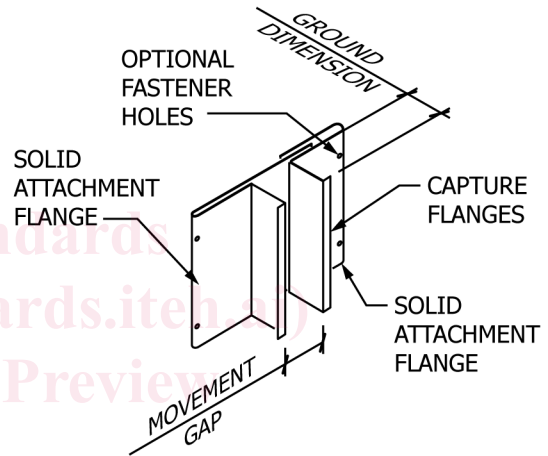

EXPANSION JOINT - VERTICAL

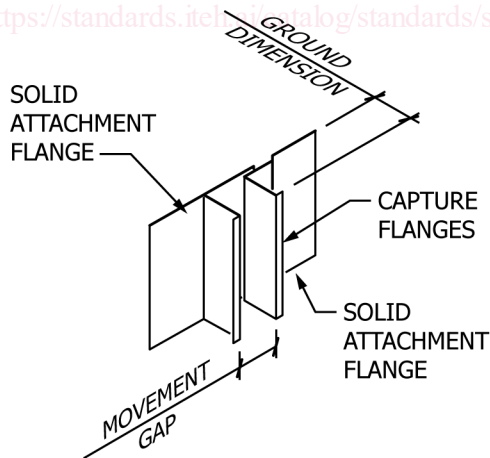

EXPANSION JOINT - VERTICAL

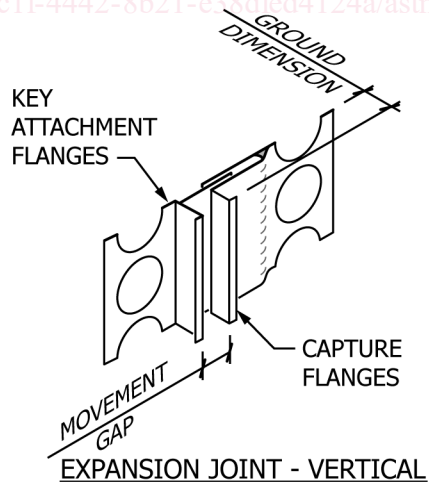

EXPANSION JOINT - VERTICAL

FIG. 1 Lathing and Furring Accessories, and Fasteners (continued)

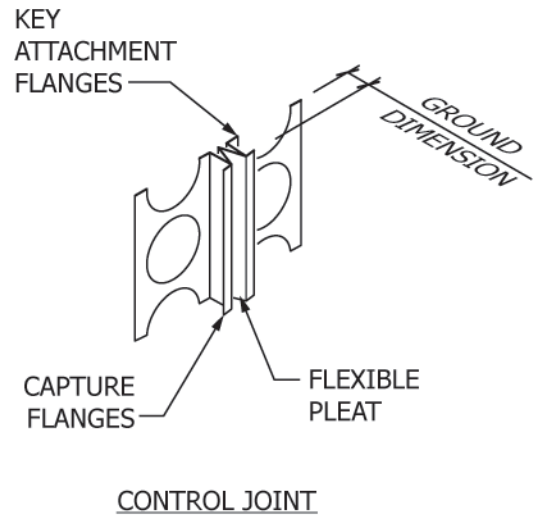
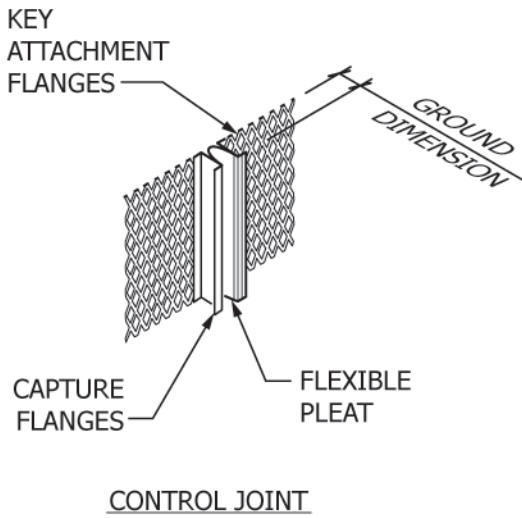

STRAP HANGER

iTeh Standards
 (https://standards.itih.ai)
 Document Preview



ROD HANGER

ASTM C1861-22

<https://standards.itih.ai/catalog/standards/sist/ab7465e9-cc1f-4442-8b21-e38dfed4124a/astm-c1861-22>



THREADED ROD HANGER

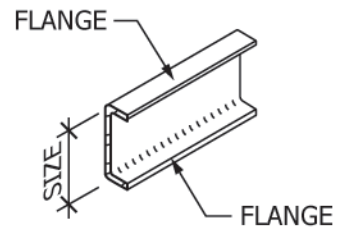

U-CHANNEL FURRING

FIG. 1 Lathing and Furring Accessories, and Fasteners (continued)

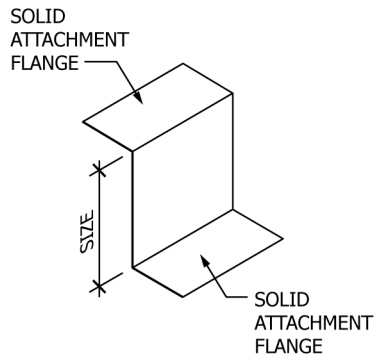

Z-FURRING

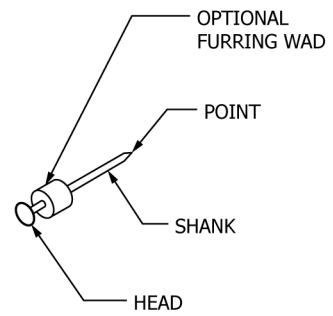

NAIL

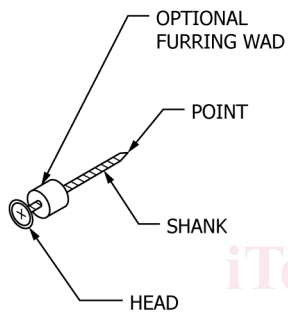

SCREW

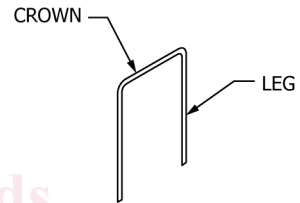

STAPLE

iTeh Standards
 (https://standards.itih.ai)
 Document Preview

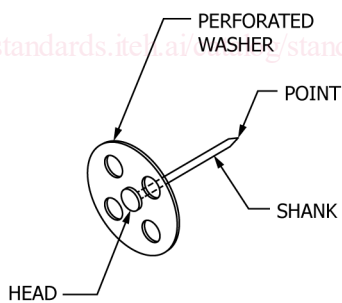

POWER-ACTUATED FASTENER

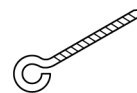

EYE SCREW

ASTM C1861-22
<https://standards.itih.ai/standards/sist/ab7465e9-cc1f-4442-8b21-e38dfed4124a/astm-c1861-22>

FIG. 1 Lathing and Furring Accessories, and Fasteners (continued)