



Designation: **E1444/E1444M—22 E1444/E1444M – 22a**

## Standard Practice for Magnetic Particle Testing for Aerospace<sup>1</sup>

This standard is issued under the fixed designation E1444/E1444M; the number immediately following the designation indicates the year of original adoption or, in the case of revision, the year of last revision. A number in parentheses indicates the year of last reapproval. A superscript epsilon ( $\epsilon$ ) indicates an editorial change since the last revision or reapproval.

*This standard has been approved for use by agencies of the U.S. Department of Defense.*

### 1. Scope\*

1.1 This practice establishes minimum requirements for magnetic particle testing used for the detection of surface or slightly subsurface discontinuities in ferromagnetic material. This practice is intended for aerospace applications using the wet fluorescent method. Refer to Practice **E3024/E3024M** for industrial applications. Guide **E709** can be used in conjunction with this practice as a tutorial.

NOTE 1—This practice replaces MIL-STD-1949.

1.2 The magnetic particle testing method is used to detect cracks, laps, seams, inclusions, and other discontinuities on or near the surface of ferromagnetic materials. Magnetic particle testing may be applied to raw material, billets, finished and semi-finished materials, welds, and in-service parts. Magnetic particle testing is not applicable to non-ferromagnetic metals and alloys such as austenitic stainless steels. See **Appendix X1** for additional information.

1.3 Portable battery powered electromagnetic yokes are outside the scope of this practice.

1.4 All areas of this practice may be open to agreement between the cognizant engineering organization and the supplier, or specific direction from the cognizant engineering organization.

1.5 This standard is a combined standard, an ASTM standard in which rationalized SI units and inch-pound units are included in the same standard, with each system of units to be regarded separately as standard.

1.5.1 *Units*—The values stated in either SI units or inch-pound units are to be regarded separately as standard. The values stated in each system are not necessarily exact equivalents; therefore, to ensure conformance with the standard, each system shall be used independently of the other, and values from the two systems shall not be combined.

1.6 *This standard does not purport to address all of the safety concerns, if any, associated with its use. It is the responsibility of the user of this standard to establish appropriate safety, health, and environmental practices and determine the applicability of regulatory limitations prior to use.*

1.7 *This international standard was developed in accordance with internationally recognized principles on standardization established in the Decision on Principles for the Development of International Standards, Guides and Recommendations issued by the World Trade Organization Technical Barriers to Trade (TBT) Committee.*

<sup>1</sup> This practice is under the jurisdiction of ASTM Committee **E07** on Nondestructive Testing and is the direct responsibility of Subcommittee **E07.03** on Liquid Penetrant and Magnetic Particle Methods.

Current edition approved ~~June 1, 2022~~ July 1, 2022. Published July 2022. Originally approved in 1991. Last previous edition approved in ~~2021~~ 2022 as **E1444/E1444M – 21**/**E1444/E1444M – 22**. DOI: ~~10.1520/E1444-E1444M-22~~ 10.1520/E1444\_E1444M-22A.

\*A Summary of Changes section appears at the end of this standard

## 2. Referenced Documents

2.1 The following documents form a part of this practice to the extent specified herein.

### 2.2 *ASTM Standards:*<sup>2</sup>

[E543 Specification for Agencies Performing Nondestructive Testing](#)

[E709 Guide for Magnetic Particle Testing](#)

[E1316 Terminology for Nondestructive Examinations](#)

[E2297 Guide for Use of UV-A and Visible Light Sources and Meters used in the Liquid Penetrant and Magnetic Particle Methods](#)

[E3022 Practice for Measurement of Emission Characteristics and Requirements for LED UV-A Lamps Used in Fluorescent Penetrant and Magnetic Particle Testing](#)

[E3024/E3024M Practice for Magnetic Particle Testing for General Industry](#)

### 2.3 *ASNT Documents:*<sup>3</sup>

[SNT-TC-1A Personnel Qualification and Certification in Nondestructive Testing](#)

[ANSI/ASNT CP-189 Standard for Qualification and Certification of NDT Personnel](#)

### 2.4 *SAE-AMS Documents:*<sup>4,5</sup>

[AMS 2175 Castings, Classification and Inspection of](#)

[AMS 2641 Magnetic Particle Inspection Vehicle](#)

[AMS 3044 Magnetic Particles, Fluorescent, Wet Method, Dry Powder](#)

[AMS 3045 Magnetic Particles, Fluorescent, Wet Method, Oil Vehicle, Ready-To-Use](#)

[AMS 3046 Magnetic Particles, Fluorescent, Wet Method, Oil Vehicle, Aerosol Packaged](#)<sup>5</sup>

[AMS 5355 Investment Castings](#)

[AS 4792 Water Conditioning Agents for Aqueous Magnetic Particle Inspection](#)

[AS 5282 Tool Steel Ring Standard for Magnetic Particle Inspection](#)

[AS 5371 Reference Standards Notched Shims for Magnetic Particle Inspection](#)

[SAE AMS-STD-595 Colors Used in Government Procurement](#)

### 2.5 *Federal Standard:*<sup>4,6</sup>

[FED-STD-313 Material Safety Data, Transportation Data and Disposal Data for Hazardous Materials Furnished to Government Activities](#)

### 2.6 *Military Standards:*<sup>4,6</sup>

[A-A-59230 Fluid, Magnetic Particle Inspection, Suspension](#)

[MIL-STD-1949 Inspection, Magnetic Particle](#)

### 2.7 *OSHA Document:*<sup>7</sup>

[29 CFR 1910.1200 Hazard Communication](#)

### 2.8 *ANSI Document:*<sup>4,8</sup>

[ANSI/NCSL Z540.3 General Requirement for Calibration Laboratories and Measuring Test Equipment](#)

### 2.9 *ISO Standards:*<sup>9</sup>

[ISO 10012 Measurement Management Systems—Requirements for Measurement Processes and Measuring Equipment \(ISO 10012 is not intended as a substitute for, or as an addition to, the requirements of ISO/IEC 17025.\)](#)

[ISO 9712 Non-destructive Testing — Qualification and Certification of NDT Personnel](#)

[ISO/IEC 17025 General Requirements for the Competence of Testing and Calibration Laboratories](#)

### 2.10 *AIA Document:*<sup>10</sup>

[NAS 410 NAS Certification and Qualification of Nondestructive Test Personnel](#)

### 2.11 *ASD-STAN Document:*<sup>11</sup>

[EN 4179 Qualification and Approval of Personnel for Non-Destructive Testing](#)

<sup>2</sup> For referenced ASTM standards, visit the ASTM website, [www.astm.org](http://www.astm.org), or contact ASTM Customer Service at [service@astm.org](mailto:service@astm.org). For *Annual Book of ASTM Standards* volume information, refer to the standard's Document Summary page on the ASTM website.

<sup>3</sup> Available from American Society for Nondestructive Testing (ASNT), P.O. Box 28518, 1711 Arlington Ln., Columbus, OH 43228-0518, <http://www.asnt.org>.

<sup>4</sup> Copies of standards, specifications, drawings, and publications required by manufacturers in connection with specification acquisition should be obtained from the contracting activity or as directed by the contracting officer.

<sup>5</sup> Available from SAE International (SAE), 400 Commonwealth Dr., Warrendale, PA 15096-0001, <http://www.sae.org>.

<sup>6</sup> Available from Standardization Documents Order Desk, DODSSP, Bldg. 4, Section D, 700 Robbins Ave., Philadelphia, PA 19111-5098, <http://dodssp.daps.dla.mil>.

<sup>7</sup> Available from U.S. Government Printing Office Superintendent of Documents, 732 N. Capitol St., NW, Mail Stop: SDE, Washington, DC 20401, <http://www.access.gpo.gov>.

<sup>8</sup> Available from American National Standards Institute (ANSI), 25 W. 43rd St., 4th Floor, New York, NY 10036, <http://www.ansi.org>.

<sup>9</sup> Available from International Organization for Standardization (ISO), ISO Central Secretariat, Chemin de Blandonnet 8, CP 401, 1214 Vernier, Geneva, Switzerland, <https://www.iso.org>.

<sup>10</sup> Available from Aerospace Industries Association of America, Inc. (AIA), 1000 Wilson Blvd., Suite 1700, Arlington, VA 22209-3928, <http://www.aia-aerospace.org>.

<sup>11</sup> Available from ASD-STAN, [asd-stan.org](http://asd-stan.org).

2.12 *Order of Precedence*—In the event of conflict between the text of this practice and the referenced documents cited herein, the text of this practice takes precedence.

### 3. Terminology

3.1 *Definitions*—The definitions relating to magnetic particle testing, which appear in Terminology E1316, shall apply to the terms used in this practice.

### 4. Significance and Use

4.1 *Description of Process*—Magnetic particle testing consists of magnetizing the area to be examined, applying suitably prepared magnetic particles while the area is magnetized, and subsequently interpreting and evaluating any resulting particle accumulations. Maximum detectability occurs when the discontinuity is positioned on the surface and perpendicular to the magnetic flux.

4.2 This practice establishes the basic parameters for controlling the application of the magnetic particle testing method. This practice is written so that it can be specified on the engineering drawing, specification, or contract. It is not a detailed how-to procedure to be used by the examination personnel and, therefore, must be supplemented by a detailed written procedure that conforms to the requirements of this practice.

### 5. General Practice

5.1 *Personnel Qualification*—Personnel performing examinations in accordance with this practice shall be qualified and certified in accordance with SNT-TC-1A, ANSI/ASNT CP-189, NAS 410, EN4179, ISO 9712, or as specified in the contract or purchase order.

5.2 *Agency Qualification*—The agency performing this practice may be evaluated in accordance with Specification E543.

5.3 *Written Procedure*—Magnetic particle testing shall be performed in accordance with a written procedure applicable to the part or group of parts under examination. The procedure shall be in accordance with the requirements of this practice. The process, when conducted in accordance with the written procedure, shall be capable of detecting discontinuities specified in the acceptance criteria. The written procedure may be general if it clearly applies to all of the specified parts being examined and meets the requirements of this practice. All written procedures, including technique sheets for specific parts, shall be approved by an individual qualified and certified at Level 3 (III) for magnetic particle testing in accordance with the requirements of 5.1. Procedures shall be submitted to the cognizant engineering organization for review, or approval, or both, when requested.

5.3.1 *Elements of the Written Procedure*—The written procedure shall include at least the following elements, either directly or by reference to the applicable documents:

5.3.1.1 Name and address of facility to which the procedure applies, containing the unique procedure identification number and the date it was written;

5.3.1.2 Identification of the part(s) to which the procedure applies; this shall include the material, or alloy, or both;

5.3.1.3 For new components, sequence of magnetic particle testing as related to manufacturing process operation (for example, post plating, after heat treat, etc.);

5.3.1.4 Identification of test parts used for system performance verification (see 7.1.1 and 7.1.2);

5.3.1.5 Process controls (see Table 1);

5.3.1.6 Identification of the areas of the part to be examined and include an illustration, a drawing, or photos as necessary;

5.3.1.7 Part preparation required before examination;

5.3.1.8 Directions for positioning the item with respect to the magnetizing equipment;

5.3.1.9 The type of magnetizing current and the equipment to be used;

**TABLE 1 Process Controls and Calibrations**

Item	Maximum Time Between Verification <sup>A</sup>	Paragraph
Lighting: <sup>B</sup>		
Visible light intensity	Weekly	7.3.1.1
Ambient light intensity	Weekly	7.3.1.2
UV–A lamp intensity	Daily	7.3.2, 7.4.5
Battery powered	Prior to and after each use	7.4.5.2
UV–A lamp intensity check		
UV–A lamp integrity <sup>C</sup>	Daily	7.3.2
System Performance: <sup>B</sup>	Daily	7.1, 7.1.1, 7.1.2
Wet particle concentration	8 hours, or every shift change	7.2.1.1
Wet particle contamination: <sup>B</sup>	1 week	7.2.1.2
Water break test	Daily	7.2.2
Equipment calibration check: <sup>B</sup>		
Ammeter accuracy	6 months	7.4.1
Timer control	6 months	7.4.2
Quick break	6 months	7.4.3
Yoke dead weight check	6 months	7.4.4
UV–A Radiometer and Photometer	6 months	7.4.7
Hall-Effect Gaussmeter or Field Indicator accuracy	6 months	7.4.6

<sup>A</sup> When the test system is in operation.

<sup>B</sup> The maximum time between verifications may be reduced or extended when substantiated by actual technical/reliability data.

<sup>C</sup> Need not be recorded.

5.3.1.10 Method of establishing the magnetization (head, coil, yoke, cable wrap, etc.);

5.3.1.11 Directions of magnetization to be used, the order in which they are applied, and any demagnetization procedures to be used between shots;

5.3.1.12 The current level, or the number of ampere turns, to be used and the duration of its application;

5.3.1.13 Type of magnetic particle material to be used, the particle concentration limits, and the method and equipment to be used for its application. If a suspension dwell time is required, the length of suspension drain time prior to examination shall be defined;

5.3.1.14 Type of records and method of marking parts after examination;

5.3.1.15 Acceptance requirements to be used for evaluating indications, arc burns, and disposition of parts after evaluation;

5.3.1.16 Post-examination demagnetization and cleaning requirements; and

5.3.1.17 The method and measurement frequency will be defined for meeting the minimum examination intensity for all UV-A lamps, including battery-powered lamps. Any requirements for documentation of the measurements will also be defined.

5.4 *Examination Sequence*—Perform magnetic particle examination after all operations which might cause or reveal discontinuities. Such operations include, but are not limited to, forging, heat treating, electroplating, forming, welding, grinding, straightening, machining, and proof loading.

5.4.1 Perform magnetic particle examination prior to shot peening (to provide a beneficial compressive layer) and prior to applying protective finishes such as priming, painting, plating (see 5.4.3 through 5.4.3.5), or other coatings.

5.4.2 In-process examinations may not be substituted for final examination.

5.4.3 *Plating and Coatings*—Examine parts which will receive either a plating or coating as follows:

5.4.3.1 Examination is required prior to all non-electroplated coatings.

5.4.3.2 Electroplated surfaces with a final plating thickness of 0.0008 in. [0.02 mm] or less shall be examined either before or after electroplating, or grinding, or both.

5.4.3.3 Electroplated surfaces with a final plating thickness of between 0.0008 in. [0.02 mm] and 0.0050 in. [0.13 mm] shall be examined both before and after electroplating, or grinding, or both, of electroplated surfaces.

(1) Electroplated surfaces with a final plating thickness of 0.0050 in. [0.13 mm] or greater shall be examined before electroplating, or grinding, or both, of electroplated surfaces.

(2) Magnetic particle examination after electroplating is not required for steels with a tensile strength less than or equal to 160 ksi.

5.4.3.4 Use caution when examining parts with an electroplated nickel coating as indications may form from the resulting leakage fields within the nickel plating itself.

5.4.3.5 For in-service examination, plating or coatings do not require removal prior to examination unless they are damaged, or they interfere with the examination process.

## 5.5 Materials:

5.5.1 *Wet Particle Requirements*—Wet particles shall meet the requirements of AMS 3044, 3045, or 3046, as applicable.

5.5.2 *Suspension Vehicles*—The suspension vehicle for the wet method shall be a light petroleum distillate conforming to AMS 2641 (Type I) or A-A-59230, or a suitably conditioned water that conforms to the requirements of 5.5.3. When approved by the contracting agency, AMS 2641 (Type II) may be used. When specified, the oil suspension vehicle shall meet the salient characteristics specified in A-A-59230.

5.5.3 *Conditioned Water Vehicle*—When water is used as a suspension vehicle for magnetic particles, the conditioning agents used shall comply with AS 4792. Proper wetting shall be determined by a water break test (see 7.2.2). Smoother surfaces generally require a greater percent of wetting agent than rough surfaces. Foaming of the bath must be minimized to the point that it does not interfere with the examination process.

5.5.3.1 *Water Vehicle Conditioning Agents*—Any agents added to the water vehicle for any purpose shall conform to the requirements of the particle manufacturer.

5.5.4 *Particle Concentration*—The concentration of particles in the suspension bath shall be as specified in the written procedure. Particle concentrations outside of the range of 0.1 to 0.4 mL in a 100 mL bath sample for fluorescent particles shall not be used.

<https://standards.iteh.ai/catalog/standards/sist/cdbddc66-2c65-4278-8105-a064fe042fbf/astm-e1444-e1444m-22a>  
5.6 *Safety*—The safe handling of magnetic particles and oil vehicles, water baths, and water conditioner concentrates is governed by the suppliers' Material Safety Data Sheets (MSDS). Material Safety Data Sheets, conforming to 29 CFR 1910.1200, or equivalent, must be provided by the supplier to any user and shall be prepared in accordance with FED-STD-313.

5.6.1 *Flammability*—Flash point of oil vehicles shall be in accordance with AMS 2641, Type I carriers. The suppliers' MSDS shall certify the flash point.

5.6.2 *Personnel Hazards*—Precautions against inhalation, skin contact, and eye exposure are detailed in the suppliers' MSDS. These precautions shall be observed.

5.6.3 *Electrical Hazards*—Magnetizing equipment shall be maintained properly to prevent personnel hazards from electrical short circuits. Care must be taken to reduce arcing and the possible ignition of oil baths.

5.6.4 *UV-A Lamps*—Replace cracked or broken ultraviolet filters immediately. Broken filters can allow harmful ultraviolet energy to be emitted and must be replaced immediately. Spectacles designed to absorb ultraviolet energy are suggested for close, high-intensity UV-A examination. LED UV-A lamps used for evaluation purposes shall comply with Practice E3022. See 7.3.2.

## 6. Specific Practice

### 6.1 Preparation of Parts for Testing:

6.1.1 *Pre-examination Demagnetization*—The part shall be demagnetized per 6.7.1 before testing if prior operations have produced a residual magnetic field that may interfere with the examination.

6.1.2 *Surface Cleanliness and Finish*—The surface of the part to be examined shall be essentially smooth, clean, dry, and free of oil, scale, machining marks, or other contaminants or conditions that might interfere with the efficiency of the examination.

6.1.3 *Plugging and Masking*—Plugging and masking are required when specified by the cognizant engineering organization.

6.1.4 All areas on the part where electrical contact is made shall be sufficiently clean to prevent electrical arcing.

6.1.5 *Aircraft-Quality Steel Cleanliness*—The examination of aircraft-quality steel for cleanliness using magnetic particle testing shall be as appropriate to the type of steel being inspected. However, testing of parts fabricated from this material shall be in accordance with the requirements of this practice.

## 6.2 *Magnetization Methods:*

6.2.1 *Types of Magnetizing Current*—The types of currents used for magnetic particle testing are full-wave rectified current (1 or 3 phase), half-wave rectified current, and alternating current. The equipment used shall fulfill the magnetizing and demagnetizing requirements adequately, as outlined herein, without damage to the part under examination, and it shall include the necessary features required for safe operation.

6.2.2 *Yokes*—When using yokes (electromagnetic probes) for magnetic particle testing, they shall meet the requirements of 7.4.4.

6.2.3 *Magnetizing Current Application*—Alternating current is to be only used for the detection of discontinuities open to the surface. Full-wave direct current has the deepest possible penetration and must be used for examination of sub-surface discontinuities when using the wet magnetic particle method. Half-wave direct current can also be used for examination of sub-surface discontinuities, and due to the pulsating nature of the waveform, it has the advantage of increased particle mobility.

6.2.4 *Magnetic Field Directions*—Discontinuities are difficult to detect by the magnetic particle method when they make an angle less than 45° to the direction of magnetization. To ensure the detection of discontinuities in any direction, each part must be magnetized in a minimum of two directions at approximately right angles to each other. Depending on part geometry, this may consist of circular magnetization in two or more directions, multiple circular and longitudinal magnetization, or of longitudinal magnetization in two or more directions.

NOTE 2—For further guidance, see Guide E709.

6.2.5 *Multidirectional Magnetization*—Multidirectional magnetization may be used to fulfill the requirement for magnetization in two or more directions if it is demonstrated that it is effective in all areas, which require examination as practical. Test parts in accordance with 6.3.1.1 or shims manufactured to the requirements of AS 5371, or as otherwise approved by the cognizant engineering organization, shall be used to verify field direction, strength, and balance in multidirectional magnetization. Balancing of the combined magnetic field is critical and an adequate balance must be visually demonstrated to be effective in all areas which require examination. The particle application must be timed so that the magnetization levels reach full value in all directions while the particles are mobile on the surface under examination. The residual method shall only be used with the approval of the cognizant engineering organization.

6.2.6 *Direct Magnetization*—Direct magnetization is accomplished by passing current directly through the part under examination. Electrical contact is made to the part using head and tail stock, clamps, or by other means. Caution shall be taken to ensure that the electrical current is not flowing while contacts are being applied or removed and that excessive heating does not occur in any area of the part. Unless otherwise specified by the cognizant engineering organization, prods or magnetic leeches shall not be used for the examination of aerospace components or flight hardware.

6.2.7 *Indirect Magnetization*—Indirect part magnetization uses pre-formed coils, cable wraps, yokes, field (flux) flow fixtures, or a central conductor to induce a magnetic field in a part when no direct electrical contact is made.

6.2.7.1 *Offset Internal Conductor Circular Magnetization*—The circular field from an offset internal conductor is illustrated in Fig. 1. The extent of the field is dependent upon the fill factor of the bar or pipe used and the amperage applied. The effective radial field coverage of the magnetizing shot shall be verified per paragraph 6.3.1. Examination shall be performed on all relevant surfaces prior to rotation of the hollow part on the conductor to provide full radial coverage.

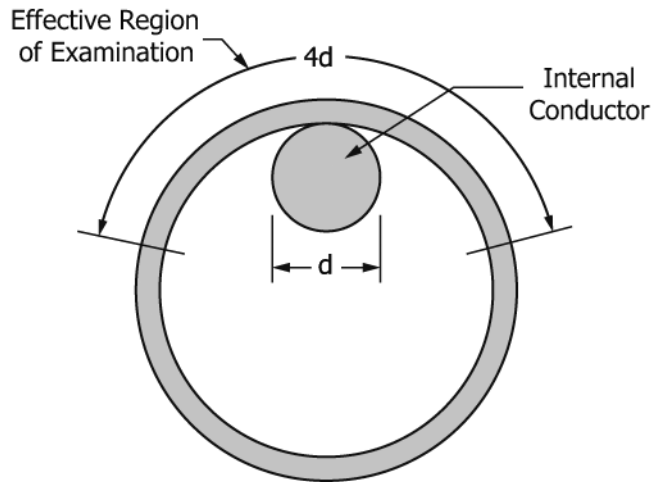

FIG. 1 The Effective Region of Examination When Using an Offset Internal Conductor is Approximately Equal to Four Times the Diameter of the Conductor as Indicated

6.2.8 *Induced Current Magnetization*—Induced current magnetization (toroidal or circumferential field) is accomplished by inductively coupling a part to an electrical coil in order to create a suitable current flow within the part as illustrated in Fig. 2. This method is often advantageous on ring-shaped parts with a central aperture and with an  $L/D$  ratio less than three, especially where the elimination of arcing or burning is of vital importance.

6.2.9 *Parallel Current Induced Magnetization*—This method of magnetization may occur when a ferromagnetic part is placed alongside and parallel to a current-carrying conductor. A magnetic field will be induced in the part that is more transverse than circular. This type of magnetization shall not be used for magnetic particle testing unless approved by the cognizant engineering organization.

6.2.10 *Magnetization of Aerospace Lifting Hardware*—The use of permanent magnets, electromagnetic yokes, or coil wraps on aerospace lifting hardware must be approved by the cognizant engineering organization.

6.3 *Magnetic Field Strength:* <http://log/standards/sist/cdbddc66-2c65-4278-8105-a064fe042fbf/astm-e1444-e1444m-22a>

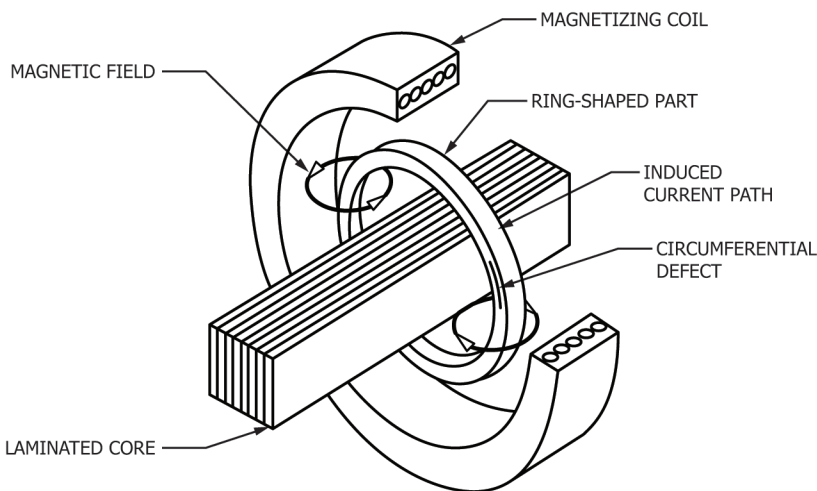
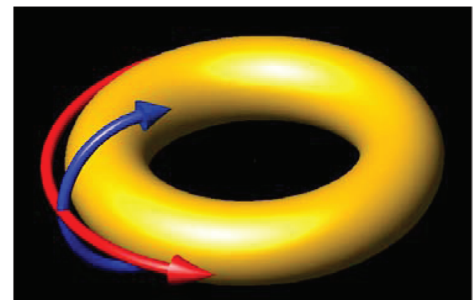

Figure A



(The eddy current is represented in red and the resulting magnetic field is represented in blue.)

Figure B

NOTE 1—Only a changing magnetic field will generate a resulting eddy current in the ring-shaped part, such as when the magnetic field in the magnetizing coil suddenly collapses, or when using a moving waveform such as AC; no eddy current is produced in the part by a non-moving waveform. The resultant toroidal shaped magnetic field may be used to detect circumferential discontinuities in the part.

FIG. 2 Example of Induced Current Magnetization

6.3.1 *Magnetic Field Strength*—The applied magnetic field shall have sufficient strength to produce satisfactory indications, but it must not be so strong that it causes the masking of relevant indications by nonrelevant accumulations of magnetic particles. Adequate magnetic field strength may be determined by one or a combination of the following methods:

6.3.1.1 In unidirectional, or multidirectional magnetizing applications, by examining parts having known or artificial discontinuities of the type, size, and location specified in the acceptance requirements or by using the notched shims as defined in [Annex A1](#);

6.3.1.2 In unidirectional magnetizing applications only, by using a Hall-Effect probe gaussmeter capable of measuring the peak values of the tangential field as described in [Annex A4](#). Tangential-field strengths shall have a minimum value of 30 Gauss ( $30 \times 10^{-4}$  Tesla [T]) when measured at the part surface using a transverse Hall-Effect probe gaussmeter as described in [Annex A4](#). The maximum Gauss value derived is limited by the restrictions of [6.3.1](#). See Guide [E709](#) for additional guidance.

6.3.2 *Longitudinal Magnetization Using Coils*—Longitudinal magnetization is often accomplished by passing current through a coil encircling the part, or section of the part, to be examined (that is, by using a coil shot). This produces a magnetic field parallel to the axis of the coil. The actual effective distance must be demonstrated based on the particular part to be examined. For parts longer than these effective distances, the entire length shall be examined by repositioning the part within the coil, allowing for approximately 10 % effective magnetic field overlap. See [6.3.1](#) for field strength methods that can be used in coil magnetization.

6.3.3 *Magnetizing Current Shots*—In a series of magnetizing shots, unless there is an interim demagnetization operation, the amperage value shall proceed from a lower to a higher selection.

6.3.4 *Coil Shots*—The value of the coil shot expressed in ampere-turns (AT) is considered to be the current multiplied by the number of coil turns.

6.3.5 The specimen under test shall have a minimum *L/D* ratio of 2 for proper coil magnetization. Pole pieces may be used to meet this minimum *L/D* ratio of the specimen. See Guide [E709](#) for additional guidance.

#### 6.4 *Particle Application:*

6.4.1 *Wet Magnetic Particle Application, Continuous Method*—Fluorescent particles suspended in a liquid vehicle at the required concentration shall be applied by gently spraying or flowing the suspension over the area to be examined.

6.4.1.1 Proper sequencing and timing of part magnetization and application of particle suspension are required to obtain the proper formation and retention of indications. This requires that the stream of suspension be diverted from the part simultaneously with, or slightly before, energizing the magnetic circuit.

6.4.1.2 The magnetizing current shall be applied for a duration of at least 0.5 second for each application, with a minimum of two shots being used. The second shot shall follow the first while the particles are still mobile on the surface of the part.

6.4.1.3 Under special circumstances, such as the use of automated equipment or for critical parts, the 0.5-second duration and the two-shot requirement may be waived, provided it is demonstrated that the procedure can detect known discontinuities in reference parts.

6.4.1.4 Care shall be exercised to prevent any damage to the part due to overheating or other causes. Weakly held indications on highly finished parts are readily washed away, and care must be exercised to prevent high-velocity flow over critical surfaces. Surfaces to be examined shall not be handled or contacted until the examination is complete.

6.4.1.5 Particle application by continuous immersion shall be used only when specifically approved by the cognizant engineering organization or when it has been documented that it can detect discontinuities or artificial discontinuities in parts under examination.

6.4.2 *Residual Magnetization Method*—In the residual magnetization method, the magnetic particles are applied to the part under examination after the magnetizing force has been discontinued. The residual method is not as sensitive as the continuous method. It can be useful on materials with high retentivity. It is also useful for the examination of parts or areas of parts, which because of geometric constraints, cannot be examined with the continuous method. The residual method shall be used only when specifically approved by the cognizant engineering organization or when it has been documented that it can detect discontinuities



or artificial discontinuities in parts under examination. The test parts shall have the same material and processing steps, and similar geometry, to the actual parts being examined.

6.5 *Evaluation*—Following magnetization, particle application, and before demagnetizing, the parts shall be examined for indications. The minimum acceptable UV-A intensity is  $1000 \mu\text{W}/\text{cm}^2$  at the surface being examined. All indications will be identified as relevant or nonrelevant. Relevant indications will be compared to the proper accept/reject criteria and the parts accepted or rejected accordingly.

6.5.1 *Eye Glasses*—Personnel shall not wear eye glasses that are photochromic (transition lenses) or that have permanently darkened lenses. This is not intended to prohibit the use of eyeglasses with lenses treated to absorb ultraviolet light.

6.5.2 *Dark Adaptation*—Personnel must wait at least 1 min after entering a darkened area for their eyes to adjust to the low-level lighting before performing fluorescent magnetic particle testing.

6.5.3 *Acceptance Requirements*—The acceptance requirements applicable to the part or group of parts shall be incorporated as part of the written procedure either specifically or by reference to other applicable documents containing the necessary information. When parts are zoned, the acceptance criteria for each zone shall be specified.

6.6 *Recording of Indications*—When required by the written procedure, the location of all rejectable indications shall be marked on the part, and permanent records of the location, direction, and frequency of indications may be made by one or more of the following methods:

6.6.1 *Written Description*—By recording the location, length, direction, and number of indications in sketch or tabular form.

6.6.2 *Photography*—By photographing or video recording the indications themselves, the tape, or the strippable film reproduction and placing the photograph in a tabular form along with information giving its location on the part.

6.7 *Post Examination Demagnetization and Cleaning*—All parts shall be demagnetized and cleaned after final examination. Apply corrosion protection as required.

6.7.1 *Demagnetization:*

6.7.1.1 When using AC demagnetization, the part shall be subjected to a field with a peak value greater than, and in nearly the same direction as, the field used during examination. This AC field is then decreased gradually to zero. When using an AC demagnetizing coil, the part is passed through the coil while the current is flowing. For effective demagnetization, parts having complex configurations may require rotating or tumbling while passing through the field of the coil prior to the current being shut off. Repeat this process as necessary.

6.7.1.2 When using DC demagnetization, the initial field shall be higher than, and in nearly the same direction as, the field reached during examination. The field shall then be reversed, decreased in magnitude, and the process repeated (cycled) until an acceptably low value of residual field is reached.

6.7.1.3 Whenever possible, parts that have been magnetized circularly shall be magnetized in the longitudinal direction before being demagnetized. After demagnetization, a calibrated field indicator shall not detect magnetic flux fields with an absolute value above 3 G ( $3 \times 10^{-4}$  T) anywhere on the part.

6.7.2 *Post-examination Cleaning*—Cleaning shall be done with a suitable solvent, air blower, or by other means.

6.7.2.1 Parts shall be examined to ensure that the cleaning procedure has removed magnetic particle residues from holes, crevices, passage ways, etc. Such residue could have an adverse effect on the intended use of the part.

6.7.2.2 Care shall be taken to remove all plugs, masking, or other processing aids that may affect the intended use of the part.

6.7.2.3 Parts shall be protected from corrosion or damage as required.

6.8 *Record of Examination*—Results of all final magnetic particle examinations shall be recorded. All recorded results shall be identified, filed, and made available to the cognizant engineering organization upon request. Records shall provide for traceability

to the specific part or lot inspected. As a minimum, the records shall include: identification of the procedure used, disposition of the examination; identification of the inspector's examination stamp, electronic ID, or signature; and the date of examination. Records shall be kept for a minimum of three years or as otherwise specified in the purchase order or contract.

**6.9 Marking of Accepted Parts**—If specified by the cognizant engineering organization, parts that have been accepted using magnetic particle examination shall be marked in accordance with the applicable drawing, purchase order, contract, or as specified herein prior to leaving the testing facility.

**6.9.1** Marking shall be applied in such a manner and location as to be harmless to the part. The identification shall not be obliterated or smeared by subsequent handling and, when practicable, placed in a location that will be visible after assembly.

**6.9.1.1** When subsequent processing would remove the identification, the applicable marking shall be affixed to the record accompanying the finished parts or assembly.

**6.9.1.2** Bolts and nuts and other fastener products may be identified as having met the requirements of magnetic particle testing by marking each package conspicuously.

**6.9.2 Impression Stamping, Ink Stamping, Laser Marking, Dyeing, Vibro Engraving, or Etching**—Impression stamping, ink stamping, laser marking, dyeing, vibro engraving, or etching may be used when permitted or required by the applicable written procedure, detail specification or drawing, or when the nature of the part is such as to provide for impression stamping of part numbers or other examination personnel markings. Impression stamping shall be located only in the area provided adjacent to the part number or examination personnel's stamp.

**6.9.3 Other Identification**—Other means of identification, such as tagging, may be used for parts that have a configuration or function precluding the use of stamping, vibro engraving, or etching, as in the case of completely ground or polished balls, rollers, pins, or bushings.

**6.10 Identifying Symbols and Color Markings:**

**6.10.1 One-Hundred Percent Examination**—When items are examined and accepted by 100 % examination, each item shall be marked as follows:

**6.10.1.1 Dyeing**—When dyeing is applicable, a dye of acceptable adherence which is predominantly blue (in accordance with SAE AMS-STD-595) shall be employed. However, if a color conflict is incurred with any other method, magnetic particle examination may be indicated by two adjacent blue dots or other suitable means.

**6.10.1.2 Stamping, Laser Marking, Vibro Engraving, or Etching**—When impression stamping or ink stamping, laser marking, vibro engraving, or etching is used to mark 100 % examined parts, the letter “M” with a circle around it shall be employed.

**6.10.2 Marking Accepted Lots**—When items are accepted by means of a sampling procedure, each item of an accepted lot shall be marked as follows:

**6.10.2.1 Dyeing**—When dyeing is applicable, a dye of acceptable adherence that is predominantly orange (in accordance with SAE AMS-STD-595) shall be employed.

**6.10.2.2 Stamping, Laser Marking, Vibro Engraving, or Etching**—When impression stamping, vibro engraving, or etching is used to mark lot examined parts, the letter “M”, without a circle around it, shall be employed.

## **7. Quality Control**

**7.1 System Performance Verification**—The overall performance of the magnetic particle testing system, including the equipment, materials, and the lighting environment being used, shall be verified initially and at regular intervals thereafter. The required verification intervals are stated in **Table 1**. Records of the verification results shall be maintained and retained for the time period specified in the contract. Establish a system in accordance with ANSI/NCSL Z540.3, or ISO 10012, or ISO/IEC 17025 for calibration and certification of all current and voltage measuring devices, ammeter shunts, timers, illuminance photometers, radiometers, gaussmeters, and field indicators used in verification.

**7.1.1 Use of Test Parts with Discontinuities**—A reliable method for system performance verification is the use of representative

reference parts containing discontinuities of the type, location, and size specified in the acceptance requirements and examined in accordance with a written procedure. If correct magnetic particle indications can be produced and identified in these representative parts, the overall system performance is verified. Parts used for verification will be demagnetized, cleaned thoroughly following the examination, and checked under UV-A or visible light, as appropriate to the examination process, to ensure that residual indications do not remain.

**7.1.2 Fabricated Test Parts with Artificial Discontinuities**—When actual production parts with known discontinuities of the type, location, and size needed for verification are not available or are impractical, fabricated test or production parts with artificial discontinuities or a ring specimen similar to the ring in **Annex A3** may be used. Artificial discontinuities may be fabricated to meet a particular need or may be commercially available magnetic field indicators or shims as shown in **Annex A2**. All applicable conditions for the use of such reference parts, as described in **7.1.1**, shall apply.

**7.2 Suspension Vehicle Tests** (Not required for aerosol can suspensions):

**7.2.1 Concentration/Contamination Tests**—Particle concentration and contamination shall be determined upon start up, at regular intervals thereafter, and whenever the bath is changed or adjusted. The required testing intervals are stated in **Table 1**.

**7.2.1.1 Determination of Wet Particle Concentration**—Agitate the particle suspension a minimum of 30 min to ensure uniform distribution of particles throughout the bath. Place a 100 mL sample of the agitated suspension in a pear-shaped centrifuge tube with a graduated stem in 0.05 mL increments for fluorescence baths. (Centrifuge tubes shall be as specified in Guide **E709**.) Demagnetize the sample and allow the tube to stand undisturbed for a settling time of at least 60 min if using petroleum distillate or at least 30 min for conditioned water suspension. Read the volume of settled particles. If the concentration is out of the tolerance stated in the written procedure add particles or suspension vehicle, as required, and re-determine the particle concentration. If the settled particles appear to be loose agglomerates rather than a solid layer, repeat the process with a second sample. If the second sample also appears agglomerated, replace the entire bath suspension. Thirty-minute settling times (for oil suspensions), or other accelerated tests, may be used if they have been verified to give results equivalent to the procedure described in this clause.

**7.2.1.2 Determination of Wet Particle Contamination**—Perform the tests specified in **7.2.1.1**. Independently examine the graduated portion of the tube, under both UV-A and visible light, for striations or bands which are different in color or appearance. Bands or striations may indicate contamination. If the total volume of the contaminants, including bands or striations, exceeds 30 % of the total settled volume of magnetic particles and the contaminants, the bath must be adjusted or replaced. Clouding or fluorescence of the vehicle to the extent that the markings on the centrifuge tube, which are between 5 ml and 25 ml, cannot be seen when viewed through the vehicle indicate the bath must be replaced before further use.

<https://standards.iteh.ai/catalog/standards/sist/cdbddc66-2c65-4278-8105-a064fe042fbf/astm-e1444-e1444m-22a>

**7.2.2 Water Break Test**—In this test of water-based vehicles, a clean part with a surface finish the same as the parts to be examined or an actual production part is flooded with the conditioned water, and the appearance of the surface is noted after flooding is stopped. Sufficient wetting agent is present if a continuous even film forms over the entire part. If the film of suspension breaks, exposing bare surface, insufficient wetting agent is present, or the part has not been cleaned adequately. For adequacy, this visual observation shall be performed individually under both visible light and UV-A conditions as applicable.

**7.2.3 Determination of Particle Sensitivity**—For guidance using particle performance evaluation devices, see Guide **E709** or Practice **E3024/E3024M**.

**7.3 Lighting:**

**7.3.1 Visible Light**—Conduct visible light intensity measurements upon initial light installation, or when changes occur that would cause the light intensity to change and at the intervals specified in **Table 1**.

**7.3.1.1** Visible light may be used in assisting with interpretation of indications found with fluorescent magnetic particles. A minimum light intensity of 100 fc [1076 lx] shall be available at the surface of the part undergoing examination or evaluation.

**7.3.1.2 Ambient Visible Light**—Fluorescent magnetic particle examinations shall be performed in a darkened area with a maximum ambient visible light level of 2 fc [21.5 lx] measured at the part surface.

NOTE 3—Neither the visible light emission from the UV-A lamp, or the fluorescent response of the particles are to be included in the ambient light measurement.