



Designation: **D635—18** **D635 – 22**

Standard Test Method for Rate of Burning and/or Extent and Time of Burning of Plastics in a Horizontal Position¹

This standard is issued under the fixed designation D635; the number immediately following the designation indicates the year of original adoption or, in the case of revision, the year of last revision. A number in parentheses indicates the year of last reappraisal. A superscript epsilon (ϵ) indicates an editorial change since the last revision or reappraisal.

This standard has been approved for use by agencies of the U.S. Department of Defense.

1. Scope*

1.1 This fire-test-response test method covers a small-scale laboratory screening procedure for comparing the relative linear rate of burning or extent and time of burning, or both, of plastics in the form of bars, molded or cut from sheets, plates, or panels, and tested in the horizontal position.

NOTE 1—This test method, and test method A of IEC 60695-11-10 are technically equivalent.

NOTE 2—For additional information on materials which do not burn to the first reference mark by this test, see Test Method **D3801**.

1.2 This test method was developed for polymeric materials used for parts in devices and appliances. The results are intended to serve as a preliminary indication of their acceptability with respect to flammability for a particular application. The final acceptance of the material is dependent upon its use in complete equipment that conforms with the standard applicable to such equipment.

1.3 The classification system described in **Appendix X1** is intended for quality assurance and the preselection of component materials for products.

1.4 The values stated in SI units are to be regarded as standard. No other units of measurement are included in this standard.

1.5 *This standard is used to measure and describe the response of materials, products, or assemblies to heat and flame under controlled conditions, but does not by itself incorporate all factors required for fire hazards or fire risk assessment of materials, products, or assemblies under actual fire conditions.*

1.6 *This standard does not purport to address all of the safety concerns, if any, associated with its use. It is the responsibility of the user of this standard to establish appropriate safety, health, and environmental practices and determine the applicability of regulatory limitations prior to use. For specific hazards statements, see 9.2.*

1.7 *This international standard was developed in accordance with internationally recognized principles on standardization established in the Decision on Principles for the Development of International Standards, Guides and Recommendations issued by the World Trade Organization Technical Barriers to Trade (TBT) Committee.*

¹ This test method is under the jurisdiction of ASTM Committee **D20** on Plastics and is the direct responsibility of Subcommittee **D20.30** on Thermal Properties (Section D20.30.03).

Current edition approved Nov. 1, 2018; July 1, 2022. Published November 2018; July 2022. Originally approved in 1941. Last previous edition approved in 2014 as **D635 – 14**; **D635 – 18**. DOI: [10.1520/D0635-18](https://doi.org/10.1520/D0635-18); [10.1520/D0635-22](https://doi.org/10.1520/D0635-22).

***A Summary of Changes section appears at the end of this standard**

2. Referenced Documents

2.1 *ASTM Standards:*²

D618 Practice for Conditioning Plastics for Testing

D648 Test Method for Deflection Temperature of Plastics Under Flexural Load in the Edgewise Position

D883 Terminology Relating to Plastics

D1929 Test Method for Determining Ignition Temperature of Plastics

D2843 Test Method for Density of Smoke from the Burning or Decomposition of Plastics

D3801 Test Method for Measuring the Comparative Burning Characteristics of Solid Plastics in a Vertical Position

D5025 Specification for Laboratory Burner Used for Small-Scale Burning Tests on Plastic Materials

D5207 Practice for Confirmation of 20-mm (50-W) and 125-mm (500-W) Test Flames for Small-Scale Burning Tests on Plastic Materials

E84 Test Method for Surface Burning Characteristics of Building Materials

E176 Terminology of Fire Standards

E456 Terminology Relating to Quality and Statistics

E691 Practice for Conducting an Interlaboratory Study to Determine the Precision of a Test Method

E2935 Practice for Evaluating Equivalence of Two Testing Processes

2.2 *IEC Standards:*³

IEC 60695-11-10 Fire Hazard Testing—Part 11-10 Test Flames—50W Horizontal and Vertical Flame Test Methods

2.3 *ICC Codes:*⁴

IBC International Building Code (2018)(2024)

3. Terminology

3.1 *Definitions:*

3.1.1 Terms used in this test method are in accordance with the definitions in Terminology D883, unless otherwise specified. For terms relating to fire, the terms used in this test method are in accordance with the definitions in Terminology E176. For terms relating to precision and bias and associated issues, the terms used in this test method are in accordance with the definitions in Terminology E456.

4. Summary of Test Method

4.1 A bar specimen of the material to be tested is supported horizontally at one end. The free end is exposed to a specified gas flame for 30 s. Time and extent of burning are measured and reported if the specimen does not burn 100 mm. An average burning rate is reported for a material if it burns to the 100 mm mark from the ignited end.

5. Significance and Use

5.1 Tests made on a material under conditions herein prescribed are of value in comparing the rate of burning or extent and time of burning characteristics, or both, of different materials, in controlling manufacturing processes, or as a measure of deterioration or change in these burning characteristics prior to or during use. Correlation with flammability under actual use conditions is not implied.

5.2 The rate of burning and other burning phenomena will be affected by such factors as density, pigments, any anisotropy of the material and the thickness of the specimen. Test data shall be compared only for specimens of similar thickness, whether comparisons are being made with the same or different materials. The rate of burning and other burning phenomena will vary with thickness.

5.3 It is feasible that sheet materials that have been stretched during processing will relax during burning and give erratic results unless they are first heated above their deflection temperature, in accordance with Test Method D648, for a time sufficient to permit complete relaxation.

² For referenced ASTM standards, visit the ASTM website, www.astm.org, or contact ASTM Customer Service at service@astm.org. For *Annual Book of ASTM Standards* volume information, refer to the standard's Document Summary page on the ASTM website.

³ Publications of the International Electrotechnical Commission (IEC) and International Organization for Standardization (ISO) are available from American National Standards Institute (ANSI), 25 W. 43rd St., 4th Floor, New York, NY 10036.

⁴ Available from International Code Council (ICC), 500 New Jersey Ave., NW, 6th Floor, Washington, DC 20001, <http://www.iccsafe.org>.

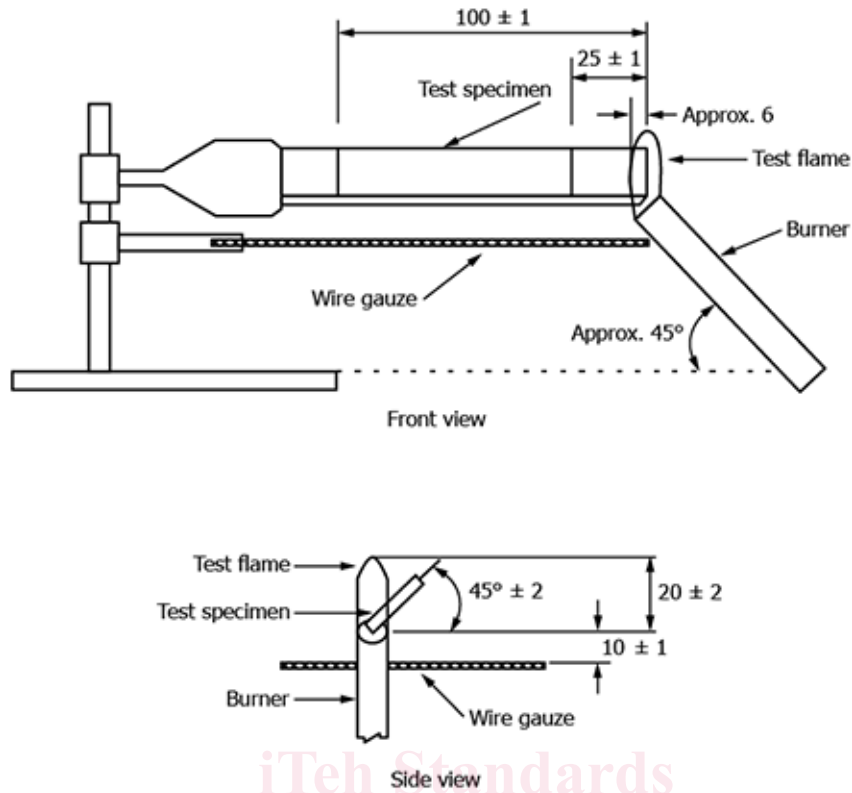

FIG. 1 Test Fixture

Dimensions in millimeters

5.4 Burning tests require that certain variables be arbitrarily fixed, for example, specimen size, energy source and application time, and end points. Materials will be found that are unusually sensitive to one or more of the conditions chosen for this method leading to highly variable results. Additional burning characterization by other methods is highly desirable in such cases (see Note 2).

5.5 In this procedure, the specimens are subjected to specific laboratory test conditions. If different test conditions are substituted or the end-use conditions are changed, it will not always be possible by or from this test to predict changes in the fire-test-response characteristics measured. Therefore, the results are valid only for the fire-test-exposure conditions described in this procedure.

6. Apparatus

6.1 *Test Chamber*, enclosed laboratory hood, or chamber free of induced or forced draft during test, having an inside volume of at least 0.5 m³. An enclosed laboratory hood with a heat-resistant glass window for observing the test and an exhaust fan for removing the products of combustion after the tests is recommended. The atmosphere in and around the test chamber shall be maintained between 15 to 35°C and ≤75 % relative humidity.

NOTE 3—The amount of oxygen available to support combustion is naturally important for the conduct of these fire-test-response tests. For tests conducted by this test method when burning times are protracted, chamber sizes less than 1 m³ may not provide accurate results.

NOTE 4—Some laboratory hoods have induced drafts even with the exhaust fan off. A positive-closing damper is recommended.

NOTE 5—A mirror in the chamber, to provide a rear view of the specimen, has been found useful in some enclosures.

6.2 *Test Fixture*, A laboratory ring stand or test fixture equipped with a means of holding a 125 mm² wire gauze horizontal and a small clamp permitting the specimen to be held with its longitudinal axis horizontal and its transverse axis inclined at 45 ± 2° angle as illustrated in Fig. 1.

NOTE 6—A pan of water may be placed on the floor of the hood in position to catch any burning particles that may drop during the test.

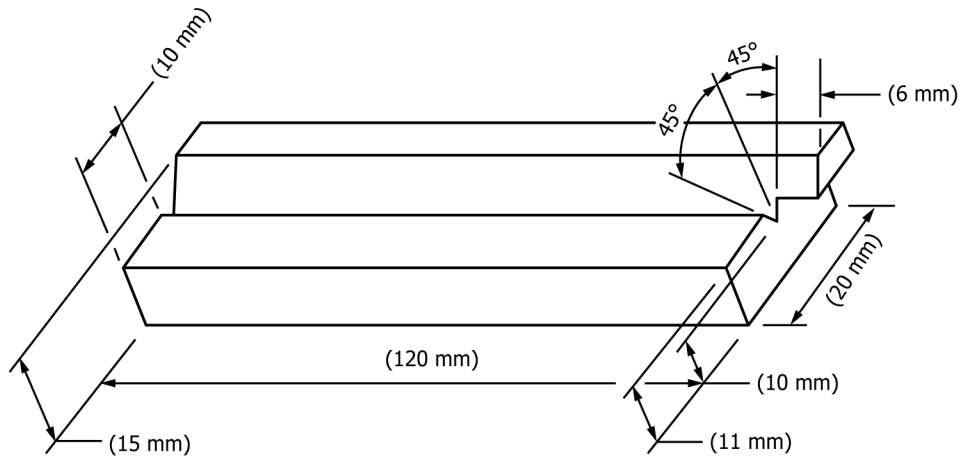

FIG. 2 Flexible Specimen Support Fixture

6.3 *Laboratory Burner*, constructed in accordance with Specification [D5025](#).

6.4 *Gas Supply*, a supply of technical-grade methane gas with suitable regulator and meter for uniform gas flow. Natural gas mixtures having an energy density of approximately 37 MJ/m³ have been found to provide similar results. However, technical-grade methane gas shall be used as the referee in cases of dispute.

6.5 *Wire Gauze*, 20-mesh (approximately 20 openings per 25 mm), made with 0.43 ± 0.03 mm diameter iron wire cut to approximately 125 mm², to sustain burning or glowing particles falling from the specimens.

6.6 *Timing Device*, accurate to 0.5 s.

6.7 *Scale*, graduated in millimeters.

6.8 *Micrometer*, accurate to 0.05 mm.

6.9 *Conditioning Room or Chamber*, capable of being maintained at 23 ± 2°C and 50 ± 10 % relative humidity.

6.10 *Flexible Specimen Support Fixture*, used to facilitate the testing of specimens that sag and touch the wire gauze. (See [9.4](#) and [Fig. 2](#).)

7. Test Specimens

7.1 All test specimens shall be cut from a representative sample of the material (sheet or end products), or shall be cast or injection-, compression-, transfer- or pultrusion-molded to the necessary form. After any cutting operation, care shall be taken to remove all dust and any particles from the surface; cut edges shall be fine sanded to have a smooth finish. Unless otherwise agreed, fabrication of test specimens shall be in accordance with the specifications of the material being tested.

7.2 Specimens shall be 125 ± 5 mm long by 13.0 ± 0.5 mm wide, and provided in the minimum thickness and in the 3.0 (−0.0 +0.2) mm thickness. The 3.0 mm thick specimens are not necessary if the minimum thickness is greater than 3.0 mm, or the maximum thickness is less than 3.0 mm. The maximum thickness shall not exceed 13 mm. The maximum width shall not exceed 13.5 mm. The edges shall be smooth, and the radius on the corners shall not exceed 1.3 mm.

7.3 It is possible that the results of tests carried out on test specimens of different colors, thicknesses, densities, molecular masses, directions of anisotropy and types, or with different additives, fillers/reinforcements will be different.

7.3.1 Test specimens in the minimum and maximum densities, melt flows and level of fillers/reinforcements contents shall be considered representative of the range, if the results yield the same flame test classification. If the burning characteristics are not

essentially the same for all specimens representing the range, the evaluation is to be limited only to the materials in the densities, melt flows, and fillers/reinforcements contents tested. Additional specimens in the intermediate densities, melt flows, and fillers/reinforcements contents are to be tested.

7.3.2 Uncolored test specimens and test specimens with the highest level of organic and inorganic pigment loading by weight are considered representative of the color range, if the test results are essentially the same. When certain pigments are known to affect flammability characteristics, they are also to be tested. Specimens to be tested are those that:

- (a) contain no coloring
- (b) contain the highest level of organic pigments
- (c) contain the highest level of inorganic pigments
- (d) contain pigments which are known to adversely affect flammability characteristics

8. Conditioning

8.1 Condition ten bar specimens for each material and thickness to be tested in accordance with Procedure A of Practice **D618** for a minimum of 48 hours. Once removed from the conditioning atmosphere test the specimens within 1 h. Temperature and humidity tolerances shall be in accordance with Section 7 of Practice **D618**.

8.2 Conduct testing in a laboratory atmosphere of 15 to 35°C and $\leq 75\%$ relative humidity.

9. Procedure

9.1 Prepare at least ten bar specimens. After measuring and recording the specimen thickness, mark each specimen with two lines perpendicular to the longitudinal axis of the bar, 25 ± 1 and 100 ± 1 mm from the end that is to be ignited.

9.2 Conduct the burning test in a chamber, enclosure, or laboratory hood free of induced or forced draft. (**Warning**—Products of combustion are potentially toxic. An enclosed laboratory hood and an exhaust fan for removing the products of combustion after the tests are recommended. The exhaust fan is turned off during the test and turned on immediately following the test in order to remove products of combustion.)

9.3 Clamp the specimen at the end farthest from the 25 mm reference mark, in a support with its longitudinal axis horizontal and its transverse axis inclined at $45 \pm 2^\circ$ as illustrated in **Fig. 1**. Clamp the wire gauze horizontally beneath the specimen, with a distance of 10 ± 1 mm between the lowest edge of the specimen and the wire gauze, and with the free end of the specimen even with the edge of the gauze. Any material remaining on the wire gauze from the previous test must be burned off or a new section of wire gauze used for each test.

9.4 If the specimen sags at its free end during the initial set up and is not able to maintain the distance of 10 ± 1 mm as specified in **9.2**, the flexible specimen support fixture illustrated in **Fig. 2** shall be used. Position the support fixture under the specimen with the small extending portion of the support fixture at least 20 mm from the free end of the specimen. Provide enough clearance at the clamped end of the specimen so that the support fixture can be moved freely sideways. As the flame front progresses along the specimen, withdraw the support fixture at the same approximate rate, preventing the flame front from contacting the flexible specimen support fixture, so that there is no effect on the test flame or on the burning of the specimen.

9.5 With the central axis of the burner tube in the vertical position, place the burner remote from the specimen, ignite, and adjust it to produce a blue flame 20 mm high. Adjust the gas supply and the air ports of the burner until a 20-mm yellow-tipped blue flame is produced, and then increase the air supply until the yellow tip just disappears. Measure the height of the flame. If the flame height is not 20 ± 2 mm, adjust the burner gas supply to give the proper flame height. Once the flame has been properly set to a height of 20 ± 2 mm wait for at least 5 min to allow the burner conditions to reach equilibrium.

NOTE 7—See Practice **D5207** for recommended back pressure and flow rate for the gas supply and calibration procedure for the 20 mm flame.

9.6 Place the burner so that the test flame impinges on the free end of the test specimen to a depth of approximately 6 mm starting the timing device simultaneously. The central axis of the burner tube is to be in the same vertical plane as the longitudinal bottom edge of the specimen and inclined toward the end of the specimen at an angle of approximately 45 ± 2 degrees to the horizontal. See **Fig. 1**. Apply the flame for 30 ± 1 s without changing its position. If the test specimen shrinks from the applied flame without ignition, the material is not suitable for evaluation by these test methods. Excessive distortion of the specimen during the test will

invalidate the results. Withdraw the test flame sufficiently from the specimen (see **Note 8**) so that there is no effect on the specimen after 30 ± 1 s or as soon as the flame front of the specimen reaches the 25 mm mark (if less than 30 s). Restart the timing device when the flame front reaches the 25 mm reference mark.

NOTE 8—Withdrawing the burner a distance of 150 mm from the specimen has been found satisfactory.

9.7 If the specimen continues to burn, with a flame or glowing combustion (visible glow without flame), after removal of the test flame, record the elapsed time (t), in seconds, for the flame front to travel from the 25 mm reference mark to the 100 mm reference mark and record the burned length (L), as 75 mm. If the flame front passes the 25 mm reference mark but does not reach the 100 mm reference mark, record the elapsed time (t), in seconds, and the burned length (L), in millimeters between the 25 mm reference mark and where the flame front stopped.

9.8 Repeat the test procedure (9.1 – 9.7) until three specimens have burned to or beyond the 100 mm reference mark, or ten specimens have been tested.

NOTE 9—For classification purposes, if only one specimen does not comply with the criteria, test an additional set of specimens. See **X1.3**.

10. Calculation

10.1 Calculate the linear burning rate (V), in millimeters per minute, for each specimen where the flame front reaches the 100 mm reference mark using the equation:

$$V = 60L/t$$

where:

L = the burned length, in millimeters, as defined in 9.7; and

t = the time, in seconds, as defined in 9.7.

NOTE 10—If the flame front reached the 100-mm reference mark, $L = 75$.

NOTE 11—The SI units of the linear burning rate is meter per second. In practice, the unit millimeter per minute is used.

NOTE 12—It is acceptable to report the results in cm/min by using the method prescribed in 10.1 and then dividing the obtained rate by ten.

10.2 Calculate the average linear burning rate or classify the material in accordance with the appendix.

11. Report

11.1 Include the following in the complete report:

11.1.1 *Material Identification*—Include generic description, manufacturer, commercial designation, lot number, and color.

11.1.2 The thickness, as measured with a micrometer to the nearest 0.1 mm, of the test specimen.

11.1.3 The nominal apparent density (rigid cellular materials only).

11.1.4 The direction of any anisotropy relative to the test specimen dimensions.

11.1.5 Conditioning treatment.

11.1.6 Any prior treatment before testing, other than cutting, trimming and conditioning.

11.1.7 Whether or not the specimen continued to burn (with or without visible flame) after application of test flame.

11.1.8 Whether or not the flame front reached the 25 and 100 mm reference marks.

11.1.9 For specimens with which the flame front does not reach or pass the 25 mm reference mark, a statement that indicates the flame front did not reach or pass the 25 mm reference mark. Do not report an elapsed time (t) and burned length (L).

TABLE 1 Average Linear Burning Rate for Specimens Tested without Flexible Specimen Support Fixture

Material	Rate of Linear Burning, mm/min					
	Nominal Specimen Thickness, mm	Average	S_r^A	S_R^B	r^C	R^D
Polyethylene (PE)	3.0	15.2	0.7	1.3	1.9	3.7
ABS	3.2	27.9	2.1	4.1	5.7	11.5
Acrylic	3.0	29.7	1.7	2.2	4.9	6.1

^A S_r is the within-laboratory standard deviation for the indicated material. It is obtained by pooling the within-laboratory standard deviations of the test results from all of the participating laboratories:

$$S_r = [((s_1)^2 + (s_2)^2 \dots + (s_n)^2)/n]^{1/2}$$

^B S_R is the between-laboratories reproducibility, expressed as stated deviation:

$$S_R = [S_r^2 + S_L^2]^{1/2}$$

where: S_L = the standard deviation of laboratory means.

^C r is the within-laboratory critical interval between two test results = $2.8 \times S_r$.

^D R is the between-laboratories critical interval between two test results = $2.8 \times S_R$.

TABLE 2 Average Linear Burning Rate for Specimens Tested with Flexible Specimen Support Fixture

Material	Rate of Linear Burning, mm/min					
	Nominal Specimen Thickness, mm	Average	S_r^A	S_R^B	r^C	R^D
Polyurethane (PUR)	1.3	41.6	1.0	^E	2.9	^E
Polyurethane (PUR)	0.8	60.9	10.9	14.4	30.6	40.4
Polyurethane (PUR)	0.4	82.3	10.6	26.6	29.8	74.4
Polyethylene terephthalate (PET)	0.1	192.0	32.2	^E	123.7	^E

^A S_r = within-laboratory standard deviation for the indicated material. It is obtained by pooling the within-laboratory standard deviations of the test results from all of the participating laboratories, as follows:

$$S_r = [((s_1)^2 + (s_2)^2 \dots + (s_n)^2)/n]^{1/2}$$

^B S_R = between-laboratories reproducibility, expressed as stated deviation, as follows:

$$S_R = [S_r^2 + S_L^2]^{1/2}$$

where S_L = the standard deviation of laboratory means.

^C r = within-laboratory critical interval between two test results = $2.8 \times S_r$.

^D R = between-laboratories critical interval between two test results = $2.8 \times S_R$.

^E The number of laboratories in the interlaboratory study reporting a linear burning rate was too small to establish a between-laboratory standard deviation.

11.1.10 For specimens with which the flame front passed the 25 mm reference mark but did not reach the 100 mm reference mark, the elapsed time (t) and burned length (L).

11.1.11 If a specimen does not burn to the 100 mm mark because of dripping, flowing, or falling burning particles, the report must so indicate.

11.1.12 If a specimen is reignited by burning material on the gauze, the report must so state.

11.1.13 For specimens with which the flame front reached the 100 mm reference mark, the average linear burning rate, (V).

11.1.14 Whether the flexible specimen support fixture was used.

11.1.15 The caveat contained in 1.5 herein shall be incorporated in its entirety in the test report issued.

11.1.16 *Optional*—Flame classification as determined from the appendix.