



Designation: ~~D6241~~—14 D6241 – 22

## Standard Test Method for Static Puncture Index Strength of Geotextiles and Geotextile-Related Products Using a 50-mm 50 mm Probe<sup>1</sup>

This standard is issued under the fixed designation D6241; the number immediately following the designation indicates the year of original adoption or, in the case of revision, the year of last revision. A number in parentheses indicates the year of last reappraisal. A superscript epsilon ( $\epsilon$ ) indicates an editorial change since the last revision or reappraisal.

### 1. Scope

1.1 This test method is an index test used to measure the force required to puncture a geotextile and geotextile-related products. ~~The relatively large size of the plunger provides~~ products with a 50 mm diameter probe rod. The dimensions of the probe provide a multidirectional force on the geotextile.

1.2 The values stated in SI units are to be regarded as the standard. The values given in parentheses are for information only.

1.3 *This standard does not purport to address all of the safety concerns, if any, associated with its use. It is the responsibility of the user of this standard to establish appropriate ~~safety~~ safety, health, and ~~health~~ environmental practices and determine the applicability of regulatory limitations prior to use.*

1.4 *This international standard was developed in accordance with internationally recognized principles on standardization established in the Decision on Principles for the Development of International Standards, Guides and Recommendations issued by the World Trade Organization Technical Barriers to Trade (TBT) Committee.*

### 2. Referenced Documents

#### 2.1 ASTM Standards:<sup>2</sup>

[D76/D76M](#) Specification for Tensile Testing Machines for Textiles

[D123](#) Terminology Relating to Textiles

~~D1776~~ [D1776/D1776M](#) Practice for Conditioning and Testing Textiles

[D1883](#) Test Method for California Bearing Ratio (CBR) of Laboratory-Compacted Soils

[D4354](#) Practice for Sampling of Geosynthetics and Rolled Erosion Control Products (RECPs) for Testing

[D4439](#) Terminology for Geosynthetics

[E691](#) Practice for Conducting an Interlaboratory Study to Determine the Precision of a Test Method

NOTE 1—Test Method [D1883](#) describes a mold (CBR mold) that can be used for this test method.

### 3. Terminology

3.1 *Definitions*—For definitions of other textile terms used in this test method, refer to Terminology [D123](#). For definitions of other terms relating to geosynthetics used in this test method, refer to Terminology [D4439](#).

#### 3.2 *Definitions of Terms Specific to This Standard:*

<sup>1</sup> This test method is under the jurisdiction of ASTM Committee [D35](#) on Geosynthetics is the direct responsibility of Subcommittee [D35.01](#) on Mechanical Properties. Current edition approved July 1, 2014/July 1, 2022. Published July 2014/July 2022. Originally approved in 1998. Last previous edition approved in 2009/2014 as ~~D6241—04~~ [D6241—14](#). (2009)<sup>ε1</sup>; DOI: 10.1520/D6241-14.10.1520/D6241-22.

<sup>2</sup> For referenced ASTM standards, visit the ASTM website, www.astm.org, or contact ASTM Customer Service at service@astm.org. For *Annual Book of ASTM Standards* volume information, refer to the standard's Document Summary page on the ASTM website.

~~3.2.1 atmosphere for testing geotextiles, n—air maintained at a relative humidity of 50 to 70 % and a temperature of  $21 \pm 2^{\circ}\text{C}$  ( $70 \pm 4^{\circ}\text{F}$ ).~~

~~3.2.2 geotextile, n—a permeable geosynthetic composed solely of textiles.~~

~~3.2.3 puncture resistance, n—the inherent resisting mechanism of the test specimen to the failure by a penetrating or puncturing object.~~

#### 4. Summary of Test Method

4.1 A test specimen is clamped without tension between circular plates and secured in a tensile or compression testing machine, or both. A force is exerted against the center of the unsupported portion of the test specimen by a circular steel plunger probe attached to the load indicator until rupture occurs. The maximum force is the value of puncture strength.

#### 5. Significance and Use

~~5.1 This test method for determining the puncture strength of geotextiles is to be used by the industry as an index of puncture strength. The use of this test method is to establish an index value by providing standard criteria and a basis for uniform reporting. Puncture using a 50 mm flat circular probe is applicable to determine the index strength resistance and deformation of a particular geotextile or geotextile-related products.~~

5.2 This test method is considered satisfactory for acceptance testing of commercial shipments of geotextiles.

5.3 In case of a dispute arising from differences in reported test results when using this test method for acceptance testing of commercial shipments, the purchaser and the supplier should conduct comparative tests to determine if there is a statistical bias between their laboratories. Competent statistical assistance is recommended for the investigation of bias. As a minimum, the two parties should take a group of test specimens that are as homogeneous as possible and that are from a lot of the type in question. The test specimens then should be randomly assigned in equal numbers to each laboratory for testing. The average results from the two laboratories should be compared using Student's t-test for unpaired data and an acceptable probability level chosen by the two parties before the testing is begun. If a bias is found, either its cause must be found and corrected, or the purchaser and the supplier must agree to interpret future test results in the light of the known bias.

5.4 This test method is not applicable to materials that are manufactured in sizes that are too small to be placed into the test apparatus in accordance with the procedures in this test method. Furthermore, it is not appropriate to separate plies of a geosynthetic or geocomposite for use in this test method.

#### 6. Apparatus

~~6.1 Testing Machine, Machine—must be constant-rate-of-extension (CRE) type. Types of tensile machines covered in this specification are constant-rate-of-extension, constant-rate-of-traverse, and constant-rate-of-loading types, with autographic recorder conforming to the requirement of Specification D76/D76M.~~

6.2 Plunger, Probe—A circular, 150 mm long polished steel loading platen with a flat diameter of  $50 \pm 1$  mm with a radial edge of  $2.5 \pm 0.5$  mm. See Fig. 1.

6.3 Clamping Apparatus, consisting of concentric plates with an internal diameter of 150 mm (5.9 in.), capable of clamping the test specimen without slippage (limit slippage of test specimen to 5 mm). The external diameter is suggested to be 250 mm (9.8 in.). The diameter of the holes used for securing the ring clamp assemblage is suggested to be 11 mm (7/16 in.) and equally spaced at a diameter of 220 mm (8.7 in.). The surfaces of these plates can consist of serrated plates, grooves with rubber O-rings, or coarse sandpaper bonded onto opposing surfaces. It is suggested that 9.5 mm (3/8 in.) bolts be welded to the bottom plate so that the top plate can be placed over the bolts and nuts and easily tightened. A guide block may be used to help seat the material being clamped. Other clamps that eliminate slippage are acceptable. See Fig. 2, Figs. 2 and 3, and Fig. 3.

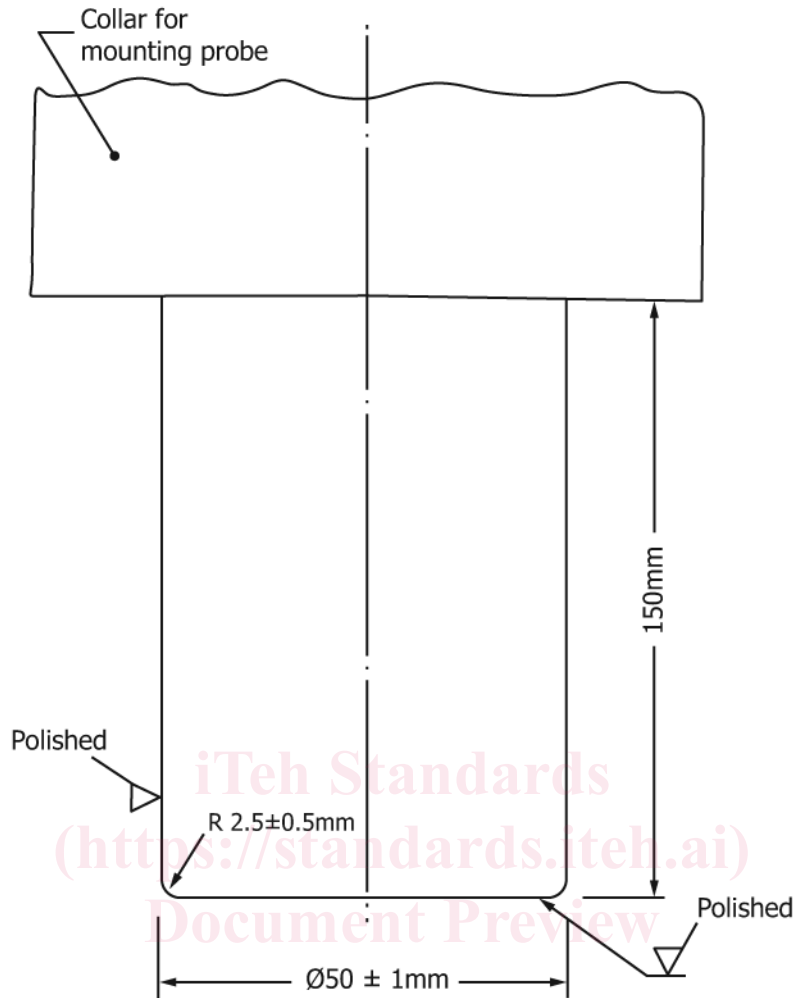

NOTE 1—All dimensions are in millimetres.

NOTE 2—This diagram is not to scale.

FIG. 1 Plunger Probe

## 7. Sampling and Selection of Specimens

7.1 *Lot Sample*—In the absence of other guidelines, divide the product into lots and take lot samples as specified in Practice D4354.

7.2 *Laboratory Sample*—Consider the units in the lot sample as the units in the laboratory sample. For the laboratory sample, take a full-width-full-width sample of sufficient length along the selvage or edge of the roll so that the requirements of 7.37.3 – 7.5.2 through 7.5.2 can be met. Exclude the inner and outer wraps of the roll or any material containing folds, crushed areas, or other distortions not representative of the sample lot.

7.3 Remove test specimens from the laboratory sample in a randomly distributed pattern across the width with no specimen taken nearer the selvage of fabric edge than 1/20 of the fabric width or 150 mm (6 in.), whichever is the smaller, unless otherwise specified.

7.4 *Test Specimens*—From each unit in the laboratory sample, cut the specimens so that the edge of specimen will extend beyond the edge of the clamp by 10 mm (0.39 in.) in all directions.

7.5 *Number of Specimens*—Unless otherwise agreed upon, as when provided in an applicable material specification, take a number

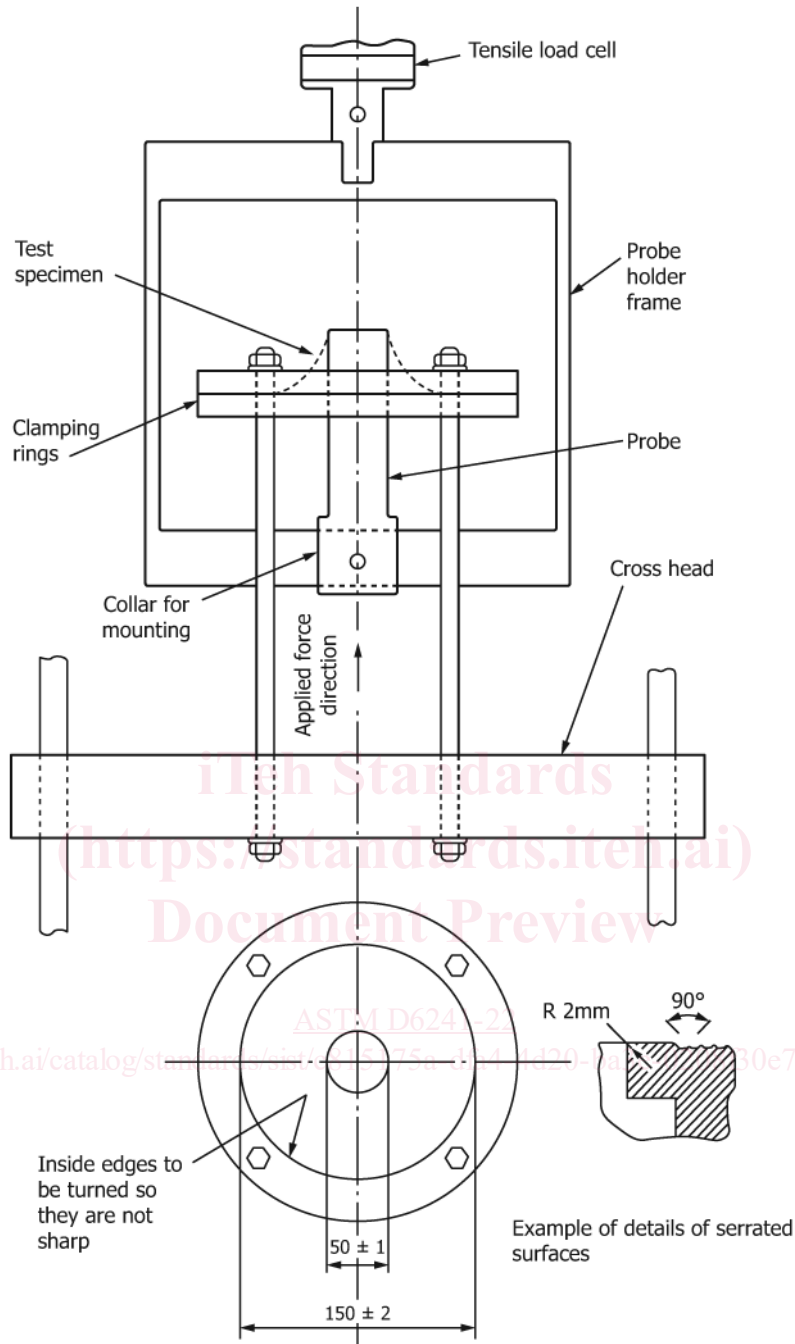

NOTE 1—All dimensions are in millimetres.

NOTE 2—This diagram is not to scale.

FIG. 2 Typical Arrangement for Test on Tensile Testing Machine (Method A)

of test specimens per laboratory sample such that the user may expect at the 95 % probability level that the test result is not more than 5.0 % of the average above or below the true average of the sample. Determine the number of specimens per sample as follows:

7.5.1 *Reliable Estimate of  $v$* —When there is a reliable estimate of  $v$  based upon extensive past records for similar materials tested in the user’s laboratory as directed in this test method, calculate the required number of specimens as follows:

$$n = (tv/A)^2 \tag{1}$$

$$n = (tv/A)^2 \tag{1}$$

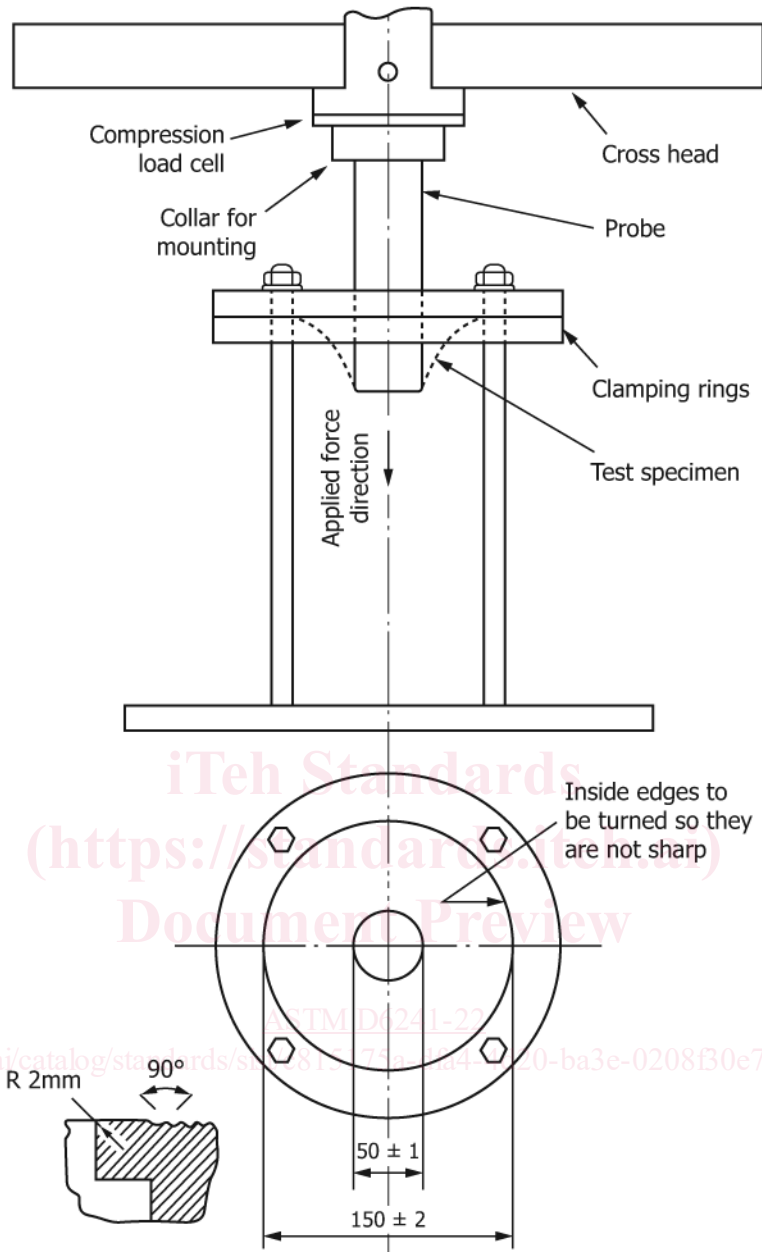

Example of details of serrated surfaces

NOTE 1—All dimensions are in millimetres.  
 NOTE 2—The diagram is not to scale.

FIG. 3 Typical Arrangement for Test on Compression Testing Machine (Method B)

where:

- $n$  = number of test specimens (rounded upward to a whole number),
- $v$  = reliable estimate of the coefficient of variation for individual observations on similar materials in the user's laboratory under conditions of single-operation precision, %,
- $t$  = the value of Student's  $t$  one-sided limits, a 95 % probability level, and the degrees of freedom, associated with the estimate of  $v$ , and
- $t$  = the value of Student's  $t$  one-sided limits, a 95 % probability level, and the degrees of freedom associated with the estimate of  $v$ , and
- $A$  = 5.0 % of the average, the value of the allowable variation.

7.5.2 No Reliable Estimate of  $v$ —When there is no reliable estimate of  $v$  for the user's laboratory, the equation given in 7.5.1