INTERNATIONAL STANDARD



5289

INTERNATIONAL ORGANIZATION FOR STANDARDIZATION • МЕЖДУНАРОДНАЯ ОРГАНИЗАЦИЯ ПО СТАНДАРТИЗАЦИИ • ORGANISATION INTERNATIONALE DE NORMALISATION

Endless hexagonal belts for agricultural machinery, and groove sections of corresponding pulleys

Courroies hexagonales sans fin pour machines agricoles et profils de gorges des poulies correspondantes

iTeh STANDARD PREVIEW

First edition – 1978-05-01

(standards.iteh.ai)

[ISO 5289:1978](#)

<https://standards.iteh.ai/catalog/standards/sist/70be13d7-1667-4500-86ec-78168c02de0e/iso-5289-1978>

UDC 621.852.13 : 631.3

Ref. No. ISO 5289-1978 (E)

Descriptors : agricultural machinery, belt drives, hexagonal belts, grooved pulleys, dimensional measurement, dimensions, pulleys.

FOREWORD

ISO (the International Organization for Standardization) is a worldwide federation of national standards institutes (ISO member bodies). The work of developing International Standards is carried out through ISO technical committees. Every member body interested in a subject for which a technical committee has been set up has the right to be represented on that committee. International organizations, governmental and non-governmental, in liaison with ISO, also take part in the work.

Draft International Standards adopted by the technical committees are circulated to the member bodies for approval before their acceptance as International Standards by the ISO Council.

International Standard ISO 5289 was developed by Technical Committee ISO/TC 41, *Pulleys and belts (including veebelts)*, and was circulated to the member bodies in September 1976.

STANDARD PREVIEW
(standards.iteh.ai)

It has been approved by the member bodies of the following countries :

Austria	Italy	Sweden
Belgium	Japan	Turkey
Chile	Korea, Rep. of	United Kingdom
Denmark	Mexico	U.S.A.
Finland	Netherlands	U.S.S.R.
France	Philippines	Yugoslavia
Germany	South Africa, Rep. of	
India	Spain	

<https://standards.iteh.ai/catalog/standards/sist/70be13d7-1667-4500-86cc-78168cd249e/iso-5289-1978>

The member body of the following country expressed disapproval of the document on technical grounds :

Canada

Endless hexagonal belts for agricultural machinery, and groove sections of corresponding pulleys

iTeh STANDARD PREVIEW (standards.iteh.ai)

1 SCOPE AND FIELD OF APPLICATION

This International Standard lays down the main dimensions of endless hexagonal belts, generally intended for use on agricultural machinery (and, in particular, harvester-thresher machines), together with the groove sections of the corresponding fixed diameter pulleys.

the neutral axis, coinciding in practice with the transverse diagonal of this hexagon, is located therefore at half the height of the section.

The dimensions of these belts are shown in table 1.

2 REFERENCE

ISO/R 52, *Grooved pulleys for V-belts – Groove sections A, B, C, D, E.*

3 DIMENSIONAL SPECIFICATIONS

3.1 Belts

An endless hexagonal belt on an agricultural machine transmits a high degree of force per unit of section; when it approaches a groove pulley, its cross-section undergoes, as a result, appreciable deformation. For this reason, the various dimensions which are defined hereunder are to be taken as being those of the belt placed on the device used for the measurement of its length, and subjected to the measuring force F . The dimensions W and T are those relating to the parts of the belt when in contact with the measuring pulleys.

3.1.1 Cross-section (see figure 1)

The theoretical profile of these belts is a hexagon consisting of two equal isosceles trapezia joined at their wider base;

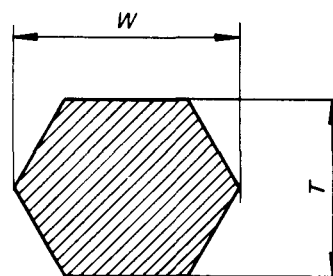

FIGURE 1 – Cross-section of belt

TABLE 1 – Cross-section nominal dimensions

Dimensions in millimetres

Designation	Symbol	Profile			
		HAA	HBB	HCC	HDD
Nominal width	W	13	17	22	32
Nominal height	T	10	13	17	25

3.1.2 Effective lengths of belts

The range of effective lengths is that of the R 40 series of preferred numbers, from 1 250 mm to 10 000 mm (see table 2).

TABLE 2 – Range of effective lengths of belts

Values in millimetres

Effective length	Tolerance		Profile			
	+ p/2	- p	HAA	HBB	HCC	HDD
1 250	8	16	+			
1 320	9	18	+			
1 400	9	18	+			
1 500	9	18	+			
1 600	9	18	+			
1 700	11	22	+			
1 800	11	22	+			
1 900	11	22	+			
2 000	11	22	+			
2 120	13	26	+	+		
2 240	13	26	+	+		
2 360	13	26	+	+	+	
2 500	13	26	+	+	+	
2 650	15	30	+	+	+	
2 800	15	30	+	+	+	
3 000	15	30	+	+	+	
3 150	15	30	+	+	+	
3 350	18	36	+	+	+	
3 550	18	36	+	+	+	
3 750	18	36		+	+	
4 000	18	36		+	+	+
4 250	22	44		+	+	+
4 500	22	44		+	+	+
4 750	22	44		+	+	+
5 000	22	44		+	+	+
5 300	26	52			+	+
5 600	26	52			+	+
6 000	26	52			+	+
6 300	26	52			+	+
6 700	32	64			+	+
7 100	32	64			+	+
7 500	32	64			+	+
8 000	32	64			+	+
8 500	39	78				+
9 000	39	78				+
9 500	39	78				+
10 000	39	78				+

NOTE – Reduced length tolerances can be used with the agreement of manufacturer and user.

3.1.3 Tolerance on length

The length of the belts is affected by the maximum admissible deviations of + p/2 and - p, where p is calculated, with a certain amount of approximation, using the formula :

$$p = 0,8 \sqrt[3]{L} + 0,006 L$$

L being the preferred number from the R 10 series equal to or immediately greater than the effective length, expressed in millimetres.

3.2 Pulleys

3.2.1 Pulleys having parallel axes of rotation

The hexagonal belts can be used with pulley profiles in accordance with ISO/R 52 for classical belt sections :

- section A grooved pulley for HAA belts;
- section B grooved pulley for HBB belts;
- section C grooved pulley for HCC belts;
- section D grooved pulley for HDD belts.

3.2.2 Pulleys whose axes of rotation are not parallel

In such cases, it is often necessary to increase the outside diameter of the pulley in relation to the effective diameter, and sometimes the angle of the groove in order to allow the belts to approach and leave the grooves without friction occurring with their edges.

It is not possible to determine any outline of groove which would suit all cases of transmission between shafts that are not parallel. However, certain national specifications define the geometrical characteristics that govern transmission between orthogonal shafts (known as quarter-turn drives) and particularly the special groove profile (known as "deep groove") to be used in this case.

4 MEASUREMENT OF LENGTH OF BELTS

4.1 Principle of measurement

The device recommended, shown in sketch form in figure 2, consists essentially of two grooved pulleys of similar functional dimensions, one of which is movable in the same plane as the belt by the measuring force F (see table 3).

Rotate the belt to make at least two complete revolutions of the belt, then measure the distance E between centres of the two pulleys.

4.2 Calculation of length

The effective length of the belt, i.e. the length measured at the level of its effective width l_{eff} , is obtained from the formula :

$$L_{eff} = 2 E + C_{eff}$$

C_{eff} indicating the effective circumference of the control pulleys (see table 3).

4.3 Groove section of measurement pulleys

Only the values of l_{eff} , of C_{eff} and of the angle of the groove α are of importance; the depth h in table 3 is given only for information.

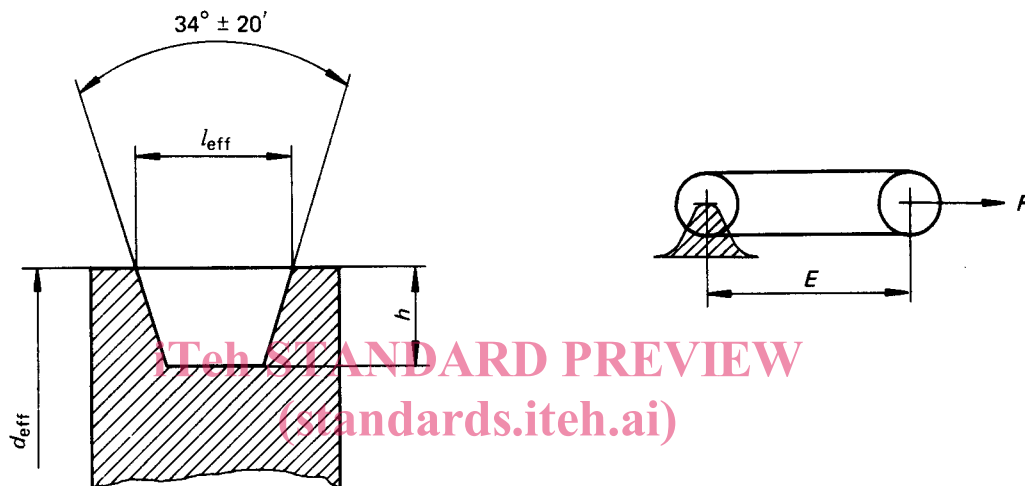

STANDARD PREVIEW
(standards.iteh.ai)
ISO 5289:1978
<https://standards.iteh.ai/catalog/standards/sist/70be13d7-1667-4500-86cc-78168c02de0e/iso-5289-1978>

FIGURE 2 – Measuring device

TABLE 3 – Characteristics of measuring pulleys and method of test

Designation	Symbol	Unit	Profile			
			HAA	HBB	HCC	HDD
Effective width	l_{eff}	mm	12,6	16,2	22,3	32,0
Minimum groove depth (approximate expression : $0,6 l_{eff}$)	h	mm	8	10	14	20
Effective diameter	d_{eff}	mm	95,49	127,32	190,99	286,48
Effective circumference	C_{eff}	mm	300	400	600	900
Measuring force	F	N	200	300	750	1 400
Groove angle	α	degree	34	34	34	34

5 RELATION BETWEEN EFFECTIVE DIAMETER AND PITCH DIAMETER

See figure 3.

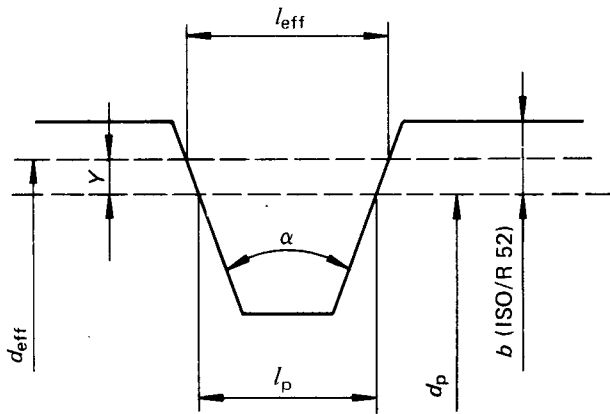

FIGURE 3 – Pulley diameters

The pitch diameter of V-belt pulleys, as defined in ISO/R 52, and the corresponding effective diameter when these pulleys are used with hexagonal belts are connected by the following formula :

$$d_{\text{eff}} = d_p + 2 Y$$

the values of factor Y being as given by table 4.

TABLE 4 – Values of factor Y

Values in millimetres

Belt section	Groove angle α		
	34°	36°	38°
A and HAA	2,6		2,3
B and HBB	3,6		3,2
C and HCC		5,1	4,8
D and HDD		7,7	7,3

iTeh STANDARD PREVIEW
(standards.iteh.ai)

ISO 5289:1978

<https://standards.iteh.ai/catalog/standards/sist/70be13d7-1667-4500-86ec-78168c02de0e/iso-5289-1978>

iTeh STANDARD PREVIEW
(standards.iteh.ai)

ISO 5289:1978

<https://standards.iteh.ai/catalog/standards/sist/70be13d7-1667-4500-86ec-78168c02de0e/iso-5289-1978>

iTeh STANDARD PREVIEW
(standards.iteh.ai)

ISO 5289:1978

<https://standards.iteh.ai/catalog/standards/sist/70be13d7-1667-4500-86ec-78168c02de0e/iso-5289-1978>