



Designation: D7774 – 22

Standard Test Method for Flexural Fatigue Properties of Plastics¹

This standard is issued under the fixed designation D7774; the number immediately following the designation indicates the year of original adoption or, in the case of revision, the year of last revision. A number in parentheses indicates the year of last reapproval. A superscript epsilon (ϵ) indicates an editorial change since the last revision or reapproval.

1. Scope*

1.1 This test method covers the determination of dynamic fatigue properties of plastics in flexure. This method is applicable to rigid and semi-rigid plastics. Stress and strain levels are below the proportional limit of the material where the strains and stresses are relatively elastic. Three-point or four-point bending systems are used to determine these properties.

1.2 This test method can be used with two procedures:

1.2.1 *Procedure A*, designed for materials that use three-point loading systems to determine flexural strength. Three-point loading system is used for this procedure.

1.2.2 *Procedure B*, designed for materials that use four-point loading systems to determine flexural strength. Four-point loading system is used for this procedure.

1.3 Comparative tests can be run in accordance with either procedure, provided that the procedure is found satisfactory for the material being tested.

1.4 The values stated in SI units are to be regarded as the standard. The values provided in parentheses are for information only.

1.5 *This standard does not purport to address all of the safety concerns, if any, associated with its use. It is the responsibility of the user of this standard to establish appropriate safety, health, and environmental practices and determine the applicability of regulatory limitations prior to use.*

NOTE 1—This standard and ISO 13003 address the same subject matter, but differ in technical content and results cannot be directly compared between the two test methods.

1.6 *This international standard was developed in accordance with internationally recognized principles on standardization established in the Decision on Principles for the Development of International Standards, Guides and Recommendations issued by the World Trade Organization Technical Barriers to Trade (TBT) Committee.*

¹ This test method is under the jurisdiction of ASTM Committee D20 on Plastics and is the direct responsibility of Subcommittee D20.10 on Mechanical Properties.

Current edition approved July 1, 2022. Published July 2022. Last previous edition approved in 2017 as D7774 - 17. DOI:10.1520/D7774-22.

2. Referenced Documents

2.1 ASTM Standards:²

- D618 Practice for Conditioning Plastics for Testing
- D638 Test Method for Tensile Properties of Plastics
- D790 Test Methods for Flexural Properties of Unreinforced and Reinforced Plastics and Electrical Insulating Materials
- D792 Test Methods for Density and Specific Gravity (Relative Density) of Plastics by Displacement
- D883 Terminology Relating to Plastics
- D1505 Test Method for Density of Plastics by the Density-Gradient Technique
- D2839 Practice for Use of a Melt Index Strand for Determining Density of Polyethylene
- D3479/D3479M Test Method for Tension-Tension Fatigue of Polymer Matrix Composite Materials
- D4883 Test Method for Density of Polyethylene by the Ultrasound Technique
- D5947 Test Methods for Physical Dimensions of Solid Plastics Specimens
- D6272 Test Method for Flexural Properties of Unreinforced and Reinforced Plastics and Electrical Insulating Materials by Four-Point Bending
- E4 Practices for Force Calibration and Verification of Testing Machines
- E83 Practice for Verification and Classification of Extensometer Systems
- E177 Practice for Use of the Terms Precision and Bias in ASTM Test Methods
- E691 Practice for Conducting an Interlaboratory Study to Determine the Precision of a Test Method
- E1942 Guide for Evaluating Data Acquisition Systems Used in Cyclic Fatigue and Fracture Mechanics Testing

2.2 ISO Standard:

- ISO 13003 Fibre-Reinforced Plastics—Determination of Fatigue Properties Under Cyclic Loading Conditions³

² For referenced ASTM standards, visit the ASTM website, www.astm.org, or contact ASTM Customer Service at service@astm.org. For *Annual Book of ASTM Standards* volume information, refer to the standard's Document Summary page on the ASTM website.

³ Available from American National Standards Institute (ANSI), 25 W. 43rd St., 4th Floor, New York, NY 10036, <http://www.ansi.org>.

*A Summary of Changes section appears at the end of this standard

3. Terminology

3.1 *Definitions*—Definitions applying to this test method appear in Terminology **D883**.

3.2 *mean strain, n*—the algebraic average of the maximum and minimum strains in one cycle.

3.3 *mean stress, n*—the algebraic average of the maximum and minimum stresses in one cycle.

3.4 *R Ratio, n*—the ratio of the minimum stress or strain to the maximum stress or strain that the specimen is loaded.

3.5 *proportional limit, n*—the maximum elastic stress or strain exhibited by the material as observed during Test Methods **D790** (for Procedure A) or Test Method **D6272** (for Procedure B).

4. Summary of Test Method

4.1 *Procedure A*—A specimen of rectangular cross section is braced by two double-sided supports and is loaded by means of a double-sided loading nose midway between the supports. A support span-to-depth ratio of 16:1 is used. The specimen is cyclically loaded to predetermined stress or strain range at a uniform frequency and R ratio until the specimen ruptures or yields. From these tests, fatigue strengths can be determined at specified numbers of cycles. At least four different stress or strain levels are tested to construct a stress versus number of cycles to failure (S-N) curve or a strain versus number of cycles to failure (r-N) to determine the flexural endurance limit of the material at a specific R ratio.

4.2 *Procedure B*—A specimen of rectangular cross section is braced by two double-sided supports and is loaded by means of two double-sided loading noses, each an equal distance from the adjacent support. Load span-to-support span ratios can be 1:2 or 1:3. The specimen is cyclically loaded to a predetermined stress or strain range at a uniform frequency and R ratio until the specimen ruptures or yields. From these tests, fatigue strengths can be determined at specified numbers of cycles. At least four different stress or strain levels are tested to construct a stress versus number of cycles to failure (S-N) curve or a strain versus number of cycles to failure (r-N) to determine the flexural endurance limit of the material at a specific R ratio.

5. Significance and Use

5.1 These fatigue tests are used to determine the effect of processing, surface condition, stress, and so forth, on the fatigue resistance of plastic material subjected to flexural stress for relatively large numbers of cycles. The results can also be used as a guide for the selection of plastic materials for service under conditions of repeated flexural stress.

5.2 Properties can vary with specimen depth and test frequency. Test frequency can be 1-25 Hz but it is recommended that a frequency of 5 Hz or less be used.

5.3 Material response in fatigue is not identical for all plastics. If a plastic does not exhibit an elastic region, where strain is reversible, plastic deformation will occur during fatigue testing, causing the amplitude of the programmed load or deformation to change during testing. In this situation,

caution shall be taken when using the results for design as they are generally not indicative of the true fatigue properties of the material.

5.4 The results of these fatigue tests are suitable for application in design only when the specimen test conditions realistically simulate service conditions or some methodology of accounting for service conditions is available and clearly defined.

5.5 This procedure accommodates various specimen preparation techniques. Comparison of results obtained from specimens prepared in different manners shall not be considered comparable unless equivalency has been demonstrated.

6. Apparatus

6.1 *Testing Machine*—The testing machine shall essentially meet the specifications of Test Method **D790** except as described below. The error in the deflection measuring system shall not exceed $\pm 0.5\%$ of the maximum deflection. The machine shall be able to execute sinusoidal or square/trapezoidal load or deflection programs at the specified test frequency and maintain an error of $\pm 1\%$ or less of the maximum programmed load or deflection.

6.2 *Recording Equipment*—Calibrated equipment must be used to record the following information during testing at a data acquisition rate and filter in accordance with Guide **E1942**:

- 6.2.1 Load versus time,
- 6.2.2 Deflection versus time, and
- 6.2.3 Number of cycles.

6.3 *Micrometers*—Applicable apparatus in accordance with Test Methods **D5947** shall be used to measure the width and thickness of the test specimen.

6.4 Bending Fixture

6.4.1 *Procedure A*—A three-point bending fixture shall be used. A double-sided loading nose and two double-sided supports are required for this procedure. One side loads or supports the top of the specimen and the other loads or supports the bottom of the specimen. The dimensions of both sides shall be identical. The radii of the noses and supports will be in accordance with Test Method **D790**. An example of a fixture configuration for Procedure A is shown in **Fig. 1**. This fixture has a support span range of 50.8 to 254 mm (2 to 10 in.) at 50.8 mm (2 in.) intervals.

6.4.1.1 The supports are set to simply support the specimen using minimal pressure to hold the specimen in place. The specimen shall be long enough so that the ends do not slip from the supports during testing.

6.4.2 *Procedure B*—Four-point bending fixture shall be used. Two double-sided loading noses and two double-sided supports are required for this procedure. One side loads or supports the top of the specimen and the other loads or supports the bottom of the specimen. The dimensions of both sides shall be identical. The radii of the noses and supports will be in accordance with Test Method **D6272**. Load-span-to-support-span ratios shall be set at 1:2 or 1:3. An example of a 1:3 load-span-to-support-span ratio fixture configuration for Procedure B is shown in **Fig. 2**. This fixture has a load span range

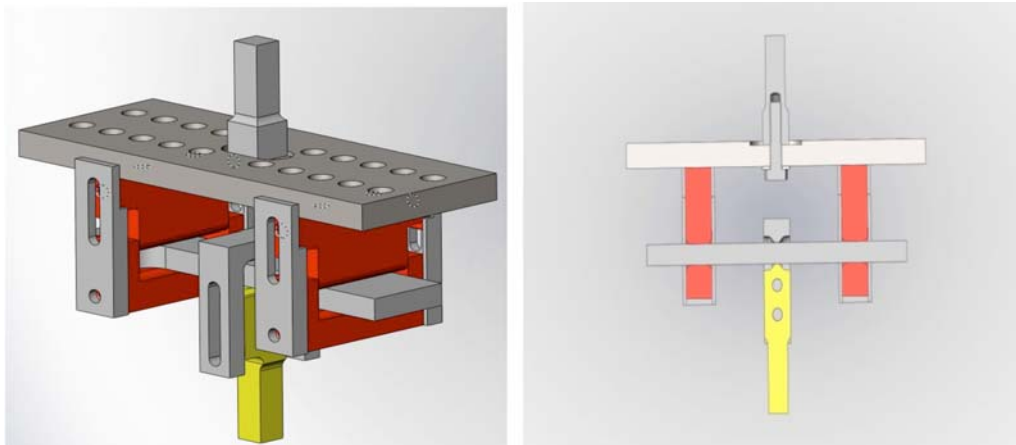

FIG. 1 Three-Point Fixture for Flexural Fatigue Tests

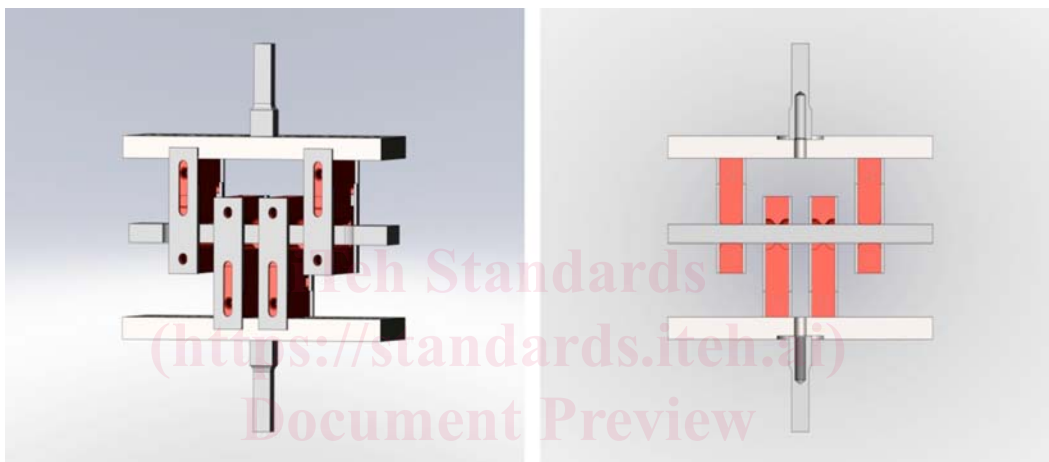

FIG. 2 Four-Point Fixture for Flexural Fatigue Tests

[ASTM D7774-22](https://standards.iteh.ai/catalog/standards/sist/6e415da2-4d03-425b-9a55-f6354cefac1f/astm-d7774-22)

<https://standards.iteh.ai/catalog/standards/sist/6e415da2-4d03-425b-9a55-f6354cefac1f/astm-d7774-22>

of 50.8 to 101.6 mm (2 to 4 in.) and a support span range of 101.6 to 203.2 mm (4 to 8 in.), both at 50.8 mm (2 in.) intervals.

6.4.2.1 The supports are set to simply support the specimen using minimal pressure to hold the specimen in place. The specimen shall be long enough so that the ends do not slip from the supports during testing.

7. Sampling, Test Specimens, and Test Units

7.1 Specimens shall be taken from samples that accurately represent the material or design that is being tested.

7.2 The specimens can be cut from sheets, plates, or molded shapes, or can be molded to the desired finished dimensions. The actual dimensions used for calculations shall be measured in accordance with Test Methods [D5947](#).

7.3 *Procedure A*—Specimen dimensions, shape, surfaces, and limitations shall be in compliance with Test Method [D790](#). The specimen shall be long enough to allow for overhanging on each end of at least 10 % of the support span, but in no case less than 12.8 mm (1/2 in.). Overhang shall be sufficient to prevent the specimen from slipping through the supports.

7.4 *Procedure B*—Specimen dimensions, shape, surfaces, and limitations shall be in compliance with Test Method [D6272](#). This test method only covers specimens with 1:2 or 1:3 load span-to-support span ratios. The specimen shall be long enough to allow for overhanging on each end of at least 10 % of the support span, but in no case less than 12.8 mm (1/2 in.). Overhang shall be sufficient to prevent the specimen from slipping through the supports.

7.5 Specimens that do not naturally fail in the load span during testing can be made thinner in the gauge area to promote failure in the load span. The reduced width of the specimen shall be used to calculate the test stress or strain.

7.6 Samples cut from non-uniform thick molded part sections shall be machined equally and minimally on both sides to create a uniform thickness in the support span. It must be noted that machining the thickness of plastic can change the mechanical properties and caution shall be taken when applying the results to design.

7.7 It is recommended that density measurements be taken from each sample in the support span in accordance with Test Methods [D792](#), Test Method [D1505](#), Practice [D2839](#) or Test

Method **D4883** to ensure that the process used to fabricate the specimens creates consistent and uniform material.

8. Number of Test Specimens

8.1 At least three test specimens shall be tested at each of the four stress or strain levels (minimum of twelve specimens for each test). For additional sample sizes consult Table 1 of Test Method **D3479/D3479M**.

8.2 In the case of anisotropic materials, a single direction shall be chosen and maintained for all stress or strain levels.

9. Calibration and Standardization

9.1 All equipment shall be calibrated in accordance with the manufacturer's specifications and Practice **E4**.

9.2 Specimens for each test shall be identically processed and prepared for accurate results.

10. Conditioning

10.1 *Conditioning*—Condition the test specimens in accordance with Procedure A of Practice **D618** unless otherwise specified by contract or the relevant ASTM material specification. Condition time is specified as a minimum. Temperature and humidity tolerances shall be in accordance with Section 7 of Practice **D618** unless specified differently by contract or material specification.

10.2 *Test Conditions*—Conduct the tests at the same temperature and humidity used for conditioning with tolerances in accordance with Section 7 of Practice **D618** unless otherwise specified by contract or the relevant ASTM material specification.

11. Procedure

11.1 *Specimen Measurements*—Take measurements of all specimens. Measure and record the depth and width of the specimen to the nearest 0.03 mm (0.001 in.) at the center of the support span. For specimens less than 2.54 mm (0.100 in.) in depth, measure the depth to the nearest 0.003 mm (0.0001 in.). Take three different measurements of each dimension at the midpoint of the support span and average the resulting measurements. These measurements shall be made in accordance with Test Methods **D5947**.

11.2 Apparatus Setup:

11.2.1 Procedure A:

11.2.1.1 Determine and set the support span. Measure the span accurately to the nearest 0.1 mm (0.004 in.) for spans less than 63 mm (2.5 in.). For spans greater than or equal to 63 mm (2.5 in.), measure to the nearest 0.3 mm (0.012 in.). Use the actual measured span for all calculations.

11.2.1.2 Position the three-point bend fixture so that the load nose and load axis of the testing machine are co-axial. This insures that no moments are created on the apparatus and that the load is being applied directly at the midpoint of the fixture.

11.2.1.3 Position the specimen on the supports so that the load nose and midpoint of the specimen are aligned and the bottom face of the specimen is perpendicular to the loading axis.

11.2.2 Procedure B:

11.2.2.1 Determine and set the support span and the load span. Measure the spans accurately to the nearest 0.1 mm (0.004 in.) for spans less than 63 mm (2.5 in.). For spans greater than or equal to 63 mm (2.5 in.), measure to the nearest 0.3 mm (0.012 in.). Use the actual measured spans for all calculations.

11.2.2.2 Position the four-point bend fixture so that the centerline between the load noses and the load axis of the testing machine is co-axial. This insures that no moments are created on the apparatus and that the load is being applied directly at the midpoint of the fixture.

11.2.2.3 Position the specimen on the supports so that the centerline between the load noses and the middle of the specimen are aligned and the bottom face of the specimen is perpendicular to the loading axis.

11.3 Test Program Setup:

11.3.1 Program the testing machine to follow a dynamic load (sinusoidal, square, or trapezoidal) or deflection waveform with the amplitude and mean values set to the selected load or deflection level and R ratio. Unless specified, the default waveform shall be sinusoidal and the R ratio value at -1 . The selected level shall be below the proportional limit of the material as determined by Test Methods **D790** (for Procedure A) or Test Method **D6272** (for Procedure B). Set the test frequency (maximum 25 Hz).

11.3.2 *Stress Level Selection*—Stress levels shall not exceed the proportional limit of the material. The associated load of a selected stress level can be determined by the following equations:

Procedure A:

$$P = \frac{2Sbd^2}{3L} \quad (1)$$

Procedure B, 1:3 Load to Support Span

$$P = \frac{Sbd^2}{L} \quad (2)$$

Procedure B, 1:2 Load to Support Span

$$P = \frac{4Sbd^2}{3L} \quad (3)$$

where:

P = load in N,

S = flexural stress in MPa,

L = support span in mm,

b = width of specimen in mm, and

d = depth of beam in mm.

11.3.3 *Strain Level Selection*—Strain levels shall not exceed the proportional limit of the material. The associated deflection of a selected strain level can be determined by the following equation:

Procedure A:

$$D = \frac{rL^2}{6d} \quad (4)$$

Procedure B, 1:3 Load to Support Span

$$D = \frac{rL^2}{4.70d} \quad (5)$$