



Designation: D638 – 22

# Standard Test Method for Tensile Properties of Plastics<sup>1</sup>

This standard is issued under the fixed designation D638; the number immediately following the designation indicates the year of original adoption or, in the case of revision, the year of last revision. A number in parentheses indicates the year of last reapproval. A superscript epsilon ( $\epsilon$ ) indicates an editorial change since the last revision or reapproval.

*This standard has been approved for use by agencies of the U.S. Department of Defense.*

## 1. Scope\*

1.1 This test method covers the determination of the tensile properties of unreinforced and reinforced plastics in the form of standard dumbbell-shaped test specimens when tested under defined conditions of pretreatment, temperature, humidity, and testing machine speed.

1.2 This test method is applicable for testing materials of any thickness up to 14 mm (0.55 in.). However, for testing specimens in the form of thin sheeting, including film less than 1.0 mm (0.04 in.) in thickness, ASTM standard **D882** is the preferred test method. Materials with a thickness greater than 14 mm (0.55 in.) shall be reduced by machining.

1.3 This test method includes the option of determining Poisson's ratio at room temperature.

NOTE 1—This standard and ISO 527-1 address the same subject matter, but differ in technical content.

NOTE 2—This test method is not intended to cover precise physical procedures. It is recognized that the constant rate of crosshead movement type of test leaves much to be desired from a theoretical standpoint, that wide differences may exist between rate of crosshead movement and rate of strain between gage marks on the specimen, and that the testing speeds specified disguise important effects characteristic of materials in the plastic state. Further, it is realized that variations in the thicknesses of test specimens, which are permitted by these procedures, produce variations in the surface-volume ratios of such specimens, and that these variations may influence the test results. Hence, where directly comparable results are desired, all samples should be of equal thickness. Special additional tests should be used where more precise physical data are needed.

NOTE 3—This test method may be used for testing phenolic molded resin or laminated materials. However, where these materials are used as electrical insulation, such materials should be tested in accordance with Test Methods **D229** and Test Method **D651**.

NOTE 4—For tensile properties of resin-matrix composites reinforced with oriented continuous or discontinuous high modulus  $>20$ -GPa ( $>3.0 \times 10^6$ -psi) fibers, tests shall be made in accordance with Test Method **D3039/D3039M**.

1.4 Test data obtained by this test method have been found to be useful in engineering design. However, it is important to

consider the precautions and limitations of this method found in **Note 2** and **Section 4** before considering these data for engineering design.

1.5 The values stated in SI units are to be regarded as standard. The values given in parentheses are for information only.

1.6 *This standard does not purport to address all of the safety concerns, if any, associated with its use. It is the responsibility of the user of this standard to establish appropriate safety, health, and environmental practices and determine the applicability of regulatory limitations prior to use.*

1.7 *This international standard was developed in accordance with internationally recognized principles on standardization established in the Decision on Principles for the Development of International Standards, Guides and Recommendations issued by the World Trade Organization Technical Barriers to Trade (TBT) Committee.*

## 2. Referenced Documents

### 2.1 ASTM Standards:<sup>2</sup>

- D229** Test Methods for Rigid Sheet and Plate Materials Used for Electrical Insulation
- D412** Test Methods for Vulcanized Rubber and Thermoplastic Elastomers—Tension
- D618** Practice for Conditioning Plastics for Testing
- D651** Test Method for Test for Tensile Strength of Molded Electrical Insulating Materials (Withdrawn 1989)<sup>3</sup>
- D882** Test Method for Tensile Properties of Thin Plastic Sheet
- D883** Terminology Relating to Plastics
- D1822** Test Method for Determining the Tensile-Impact Resistance of Plastics
- D3039/D3039M** Test Method for Tensile Properties of Polymer Matrix Composite Materials
- D4000** Classification System for Specifying Plastic Materials

<sup>1</sup> This test method is under the jurisdiction of ASTM Committee **D20** on Plastics and is the direct responsibility of Subcommittee **D20.10** on Mechanical Properties.

Current edition approved July 1, 2022. Published July 2022. Originally approved in 1941. Last previous edition approved in 2014 as D638 - 14. DOI: 10.1520/D0638-22.

<sup>2</sup> For referenced ASTM standards, visit the ASTM website, [www.astm.org](http://www.astm.org), or contact ASTM Customer Service at [service@astm.org](mailto:service@astm.org). For *Annual Book of ASTM Standards* volume information, refer to the standard's Document Summary page on the ASTM website.

<sup>3</sup> The last approved version of this historical standard is referenced on [www.astm.org](http://www.astm.org).

\*A Summary of Changes section appears at the end of this standard

D4066 Classification System for Nylon Injection and Extrusion Materials (PA)  
 D5947 Test Methods for Physical Dimensions of Solid Plastics Specimens  
 E4 Practices for Force Calibration and Verification of Testing Machines  
 E83 Practice for Verification and Classification of Extensometer Systems  
 E132 Test Method for Poisson's Ratio at Room Temperature  
 E456 Terminology Relating to Quality and Statistics  
 E691 Practice for Conducting an Interlaboratory Study to Determine the Precision of a Test Method  
 E2935 Practice for Evaluating Equivalence of Two Testing Processes  
 2.2 ISO Standard:<sup>4</sup>  
 ISO 527-1 Determination of Tensile Properties

### 3. Terminology

3.1 Terms used in this standard are defined in accordance with Terminology D883, and Annex A2. For terms relating to precision and bias and associated issues, the terms used in this standard are defined in accordance with Terminology E456.

### 4. Significance and Use

4.1 This test method is designed to produce tensile property data for the control and specification of plastic materials. These data are also useful for qualitative characterization and for research and development.

4.2 Some material specifications that require the use of this test method, but with some procedural modifications that take precedence when adhering to the specification. Therefore, it is advisable to refer to that material specification before using this test method. Table 1 in Classification D4000 lists the ASTM materials standards that currently exist.

4.3 Tensile properties are known to vary with specimen preparation and with speed and environment of testing. Consequently, where precise comparative results are desired, these factors must be carefully controlled.

4.4 It is realized that a material cannot be tested without also testing the method of preparation of that material. Hence, when comparative tests of materials per se are desired, exercise great care to ensure that all samples are prepared in exactly the same way, unless the test is to include the effects of sample preparation. Similarly, for referee purposes or comparisons within any given series of specimens, care shall be taken to secure the maximum degree of uniformity in details of preparation, treatment, and handling.

4.5 Tensile properties provide useful data for plastics engineering design purposes. However, because of the high degree of sensitivity exhibited by many plastics to rate of straining and environmental conditions, data obtained by this test method cannot be considered valid for applications involving load-time scales or environments widely different from those of this test method. In cases of such dissimilarity, no reliable estimation of

the limit of usefulness can be made for most plastics. This sensitivity to rate of straining and environment necessitates testing over a broad load-time scale (including impact and creep) and range of environmental conditions if tensile properties are to suffice for engineering design purposes.

NOTE 5—Since the existence of a true elastic limit in plastics (as in many other organic materials and in many metals) is debatable, the propriety of applying the term “elastic modulus” in its quoted, generally accepted definition to describe the “stiffness” or “rigidity” of a plastic has been seriously questioned. The exact stress-strain characteristics of plastic materials are highly dependent on such factors as rate of application of stress, temperature, previous history of specimen, etc. However, stress-strain curves for plastics, determined as described in this test method, almost always show a linear region at low stresses, and a straight line drawn tangent to this portion of the curve permits calculation of an elastic modulus of the usually defined type. Such a constant is useful if its arbitrary nature and dependence on time, temperature, and similar factors are realized.

### 5. Apparatus

5.1 *Testing Machine*—A testing machine of the constant-rate-of-crosshead-movement type and comprising essentially the following:

5.1.1 *Fixed Member*—A fixed or essentially stationary member carrying one grip.

5.1.2 *Movable Member*—A movable member carrying a second grip.

5.1.3 *Grips*—Grips for holding the test specimen between the fixed member and the movable member of the testing machine can be either the fixed or self-aligning type.

5.1.3.1 *Fixed grips* are rigidly attached to the fixed and movable members of the testing machine. When this type of grip is used take extreme care to ensure that the test specimen is inserted and clamped so that the long axis of the test specimen coincides with the direction of pull through the center line of the grip assembly.

5.1.3.2 *Self-aligning grips* are attached to the fixed and movable members of the testing machine in such a manner that they will move freely into alignment as soon as any load is applied so that the long axis of the test specimen will coincide with the direction of the applied pull through the center line of the grip assembly. Align the specimens as perfectly as possible with the direction of pull so that no rotary motion that may induce slippage will occur in the grips; there is a limit to the amount of misalignment self-aligning grips will accommodate.

5.1.3.3 The test specimen shall be held in such a way that slippage relative to the grips is prevented insofar as possible. Grip surfaces that are deeply scored or serrated with a pattern similar to those of a coarse single-cut file, serrations about 2.4 mm (0.09 in.) apart and about 1.6 mm (0.06 in.) deep, have been found satisfactory for most thermoplastics. Finer serrations have been found to be more satisfactory for harder plastics, such as the thermosetting materials. It is important that the serrations be kept clean and sharp. Should breaking in the grips occur, even when deep serrations or abraded specimen surfaces are used, other techniques shall be used. Other techniques that have been found useful, particularly with smooth-faced grips, are abrading that portion of the surface of the specimen that will be in the grips, and interposing thin

<sup>4</sup> Available from American National Standards Institute (ANSI), 25 W. 43rd St., 4th Floor, New York, NY 10036, <http://www.ansi.org>.

pieces of abrasive cloth, abrasive paper, or plastic, or rubber-coated fabric, commonly called hospital sheeting, between the specimen and the grip surface. No. 80 double-sided abrasive paper has been found effective in many cases. An open-mesh fabric, in which the threads are coated with abrasive, has also been effective. Reducing the cross-sectional area of the specimen may also be effective. The use of special types of grips is sometimes necessary to eliminate slippage and breakage in the grips.

**5.1.4 Drive Mechanism**—A drive mechanism for imparting a uniform, controlled velocity to the movable member with respect to the stationary member. This velocity is to be regulated as specified in Section 8.

**5.1.5 Load Indicator**—A suitable load-indicating mechanism capable of showing the total tensile load carried by the test specimen when held by the grips. This mechanism shall be essentially free of inertia lag at the specified rate of testing and shall indicate the load with an accuracy of  $\pm 1\%$  of the indicated value, or better. The accuracy of the testing machine shall be verified in accordance with Practices E4.

**NOTE 6**—Experience has shown that many testing machines now in use are incapable of maintaining accuracy for as long as the periods between inspection recommended in Practices E4. Hence, it is recommended that each machine be studied individually and verified as often as may be found necessary. It frequently will be necessary to perform this function daily.

**5.1.6** The fixed member, movable member, drive mechanism, and grips shall be constructed of such materials and in such proportions that the total elastic longitudinal strain of the system constituted by these parts does not exceed 1 % of the total longitudinal strain between the two gage marks on the test specimen at any time during the test and at any load up to the rated capacity of the machine.

**5.1.7 Crosshead Extension Indicator**—A suitable extension indicating mechanism capable of showing the amount of change in the separation of the grips, that is, crosshead movement. This mechanism shall be essentially free of inertial lag at the specified rate of testing and shall indicate the crosshead movement with an accuracy of  $\pm 10\%$  of the indicated value.

**5.2 Extension Indicator (extensometer)**—A suitable instrument shall be used for determining the distance between two designated points within the gauge length of the test specimen as the specimen is stretched. For referee purposes, the extensometer must be set at the full gage length of the specimen, as shown in Fig. 1. It is desirable, but not essential, that this instrument automatically record this distance, or any change in it, as a function of the load on the test specimen or of the elapsed time from the start of the test, or both. If only the latter is obtained, load-time data must also be taken. This instrument shall be essentially free of inertia at the specified speed of testing. Extensometers shall be classified, and their calibration periodically verified in accordance with Practice E83.

**5.2.1 Modulus-of-Elasticity Measurements**—For modulus-of-elasticity measurements, an extensometer with a maximum strain error of 0.0002 mm/mm (in./in.) that automatically and continuously records shall be used. An extensometer classified by Practice E83 as fulfilling the requirements of a B-2

classification within the range of use for modulus measurements meets this requirement.

**5.2.2 Low-Extension Measurements**—For elongation-at-yield and low-extension measurements (nominally 20 % or less), the same above extensometer, attenuated to 20 % extension, is acceptable. In any case, the extensometer system must meet at least Class C (Practice E83) requirements, which include a fixed strain error of 0.001 strain or  $\pm 1.0\%$  of the indicated strain, whichever is greater.

**5.2.3 High-Extension Measurements**—For making measurements at elongations greater than 20 %, measuring techniques with error no greater than  $\pm 10\%$  of the measured value are acceptable.

**5.3 Micrometers**—Apparatus for measuring the width and thickness of the test specimen shall comply with the requirements of Test Method D5947.

## 6. Test Specimens

**6.1 Sheet, Plate, and Molded Plastics:**

**6.1.1 Rigid and Semirigid Plastics**—The test specimen shall conform to the dimensions shown in Fig. 1. The Type I specimen is the preferred specimen and shall be used where sufficient material having a thickness of 7 mm (0.28 in.) or less is available. The Type II specimen is recommended when a material does not break in the narrow section with the preferred Type I specimen. The Type V specimen shall be used where only limited material having a thickness of 4 mm (0.16 in.) or less is available for evaluation, or where a large number of specimens are to be exposed in a limited space (thermal and environmental stability tests, etc.). The Type IV specimen is generally used when direct comparisons are required between materials in different rigidity cases (that is, nonrigid and semirigid). The Type III specimen must be used for all materials with a thickness of greater than 7 mm (0.28 in.) but not more than 14 mm (0.55 in.).

**6.1.2 Nonrigid Plastics**—The test specimen shall conform to the dimensions shown in Fig. 1. The Type IV specimen shall be used for testing nonrigid plastics with a thickness of 4 mm (0.16 in.) or less. The Type III specimen must be used for all materials with a thickness greater than 7 mm (0.28 in.) but not more than 14 mm (0.55 in.).

**6.1.3 Reinforced Composites**—The test specimen for reinforced composites, including highly orthotropic laminates, shall conform to the dimensions of the Type I specimen shown in Fig. 1.

**6.1.4 Preparation**—Methods of preparing test specimens include injection molding, machining operations, or die cutting, from materials in sheet, plate, slab, or similar form. Materials thicker than 14 mm (0.55 in.) shall be machined to 14 mm (0.55 in.) for use as Type III specimens.

**NOTE 7**—Test results have shown that for some materials such as glass cloth, SMC, and BMC laminates, other specimen types should be considered to ensure breakage within the gage length of the specimen, as mandated by 7.3.

**NOTE 8**—When preparing specimens from certain composite laminates such as woven roving, or glass cloth, exercise care in cutting the specimens parallel to the reinforcement. The reinforcement will be significantly weakened by cutting on a bias, resulting in lower laminate properties, unless testing of specimens in a direction other than parallel

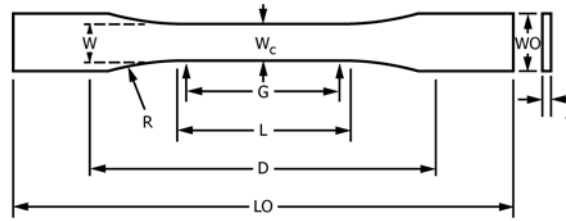

TYPES I, II, III & V

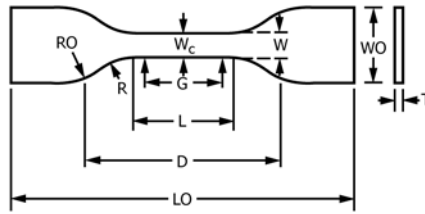

TYPE IV

Specimen Dimensions for Thickness,  $T$ , mm (in.)<sup>A</sup>

Dimensions (see drawings)	7 (0.28) or under		Over 7 to 14 (0.28 to 0.55), incl		4 (0.16) or under		Tolerances
	Type I	Type II	Type III	Type IV <sup>B</sup>	Type V <sup>C,D</sup>		
$W$ —Width of narrow section <sup>E,F</sup>	13 (0.50)	6 (0.25)	19 (0.75)	6 (0.25)	3.18 (0.125)	$\pm 0.5$ ( $\pm 0.02$ ) <sup>B,C</sup>	
$L$ —Length of narrow section	57 (2.25)	57 (2.25)	57 (2.25)	33 (1.30)	9.53 (0.375)	$\pm 0.5$ ( $\pm 0.02$ ) <sup>C</sup>	
$W_O$ —Width overall, min <sup>G</sup>	19 (0.75)	19 (0.75)	29 (1.13)	19 (0.75)	...	+ 6.4 ( + 0.25)	
$W_O$ —Width overall, min <sup>G</sup>	...	...	...	...	9.53 (0.375)	+ 3.18 ( + 0.125)	
$LO$ —Length overall, min <sup>H</sup>	165 (6.5)	183 (7.2)	246 (9.7)	115 (4.5)	63.5 (2.5)	no max (no max)	
$G$ —Gage length <sup>I</sup>	50 (2.00)	50 (2.00)	50 (2.00)	...	7.62 (0.300)	$\pm 0.25$ ( $\pm 0.010$ ) <sup>C</sup>	
$G$ —Gage length <sup>I</sup>	...	...	...	25 (1.00)	...	$\pm 0.13$ ( $\pm 0.005$ )	
$D$ —Distance between grips	115 (4.5)	135 (5.3)	115 (4.5)	65 (2.5) <sup>J</sup>	25.4 (1.0)	$\pm 5$ ( $\pm 0.2$ )	
$R$ —Radius of fillet	76 (3.00)	76 (3.00)	76 (3.00)	14 (0.56)	12.7 (0.5)	$\pm 1$ ( $\pm 0.04$ ) <sup>C</sup>	
$RO$ —Outer radius (Type IV)	...	...	...	25 (1.00)	...	$\pm 1$ ( $\pm 0.04$ )	

<sup>A</sup>Thickness,  $T$ , shall be  $3.2 \pm 0.4$  mm ( $0.13 \pm 0.02$  in.) for all types of molded specimens, and for other Types I and II specimens where possible. If specimens are machined from sheets or plates, thickness,  $T$ , shall be the thickness of the sheet or plate provided this does not exceed the range stated for the intended specimen type. For sheets of nominal thickness greater than 14 mm (0.55 in.) the specimens shall be machined to  $14 \pm 0.4$  mm ( $0.55 \pm 0.02$  in.) in thickness, for use with the Type III specimen. For sheets of nominal thickness between 14 and 51 mm (0.55 and 2 in.) approximately equal amounts shall be machined from each surface. For thicker sheets both surfaces of the specimen shall be machined, and the location of the specimen with reference to the original thickness of the sheet shall be noted. Tolerances on thickness less than 14 mm (0.55 in.) shall be those standard for the grade of material tested.

<sup>B</sup>For the Type IV specimen, the internal width of the narrow section of the die shall be  $6.00 \pm 0.05$  mm ( $0.250 \pm 0.002$  in.). The dimensions are essentially those of Die C in Test Methods D412.

<sup>C</sup>The Type V specimen shall be machined or die cut to the dimensions shown, or molded in a mold whose cavity has these dimensions. The dimensions shall be:

- $W = 3.18 \pm 0.03$  mm ( $0.125 \pm 0.001$  in.),
- $L = 9.53 \pm 0.08$  mm ( $0.375 \pm 0.003$  in.),
- $G = 7.62 \pm 0.02$  mm ( $0.300 \pm 0.001$  in.), and
- $R = 12.7 \pm 0.08$  mm ( $0.500 \pm 0.003$  in.).

The other tolerances are those in the table.

<sup>D</sup>Supporting data on the introduction of the L specimen of Test Method D1822 as the Type V specimen are available from ASTM Headquarters. Request RR:D20-1038.

<sup>E</sup>The tolerances of the width at the center  $W_c$  shall be  $+0.00$  mm,  $-0.10$  mm ( $+0.000$  in.,  $-0.004$  in.) compared with width  $W$  at other parts of the reduced section. Any reduction in  $W$  at the center shall be gradual, equally on each side so that no abrupt changes in dimension result.

<sup>F</sup>For molded specimens, a draft of not over 0.13 mm (0.005 in.) is allowed for either Type I or II specimens 3.2 mm (0.13 in.) in thickness. See diagram below and this shall be taken into account when calculating width of the specimen. Thus a typical section of a molded Type I specimen, having the maximum allowable draft, could be as follows:

<sup>G</sup>Overall widths greater than the minimum indicated are used for some materials in order to avoid breaking in the grips.

<sup>H</sup>Overall lengths greater than the minimum indicated are used for some materials to avoid breaking in the grips or to satisfy special test requirements.

<sup>I</sup>Test marks or initial extensometer span.

<sup>J</sup>When self-tightening grips are used, for highly extensible polymers, the distance between grips will depend upon the types of grips used and may not be critical if maintained uniform once chosen.

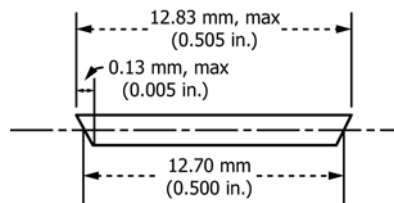
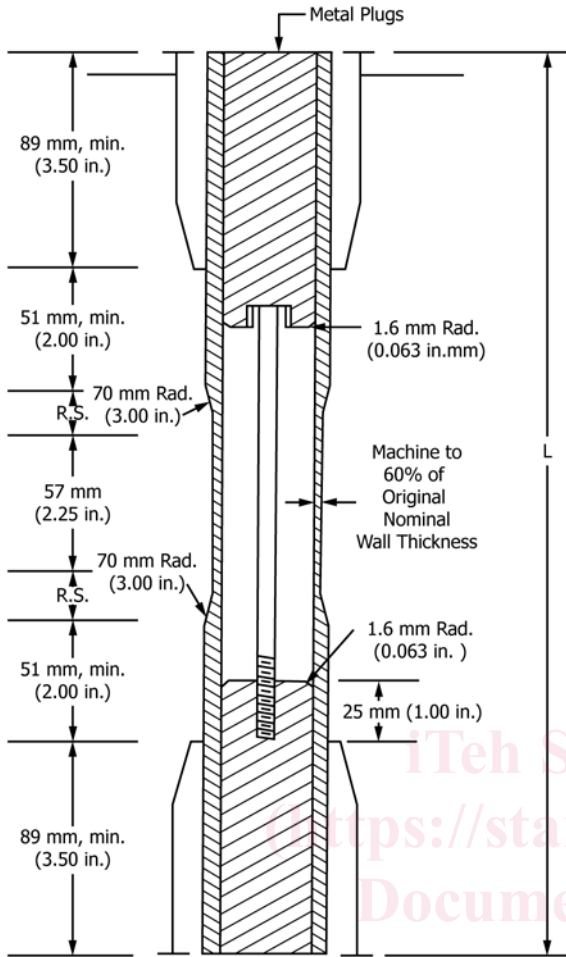

FIG. 1 Tension Test Specimens for Sheet, Plate, and Molded Plastics





NOTE 9—Specimens prepared by injection molding may have different tensile properties than specimens prepared by machining or die-cutting because of the orientation induced. This effect may be more pronounced in specimens with narrow sections.

6.2 *Rigid Tubes*—The test specimen for rigid tubes shall be as shown in Fig. 2. The length, *L*, shall be as shown in the table in Fig. 2. A groove shall be machined around the outside of the specimen at the center of its length so that the wall section after machining shall be 60 % of the original nominal wall thickness. This groove shall consist of a straight section 57.2 mm (2.25 in.) in length with a radius of 76 mm (3 in.) at each end joining it to the outside diameter. Steel or brass plugs having diameters such that they will fit snugly inside the tube and having a length equal to the full jaw length plus 25 mm (1 in.) shall be placed in the ends of the specimens to prevent crushing. They can be located conveniently in the tube by separating and supporting them on a threaded metal rod. Details of plugs and test assembly are shown in Fig. 2.

6.3 *Rigid Rods*—The test specimen for rigid rods shall be as shown in Fig. 3. The length, *L*, shall be as shown in the table in Fig. 3. A groove shall be machined around the specimen at the center of its length so that the diameter of the machined portion shall be 60 % of the original nominal diameter. This groove shall consist of a straight section 57.2 mm (2.25 in.) in length with a radius of 76 mm (3 in.) at each end joining it to the outside diameter.

6.4 All surfaces of the specimen shall be free of visible flaws, scratches, or imperfections. Marks left by coarse machining operations shall be carefully removed with a fine file or abrasive, and the filed surfaces shall then be smoothed with abrasive paper (No. 00 or finer). The finishing sanding strokes shall be made in a direction parallel to the long axis of the test specimen. All flash shall be removed from a molded specimen, taking great care not to disturb the molded surfaces. In machining a specimen, undercuts that would exceed the dimensional tolerances shown in Fig. 1 shall be scrupulously avoided. Care shall also be taken to avoid other common machining errors.

6.5 If it is necessary to place gage marks on the specimen, this shall be done with a wax crayon or India ink that will not affect the material being tested. Gage marks shall not be scratched, punched, or impressed on the specimen.

6.6 When testing materials that are suspected of anisotropy, duplicate sets of test specimens shall be prepared, having their long axes respectively parallel with, and normal to, the suspected direction of anisotropy.

7. Number of Test Specimens

7.1 Test at least five specimens for each sample in the case of isotropic materials.

7.2 For anisotropic materials, when applicable, test five specimens, normal to, and five parallel with, the principal axis of anisotropy.

7.3 Discard specimens that break at some flaw, or that break outside of the narrow cross-sectional test section (Fig. 1, dimension “L”), and make retests, unless such flaws constitute a variable to be studied.

DIMENSIONS OF TUBE SPECIMENS

Nominal Wall Thickness	Length of Radial Sections, 2R.S.	Total Calculated Minimum Length of Specimen	Standard Length, <i>L</i> , of Specimen to Be Used for 89-mm (3.5-in.) Jaws <sup>4</sup>
			mm (in.)
0.79 (1/32)	13.9 (0.547)	350 (13.80)	381 (15)
1.2 (3/64)	17.0 (0.670)	354 (13.92)	381 (15)
1.6 (1/16)	19.6 (0.773)	356 (14.02)	381 (15)
2.4 (3/32)	24.0 (0.946)	361 (14.20)	381 (15)
3.2 (1/8)	27.7 (1.091)	364 (14.34)	381 (15)
4.8 (3/16)	33.9 (1.333)	370 (14.58)	381 (15)
6.4 (1/4)	39.0 (1.536)	376 (14.79)	400 (15.75)
7.9 (5/16)	43.5 (1.714)	380 (14.96)	400 (15.75)
9.5 (3/8)	47.6 (1.873)	384 (15.12)	400 (15.75)
11.1 (7/16)	51.3 (2.019)	388 (15.27)	400 (15.75)
12.7 (1/2)	54.7 (2.154)	391 (15.40)	419 (16.5)

<sup>4</sup>For jaws greater than 89 mm (3.5 in.), the standard length shall be increased by twice the length of the jaws minus 178 mm (7 in.). The standard length permits a slippage of approximately 6.4 to 12.7 mm (0.25 to 0.50 in.) in each jaw while maintaining the maximum length of the jaw grip.

FIG. 2 Diagram Showing Location of Tube Tension Test Specimens in Testing Machine

with the reinforcement constitutes a variable being studied.

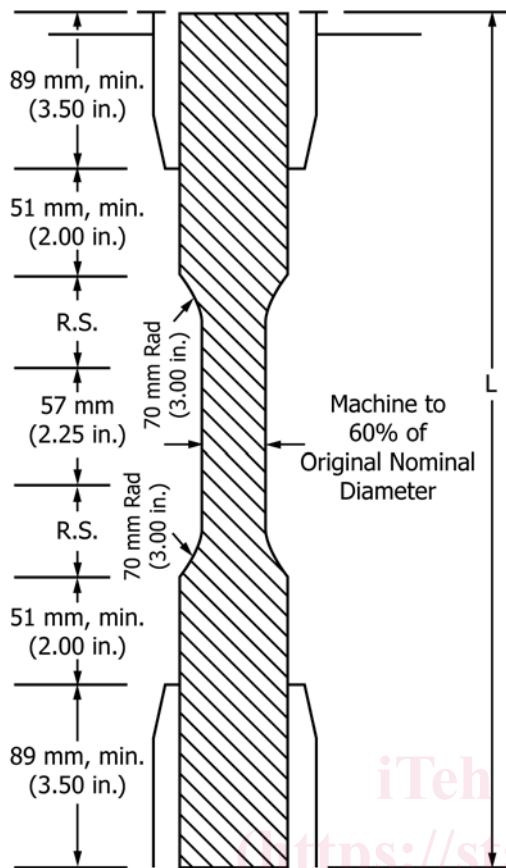

DIMENSIONS OF ROD SPECIMENS

Nominal Diameter	Length of Radial Sections, 2R.S.	Total Calculated Minimum Length of Specimen	Standard Length, L, of Specimen to Be Used for 89-mm (3.5-in.) Jaws <sup>A</sup>
3.2 (1/8)	19.6 (0.773)	356 (14.02)	381 (15)
4.7 (1/16)	24.0 (0.946)	361 (14.20)	381 (15)
6.4 (1/4)	27.7 (1.091)	364 (14.34)	381 (15)
9.5 (3/8)	33.9 (1.333)	370 (14.58)	381 (15)
12.7 (1/2)	39.0 (1.536)	376 (14.79)	400 (15.75)
15.9 (5/8)	43.5 (1.714)	380 (14.96)	400 (15.75)
19.0 (3/4)	47.6 (1.873)	384 (15.12)	400 (15.75)
22.2 (7/8)	51.5 (2.019)	388 (15.27)	400 (15.75)
25.4 (1)	54.7 (2.154)	391 (15.40)	419 (16.5)
31.8 (1 1/4)	60.9 (2.398)	398 (15.65)	419 (16.5)
38.1 (1 1/2)	66.4 (2.615)	403 (15.87)	419 (16.5)
42.5 (1 3/4)	71.4 (2.812)	408 (16.06)	419 (16.5)
50.8 (2)	76.0 (2.993)	412 (16.24)	432 (17)

<sup>A</sup>For jaws greater than 89 mm (3.5 in.), the standard length shall be increased by twice the length of the jaws minus 178 mm (7 in.). The standard length permits a slippage of approximately 6.4 to 12.7 mm (0.25 to 0.50 in.) in each jaw while maintaining the maximum length of the jaw grip.

FIG. 3 Diagram Showing Location of Rod Tension Test Specimen in Testing Machine

NOTE 10—Before testing, all transparent specimens should be inspected in a polariscope. Those which show atypical or concentrated strain patterns should be rejected, unless the effects of these residual strains constitute a variable to be studied.

### 8. Speed of Testing

8.1 Speed of testing shall be the relative rate of motion of the grips or test fixtures during the test. The rate of motion of the driven grip or fixture when the testing machine is running idle may be used, if it can be shown that the resulting speed of testing is within the limits of variation allowed.

8.2 Choose the speed of testing from Table 1. Determine this chosen speed of testing by the specification for the material being tested, or by agreement between those concerned. When the speed is not specified, use the lowest speed shown in Table 1 for the specimen geometry being used, which gives rupture within 0.5 to 5-min testing time.

8.3 Make modulus determinations at the speed selected for the other tensile properties when the recorder response and resolution are adequate.

### 9. Conditioning

9.1 *Conditioning*—Condition the test specimens in accordance with Procedure A of Practice D618, unless otherwise specified by contract or the relevant ASTM material specification. Conditioning time is specified as a minimum. Temperature and humidity tolerances shall be in accordance with Section 7 of Practice D618 unless specified differently by contract or material specification.

9.2 *Test Conditions*—Conduct the tests at the same temperature and humidity used for conditioning with tolerances in accordance with Section 7 of Practice D618, unless otherwise specified by contract or the relevant ASTM material specification.

### 10. Procedure

10.1 Measure the width and thickness of each specimen to the nearest 0.025 mm (0.001 in.) using the applicable test methods in D5947.

TABLE 1 Designations for Speed of Testing<sup>A</sup>

Classification <sup>B</sup>	Specimen Type	Speed of Testing, mm/min (in./min)	Nominal Strain <sup>C</sup> Rate at Start of Test, mm/mm·min (in./in·min)
Rigid and Semirigid	I, II, III rods and tubes	5 (0.2) ± 25 %	0.1
		50 (2) ± 10 %	1
		500 (20) ± 10 %	10
		5 (0.2) ± 25 %	0.15
		50 (2) ± 10 %	1.5
Nonrigid	IV	500 (20) ± 10 %	15
		1 (0.05) ± 25 %	0.1
		10 (0.5) ± 25 %	1
		100 (5) ± 25 %	10
		50 (2) ± 10 %	1
Nonrigid	III	500 (20) ± 10 %	10
		50 (2) ± 10 %	1.5
		500 (20) ± 10 %	15

<sup>A</sup>Select the lowest speed that produces rupture in 0.5 to 5 min for the specimen geometry being used (see 8.2).

<sup>B</sup>See Terminology D883 for definitions.

<sup>C</sup>The initial rate of straining cannot be calculated exactly for dumbbell-shaped specimens because of extension, both in the reduced section outside the gage length and in the fillets. This initial strain rate can be measured from the initial slope of the tensile strain-versus-time diagram.

10.1.1 Measure the width and thickness of flat specimens at the center of each specimen and within 5 mm of each end of the gage length.

10.1.2 For injection molded specimens, the actual measurement of only one specimen from each sample will suffice when it has previously been demonstrated that the specimen-to-specimen variation in width and thickness is less than 1 %.

10.1.3 For thin sheeting, including film less than 1.0 mm (0.04 in.), take the width of specimens produced by a Type IV die as the distance between the cutting edges of the die in the narrow section. For all other specimens, measure the actual width of the center portion of the specimen to be tested, unless it can be shown that the actual width of the specimen is the same as that of the die within the specimen dimension tolerances given in Fig. 1.

10.1.4 Measure the diameter of rod specimens, and the inside and outside diameters of tube specimens, to the nearest 0.025 mm (0.001 in.) at a minimum of two points 90° apart; make these measurements along the groove for specimens so constructed. Use plugs in testing tube specimens, as shown in Fig. 2.

10.2 Place the specimen in the grips of the testing machine, taking care to align the long axis of the specimen and the grips with an imaginary line joining the points of attachment of the grips to the machine. The distance between the ends of the gripping surfaces, when using flat specimens, shall be as indicated in Fig. 1. On tube and rod specimens, the location for the grips shall be as shown in Fig. 2 and Fig. 3. Tighten the grips evenly and firmly to the degree necessary to prevent slippage of the specimen during the test, but not to the point where the specimen would be crushed.

10.3 Attach the extension indicator. When modulus is being determined, a Class B-2 or better extensometer is required (see 5.2.1).

NOTE 11—Modulus of materials is determined from the slope of the linear portion of the stress-strain curve. For most plastics, this linear portion is very small, occurs very rapidly, and must be recorded automatically. The change in jaw separation is never to be used for calculating modulus or elongation.

10.4 Set the speed of testing at the proper rate as required in Section 8, and start the machine.

10.5 Record the load-extension curve of the specimen.

10.6 Record the load and extension at the yield point (if one exists) and the load and extension at the moment of rupture.

NOTE 12—If it is desired to measure both modulus and failure properties (yield or break, or both), it may be necessary, in the case of highly extensible materials, to run two independent tests. The high magnification extensometer normally used to determine properties up to the yield point may not be suitable for tests involving high extensibility. If allowed to remain attached to the specimen, the extensometer could be permanently damaged. A broad-range incremental extensometer or hand-rule technique may be needed when such materials are taken to rupture.

## 11. Calculation

11.1 Toe compensation shall be made in accordance with Annex A1, unless it can be shown that the toe region of the curve is not due to the take-up of slack, seating of the specimen, or other artifact, but rather is an authentic material response.

11.2 *Tensile Strength*—Calculate the tensile strength by dividing the maximum load sustained by the specimen in newtons (pounds-force) by the average original cross-sectional area in the gage length segment of the specimen in square metres (square inches). Express the result in pascals (pounds-force per square inch) and report it to three significant figures as tensile strength at yield or tensile strength at break, whichever term is applicable. When a nominal yield or break load less than the maximum is present and applicable, it is often desirable to also calculate, in a similar manner, the corresponding tensile stress at yield or tensile stress at break and report it to three significant figures (see Note A2.8).

11.3 Elongation values are valid and are reported in cases where uniformity of deformation within the specimen gage length is present. Elongation values are quantitatively relevant and appropriate for engineering design. When non-uniform deformation (such as necking) occurs within the specimen gage length nominal strain values are reported. Nominal strain values are of qualitative utility only.

11.3.1 *Percent Elongation*—Percent elongation is the change in gage length relative to the original specimen gage length, expressed as a percent. Percent elongation is calculated using the apparatus described in 5.2.

11.3.1.1 *Percent Elongation at Yield*—Calculate the percent elongation at yield by reading the extension (change in gage length) at the yield point. Divide that extension by the original gage length and multiply by 100.

11.3.1.2 *Percent Elongation at Break*—Calculate the percent elongation at break by reading the extension (change in gage length) at the point of specimen rupture. Divide that extension by the original gage length and multiply by 100.

11.3.2 *Nominal Strain*—Nominal strain is the change in grip separation relative to the original grip separation expressed as a percent. Nominal strain is calculated using the apparatus described in 5.1.7.

11.3.2.1 *Nominal strain at break*—Calculate the nominal strain at break by reading the extension (change in grip separation) at the point of rupture. Divide that extension by the original grip separation and multiply by 100.

11.4 *Modulus of Elasticity*—Calculate the modulus of elasticity by extending the initial linear portion of the load-extension curve and dividing the difference in stress corresponding to any segment of section on this straight line by the corresponding difference in strain. All elastic modulus values shall be computed using the average original cross-sectional area in the gage length segment of the specimen in the calculations. The result shall be expressed in pascals (pounds-force per square inch) and reported to three significant figures.

11.5 *Secant Modulus*—At a designated strain, this shall be calculated by dividing the corresponding stress (nominal) by the designated strain. Elastic modulus values are preferable and shall be calculated whenever possible. However, for materials where no proportionality is evident, the secant value shall be calculated. Draw the tangent as directed in A1.3 and Fig. A1.2, and mark off the designated strain from the yield point where the tangent line goes through zero stress. The stress to be used