



Designation: ~~F1898~~—15 F1898 – 22

An American National Standard

Standard Specification for Helmets for Non-Motorized Wheeled Vehicles Used by Infants and Toddlers¹

This standard is issued under the fixed designation F1898; the number immediately following the designation indicates the year of original adoption or, in the case of revision, the year of last revision. A number in parentheses indicates the year of last reapproval. A superscript epsilon (ϵ) indicates an editorial change since the last revision or reapproval.

1. Scope

1.1 This specification covers performance requirements for helmets manufactured for use by infants and toddlers as passengers or operators of nonmotorized vehicles intended for their use. This specification recognizes the desirability of lightweight construction and ventilation; however, it is a performance standard and is not intended to restrict design.

1.2 All testing and requirements of this specification shall be in accordance with Test Methods ~~F1446~~ except as noted.

1.3 Partial utilization of this standard is prohibited. Any statement of compliance with this specification must be a certification that the product meets all of the requirements of this specification in their entirety. A product that fails to meet any one of the requirements of this specification is considered to have failed this standard, and should not be sold with any indication that it meets parts of this standard.

1.4 Headgear that complies with this and other standards may proclaim uses as described in those standards as certified by the manufacturer.

1.5 This standard is subject to revision at any time by ASTM. It must be reviewed every five years and if not revised either reapproved or withdrawn. References to the standard must include the version date. No references to a version that has been replaced or withdrawn shall be placed on any product or its packaging manufactured more than 24 months after the effective revision or withdrawal date. Go to astm.org to verify the latest version of this standard.

1.6 The values stated in SI units are to be regarded as standard. No other units of measurement are included in this standard.

1.7 *This standard does not purport to address all of the safety concerns, if any, associated with its use. It is the responsibility of the user of this standard to establish appropriate safety, health, and environmental practices and determine the applicability of regulatory limitations prior to use.*

1.8 *This international standard was developed in accordance with internationally recognized principles on standardization established in the Decision on Principles for the Development of International Standards, Guides and Recommendations issued by the World Trade Organization Technical Barriers to Trade (TBT) Committee.*

¹ This specification is under the jurisdiction of ASTM Committee F08 on Sports Equipment, Playing Surfaces, and Facilities and is the direct responsibility of Subcommittee F08.53 on Headgear and Helmets.

Current edition approved April 1, 2015; June 15, 2022. Published April 2015; July 2022. Originally approved in 1998. Last previous edition approved in 2015 as ~~F1898—08~~ (2015) F1898 – 15. DOI: 10.1520/F1898-15.10.1520/F1898-22.

2. Referenced Documents

2.1 ASTM Standards:²

F1446 Test Methods for Equipment and Procedures Used in Evaluating the Performance Characteristics of Protective Headgear

3. Labels and Warnings

3.1 In addition to the labeling requirements outlined in Test Methods F1446, the helmet shall have the words “For use by infants and toddlers when riding non-motorized wheeled vehicles intended for their use” inscribed on one of the interior permanent labels.

4. Marking the Test Line

4.1 The test line is shown in Fig. 1 and shall be marked in accordance with Test Methods F1446.

5. Conditioning and Number of Samples

5.1 Four helmets of each model and size are required for testing.

5.2 Conditioning of test samples is described in Test Methods F1446.

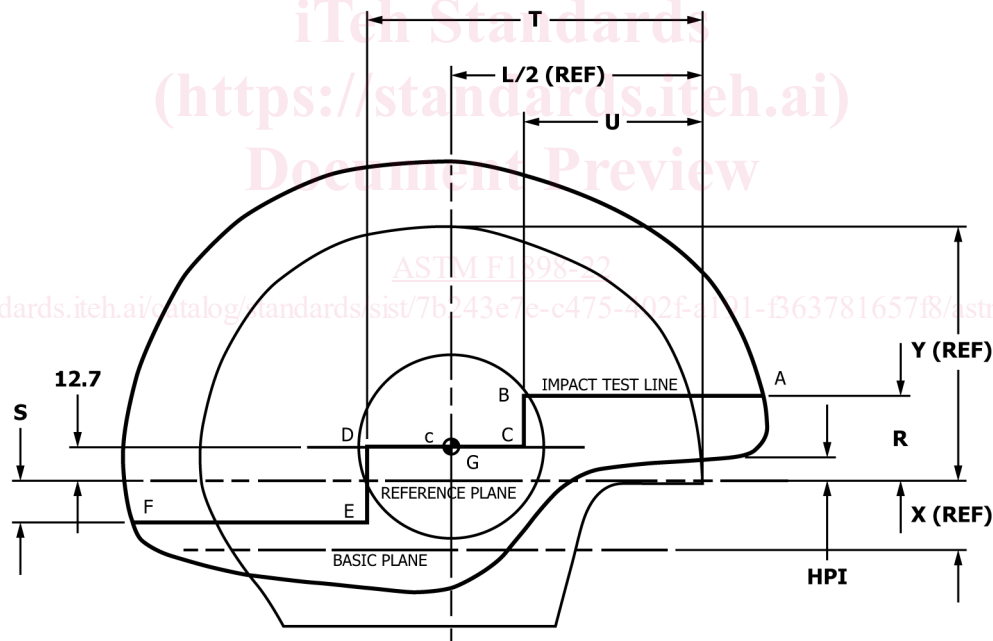

Headform Size	Dimension						
	X	L/2	Y	R	S	T	U
A	24.0	88.0	89.7	30.0	15.0	118.0	63.0
C	25.0	91.0	92.7	31.0	15.5	122.0	65.0
E	26.0	94.5	96.0	32.0	16.0	126.5	67.5

NOTE 1—This test line drawing shows test lines on helmet rather than on headform and uses dimensional nomenclature R, S, T, U as in other drawings (formerly a, b, c,...). The position of the lines on this drawing has not changed except that they are a bit more stringent because of the angle of projection from the c/g, which is the center of the ball about which the headform pivots to align an impact site with the anvil.

FIG. 1 Marking the Test Line

² For referenced ASTM standards, visit the ASTM website, www.astm.org, or contact ASTM Customer Service at service@astm.org. For Annual Book of ASTM Standards volume information, refer to the standard’s Document Summary page on the ASTM website.

6. Headforms

6.1 Headforms to be used in this specification are sizes A, C, and E according to Test Methods F1446, using the variable mass drop assembly configuration. The appropriate size headform shall be selected in accordance with Test Methods F1446 for the helmet to be tested.

6.2 The headform center of gravity specified in Appendix X1 of Test Methods F1446 will be allowed an additional tolerance in the X-axis. The tolerance allows the location of the center of gravity to lie between -6.5 mm and 40 mm of the center of the ball socket (positive X is toward the monorail where applicable).

7. Peripheral Vision Requirement

7.1 The peripheral vision requirements shall be as specified in Test Methods F1446.

8. Retention System Testing

8.1 Retention system tests will be performed before impact testing. The retention system shall be tested in accordance with Test Methods F1446 using a 7-kg \pm 5 % support assembly.

8.2 The stability (roll-off) test will be performed using a 4-kg drop mass falling a distance of 0.6 m. The stability test will be performed on the ambient helmet.

8.3 The retention system shall remain intact and the helmet must remain on the headform.

8.4 The dynamic strength test will be performed using a 4-kg drop mass falling a distance of 0.6 m. The dynamic strength test will be performed on the cold, wet, and hot helmets.

8.5 The retention system shall remain intact without elongating more than 30 mm.

9. Anvils and Impact Velocities

9.1 Anvils to be used for impact tests in this specification are the flat, hemispherical and curbstone anvils described in Test Methods F1446.

9.2 The helmet shall be dropped onto the flat anvil to achieve an impact velocity of 6.2 m/s \pm 3 % (corresponding to a theoretical drop height of 2.0 m).

9.3 The helmet shall be dropped onto the hemispherical and curbstone anvils to achieve an impact velocity of 4.8 m/s \pm 3 % (corresponding to a theoretical drop height of 1.2 m).

10. Impact Sites

10.1 Impact tests shall be performed after retention testing.

10.2 The center of the impact can be anywhere on or above the test line shown in Fig. 1.

11. Impacting Schedule

11.1 Each hot, cold, or wet helmet shall receive a single impact at not more than four sites.

11.2 Impacts shall be separated by a minimum of 120 mm.

11.3 Any combination of flat and hemispherical anvils can be applied to the hot, cold and wet helmets.

11.4 The ambient helmet shall receive one impact using the curbstone anvil.