



Designation: D4884/D4884M – 22

# Standard Test Method for Strength of Sewn or Bonded Seams of Geotextiles<sup>1</sup>

This standard is issued under the fixed designation D4884/D4884M; the number immediately following the designation indicates the year of original adoption or, in the case of revision, the year of last revision. A number in parentheses indicates the year of last reapproval. A superscript epsilon ( $\epsilon$ ) indicates an editorial change since the last revision or reapproval.

## 1. Scope

1.1 This test method covers the determination of the factory and field seam strength of geotextiles, using a wide specimen and wet and dry specimens.

1.2 The long-term performance of a seaming technique is not addressed by this test method. This test method will provide data to indicate the short-term seam strength that can be achieved for each particular geotextile and seam assembly construction. To assess the long-term performance of a seaming technique, it is possible to use Practice D6389, using this test method to determine the anticipated strength reduction in the initial, short-term wide-width tensile strength (Test Method D4595) results.

1.3 The values stated in either SI units or inch-pound units are to be regarded separately as standard. The values stated in each system are not necessarily exact equivalents; therefore, to ensure conformance with the standard, each system shall be used independently of the other, and values from the two systems shall not be combined.

1.4 *This standard does not purport to address all of the safety concerns, if any, associated with its use. It is the responsibility of the user of this standard to establish appropriate safety, health, and environmental practices and determine the applicability of regulatory limitations prior to use.*

1.5 *This international standard was developed in accordance with internationally recognized principles on standardization established in the Decision on Principles for the Development of International Standards, Guides and Recommendations issued by the World Trade Organization Technical Barriers to Trade (TBT) Committee.*

## 2. Referenced Documents

2.1 *ASTM Standards:*<sup>2</sup>

<sup>1</sup> This test method is under the jurisdiction of ASTM Committee D35 on Geosynthetics and is the direct responsibility of Subcommittee D35.01 on Mechanical Properties.

Current edition approved July 1, 2022. Published August 2022. Originally approved in 1989. Last previous edition approved in 2014 as D4884/D4884M – 14a. DOI: 10.1520/D4884\_D4884M-22.

<sup>2</sup> For referenced ASTM standards, visit the ASTM website, www.astm.org, or contact ASTM Customer Service at service@astm.org. For *Annual Book of ASTM Standards* volume information, refer to the standard's Document Summary page on the ASTM website.

D76/D76M Specification for Tensile Testing Machines for Textiles

D1776/D1776M Practice for Conditioning and Testing Textiles

D1777 Test Method for Thickness of Textile Materials

D4439 Terminology for Geosynthetics

D4595 Test Method for Tensile Properties of Geotextiles by the Wide-Width Strip Method

D6389 Practice for Tests to Evaluate the Chemical Resistance of Geotextiles to Liquids

E178 Practice for Dealing With Outlying Observations

E691 Practice for Conducting an Interlaboratory Study to Determine the Precision of a Test Method

2.2 *Federal Standard:*<sup>3</sup>

Fed. Std. No. 751a Stitches, Seams, and Stitchings

## 3. Terminology

3.1 For definitions of terms relating to geotextiles, refer to Terminology D4439.

3.2 *Definitions of Terms Specific to This Standard:*

3.2.1 *adhered seam, n*—in geotextiles, a seam made by the application of an adhesive.

3.2.2 *seam weld, n*—the process by which a seam is formed through the thermal bonding of separate layers of geotextile.

3.2.3 *selvage, n*—the woven edge portion of a geotextile parallel to the machine direction.

3.2.4 *sewing thread, n*—a flexible, small diameter yarn or strand, usually treated with a surface coating, or lubricant, or both, intended to be used to stitch one or more pieces of material or an object to a material.

3.2.5 *stitch, n*—the repeated unit formed by the sewing thread in the production of seams in a sewn geotextile (see Fed. Std. No. 751a).

## 4. Summary of Test Method

4.1 Material is divided into lots and a lot sample taken as described in an applicable material specification, or as agreed upon between the purchaser and the supplier.

<sup>3</sup> Available from DLA Document Services, Building 4/D, 700 Robbins Ave., Philadelphia, PA 19111-5094, http://quicksearch.dla.mil.

4.2 Specimens with seams are prepared from the samples per applicable specification or prior agreement between the purchaser and the supplier; otherwise, prepare at least six test specimens.

4.3 A specimen is placed in the test machine with a seam 200 mm [8 in.] wide being gripped on both sides across the entire width in the clamps depending on the type of seam.

4.4 The test specimen is subjected to a longitudinal (perpendicular) force at a prescribed rate of extension until the seam or geotextile ruptures.

4.5 Test specimens are evaluated for how they failed and specimens that are judged invalid are removed from the analysis.

## 5. Significance and Use

5.1 As explained in Test Method **D4595**, narrow geotextile specimens demonstrate the tendency to contract (neck down) in the gauge area when under stress. The wider width specimen will minimize this phenomenon in seams during strength testing. The results achieved in this test method can more accurately correlate to the seam strength values anticipated in the field.

5.2 This test method can be used to measure the seam strength of geotextiles from the factory or field, and may also be used for acceptance testing of commercial shipments of geotextiles.

5.3 This test method can be used to help determine seam design engineering for the geotextiles being evaluated, as well as comparing wet-conditioned specimens with dry specimen results.

5.4 This test method is not intended to address long-term performance of a seam, nor any of its components such as the thread or the adhesive. However, it can be used as an index value to monitor the behavior of a seam exposed to any particular exposure, in example as part of an effort to assess its long-term performance.

## 6. Apparatus

6.1 *Tensile Testing Machine*, must be of the constant-rate-of-extension (CRE) type, conforming to Specification **D76/D76M** and equipped with a recorder having an adequate pen response or interfaced computer to record the load elongation curve. The machine must be capable of being set to a rate of extension of  $10 \pm 3$  %/min.

6.2 *Clamps*—The clamps shall be wide enough to grip the entire width of the specimen and have the appropriate clamping power to hold the test specimen in place without crushing (damaging) the geotextile.

6.2.1 Caution must be taken to ensure that the type of clamp used is adequate for the seam strength being measured.

6.3 *Size of Jaw Faces*—Each clamp shall have a clamping face wider than the width of the specimen, typically 225 mm [8.86 in.] or larger, and a minimum of 50 mm [2 in.] in the direction of the applied force. The size of jaw faces does not apply if roller clamps are used.

## 7. Sampling and Specimens

7.1 The evaluation of field seams and factory seams will be made by taking samples at the stipulated intervals directed in **Table 1** unless otherwise stated.

**TABLE 1 Seam Quality Control Sampling Requirements**

Total Length of Field <sup>A</sup> Seams for Project, m [yd]	Sample Interval <sup>B</sup> Requirements, m [yd]
Up to 10 000 [Up to 11 000]	1000 [1100]
10 001 to 150 000 [11 000 to 165 000]	1500 [1666]
150 000 and up [165 000 and up]	2000 [2200]

<sup>A</sup> Total length of field seams for project is the sum of all machine direction and cross-machine direction seams required to effect installation of geotextile(s).

<sup>B</sup> Samples will be taken at stipulated intervals along the total length of the field seams. The number of such intervals will be rounded to the next higher whole number.

NOTE 1—To prevent the unnecessary waste of geotextile or impede the installation, it should be agreed upon between the supplier and the purchaser that all seam samples can be taken from alternate sides of panels at or near the end of the rolls.

7.2 The lengthwise direction of these swatches should be parallel to the direction of the seam, either in the machine or cross-machine direction.

7.2.1 It will be necessary to cut additional swatches for both wet and conditioned tests to be performed.

7.3 Prepare test specimens as specified in **7.6.2**.

7.4 *Division into Lots and Lot Sample*—Divide the material into lots and take a lot sample as described in an applicable material specification, or as agreed upon between the purchaser and the supplier. In the absence of an applicable material specification or prior agreement between the purchaser and the supplier, sampling and testing intervals should be agreed upon between the purchaser and the supplier.

7.4.1 When the installation project requires that seams are made in both the machine and cross-machine directions, the number of samples and the subsequent specimens will increase proportionately.

7.5 *Laboratory Samples*—As a laboratory sample, cut a minimum of two swatches of geotextile from each of the lot units selected for testing. The swatches must be long and large enough to permit seaming and selection of representative sections of seams for specimen preparation, such as, a minimum of 2000 mm [79 in.] in length and a minimum of 300 mm [12 in.] in width. The lengthwise direction of these swatches must be cut from opposite ends and opposite sides of the lot sample rolls and should be parallel to the direction in which the seam will be made.

7.5.1 When seams are made in both the machine and cross-machine direction, it is suggested that some type of special color identification marking be used to distinguish one from the other.

7.5.2 These swatches are then joined using the best seam engineering techniques determined by the purchaser and the supplier to achieve seam interaction.

7.5.3 It will be necessary to cut a sufficient number of swatches for both wet and conditioned tests.

7.6 Test Specimens:

7.6.1 Number of Specimens—In the absence of an applicable specification or prior agreement between the purchaser and the supplier, prepare at least six test specimens from the laboratory samples.

7.6.2 Test Specimen Size—Prepare test specimens from the laboratory sample. Each specimen should be approximately 250 mm [10 in.] wide with a stitch line in the center for sewn seams or approximately 200 mm [8 in.] wide with the seam weld in the center for thermally bonded or adhered seams running parallel to either the machine or cross-machine directions as shown in Fig. 1(a) for sewn seams, Fig. 1(b) for thermally bonded seams, or Fig. 1(c) for adhered seams.

7.6.2.1 Cut this wider specimen for sewn seams as shown in Fig. 1(a) to achieve a final test specimen width of 200 mm [8 in.]. When removing the shaded area from a specimen as shown in Fig. 1(a), the angles between the 25 mm [1 in.] extensions which are parallel to the seam and that section of the specimen having a finished width of 200 mm [8 in.] is 90°.

7.6.2.2 For some seaming patterns, cutting the thread may lead to a loss of the integrity of the seam, and thus to an underestimation of the seam strength. For these patterns, some means shall be used to lock the thread in place, such as using glue, or mechanically locking the thread on both ends of the seam by unsewing the seam over a maximum length of 25 mm [1 in.], without damaging the sewing thread, in order to have at least 200 mm [8 in.] of intact seam centered in the axis of the specimen. Both upper and lower threads of the seam shall then be tied together to avoid any further modification to the structure of the stitch during the test.

8. Conditioning

8.1 Bring the specimens to moisture equilibrium in the atmosphere for testing geotextiles. Equilibrium is considered to have been reached when the increase in mass of the specimen in successive weighings made at intervals of not less than 2 h does not exceed 0.1 % of the mass of the specimen. Unless the purchaser and the supplier agree otherwise, bring the test specimens to moisture equilibrium starting with the condition in which they were received.

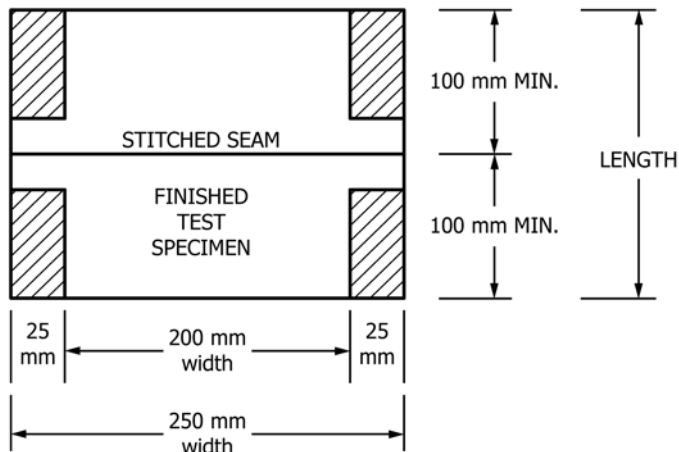

FIG. 1 (a) Test Specimen Preparation for Sewn Seam (Front View)

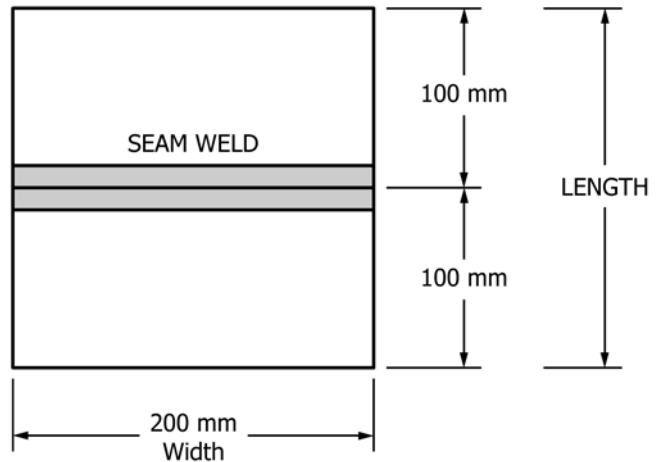
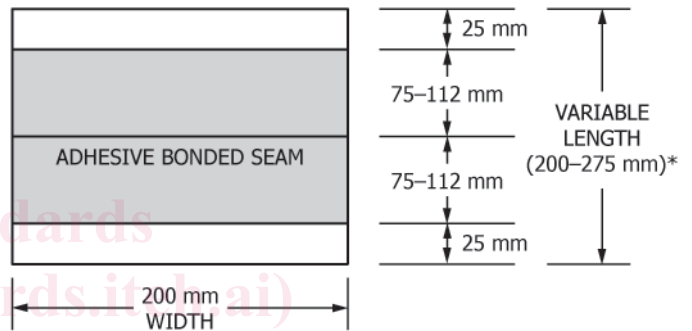

FIG. 1 (b) Test Specimen Preparation for Thermally Bonded Seam (Front View) (continued)



\*Where adhered seam overlap is 150 mm [6 in.], adhered seam specimen length is 200 mm [8 in.]; where adhered seam overlap is 225 mm [9 in.], adhered seam specimen length is 275 mm [11 in.].

FIG. 1 (c) Test Specimen Preparation for Adhesive Bonded Seam (Front View) (continued)

8.1.1 Certain fibers may exhibit slow moisture equalization rates when received in a wet condition. When this is known, the purchaser and the supplier may agree to use a preconditioning cycle as specified in Practice D1776/D1776M.

NOTE 2—It is recognized that, in practice, geotextile materials are frequently not weighted to determine when moisture equilibrium has been reached. While such a procedure cannot be accepted in cases of dispute, it may be sufficient in routine testing to expose the material to the standard atmosphere for testing for a reasonable period of time before the specimens are tested. A time of at least 24 h has been found acceptable in most cases.

9. Wet Testing (optional)

9.1 If wet field conditions are expected, one test could be specified to be performed with a wet-conditioned specimen and compared with dry specimen results. If significant variations exist, wet conditioning should be considered for all test specimens by the supplier and the purchaser.

9.1.1 Specimens to be tested in the wet condition must be immersed in water maintained at a temperature of 21 ± 2 °C [70 ± 4 °F]. In the absence of an applicable conditioning

specification or prior agreement between the purchaser and the supplier, immersion of 24 h will be required to effect complete wet conditioning.

9.1.1.1 It may be necessary or advisable to add 0.05 % of a nonionic neutral wetting agent to the water to obtain thorough wetting.

9.1.1.2 A test of any immersed specimen must be completed within 20 min after removal from the water.

9.2 When conducting wet-conditioned tests of field seam specimens, it will be necessary to immerse these specimens as required in 9.1.1 to effect wetting. Perform a series of at least ten wet-conditioned tests on test specimens from the geotextile to be evaluated. Prepare the test specimens as a single group from this same production lot and assign them in equal numbers, at random, for testing.

**10. Procedure**

10.1 For All Specimens—As described in 7.6, test specimens are cut from laboratory samples to a specimen size shown in either Fig. 1(a) or Fig. 1(b).

10.1.1 With geotextile facing in the open front position as shown in Fig. 1(a) and Fig. 1(b), so that the stitch line or seam weld furthest from the selvage is clearly visible, carefully draw one parallel line on both sides of the seam, 50 mm [2 in.] from the row of stitches in a sewn seam or 50 mm [2 in.] from the edge of the seam weld width on a thermally bonded seam that is used to determine seam allowance or 25 mm [1 in.] from the edge of the seam overlap for an adhered seam. These parallel lines designate the gauge area. The seam must be centered, as much as possible, between these lines so that the seam is parallel to the clamps.

10.1.2 The length of the specimen perpendicular to the seam depends upon the type of clamps being used. It must be long enough to extend through the full length of both clamps in a manner so that the gauge length of 50 mm [2 in.] on each side of the center of the seam is not reduced (see Fig. 2(a), Fig. 2(b), and Fig. 2(c)).

10.1.3 For each test specimen of sewn seams, determine the stitch density by counting the number of stitches available over the 200 mm [8 in.] width of each test specimen, expressed in stitches per centimeter or stitches per inch.

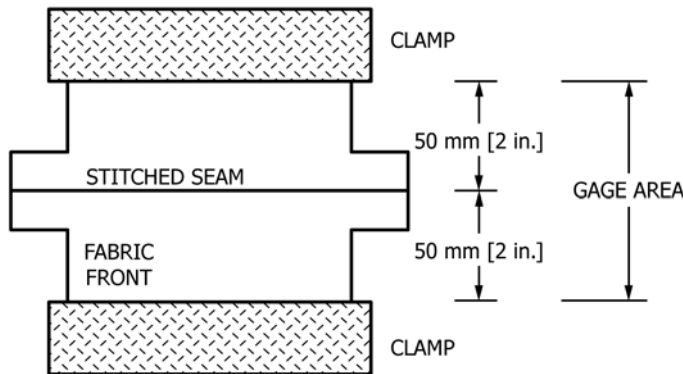

FIG. 2 (a) Placement of Generic Seam in Clamps for Sewn Seam (Front View)

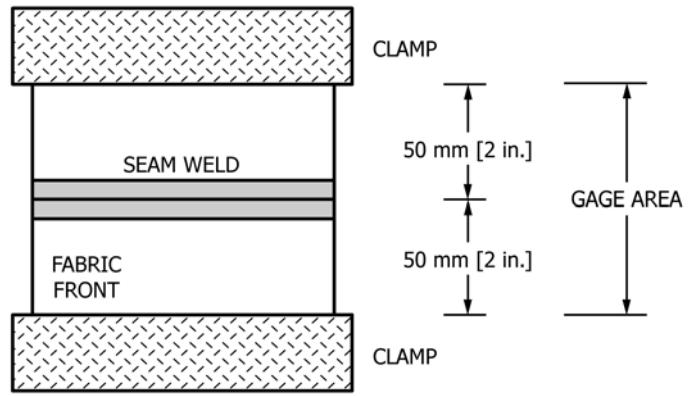

FIG. 2 (b) Placement of Generic Seam in Clamps for Thermally Bonded Seam (Front View) (continued)

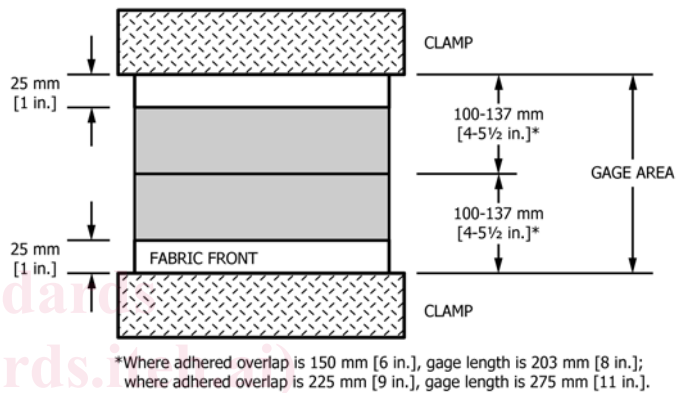

FIG. 2 (c) Placement of Generic Seam in Clamps for Adhesive Bonded Seam (Front View) (continued)

10.1.4 For adhesive and thermally bonded seams, measure the thickness in the bonded area as specified in Test Method D1777.

10.1.5 For adhesive and thermally bonded seams, measure the bonded overlap dimension.

10.2 Insertion of Specimen in Clamps—Mount the seam specimen centrally in the clamps facing in the open front position as described in 10.1.1. Do this by positioning the two lines previously drawn in 10.1.1 as close as possible to the inside edges of the lower and upper jaw with the seam centered. The seam and gauge lines must be parallel to the clamps as shown in Fig. 2(a), Fig. 2(b), and Fig. 2(c). When testing either the machine or cross-machine direction seam strength, tension on the specimen should be uniform across the width.

10.3 Measurement of Seam Strength—Start the tensile testing machine and continue the procedure until the seam or geotextile ruptures. Stop the machine and reset to the initial gauge position.

10.3.1 During application of the load to the seam specimen, observe and record the maximum force to rupture of the seam as read directly from the testing machine. Observe and record whether the seam rupture is caused by geotextile yarn rupture, sewing thread rupture, seam weld edge break, adhesive slippage, geotextile yarn slippage, tear-type geotextile yarn rupture, or a combination thereof.