



Designation: D6918 – 09 (Reapproved 2022)

Standard Test Method for Testing Vertical Strip Drains in the Crimped Condition¹

This standard is issued under the fixed designation D6918; the number immediately following the designation indicates the year of original adoption or, in the case of revision, the year of last revision. A number in parentheses indicates the year of last reapproval. A superscript epsilon (ϵ) indicates an editorial change since the last revision or reapproval.

1. Scope

1.1 This test method is a performance test that measures the effect crimping has on the ability of vertical strip drains to transmit water parallel to the plane of the drain.

1.2 This test method is applicable to all vertical strip drains.

1.3 The values stated in SI units are to be regarded as standard. No other units of measurement are included in this standard.

1.4 *This standard does not purport to address all of the safety concerns, if any, associated with its use. It is the responsibility of the user of this standard to establish appropriate safety, health, and environmental practices and determine the applicability of regulatory limitations prior to use.*

1.5 *This international standard was developed in accordance with internationally recognized principles on standardization established in the Decision on Principles for the Development of International Standards, Guides and Recommendations issued by the World Trade Organization Technical Barriers to Trade (TBT) Committee.*

2. Referenced Documents

2.1 *ASTM Standards:*²

- D4354 Practice for Sampling of Geosynthetics and Rolled Erosion Control Products (RECPs) for Testing
- D4439 Terminology for Geosynthetics

3. Terminology

3.1 *Definitions:*

3.1.1 For general geosynthetics terms used in this test method, refer to Terminology D4439.

3.2 *Definitions of Terms Specific to This Standard:*

3.2.1 *vertical strip drain, n*—a geocomposite consisting of a geotextile cover and drainage core installed vertically into soil to provide drainage for accelerated consolidation of soils.

¹ This test method is under the jurisdiction of ASTM Committee D35 on Geosynthetics and is the direct responsibility of Subcommittee D35.03 on Permeability and Filtration.

Current edition approved Aug. 1, 2022. Published August 2022. Originally approved in 2003. Last previous edition approved in 2014 as D6918 – 09 (2014). DOI: 10.1520/D6918-09R22.

² For referenced ASTM standards, visit the ASTM website, www.astm.org, or contact ASTM Customer Service at service@astm.org. For *Annual Book of ASTM Standards* volume information, refer to the standard's Document Summary page on the ASTM website.

4. Summary of Test Method

4.1 This test method presents two methods for determining the effect of a crimp forming in the vertical strip drain due to the consolidation of soils around it in the field.

4.1.1 A vertical strip drain is sealed in a waterproof membrane to prevent any water from escaping out through the geotextile during the test.

4.1.2 The sealed vertical strip drain is placed in the appropriate crimping device and water is allowed to pass through it under a constant head of water.

4.1.3 A crimp is placed on the specimen, and water allowed to pass through it under a constant head in the crimped condition.

4.1.4 The flow rate of water along the plane of the uncrimped vertical strip drain is compared to the flow rate in the crimped condition.

5. Significance and Use

5.1 This test method is considered satisfactory for the acceptance of commercial shipments of vertical strip drains.

5.1.1 In case of dispute arising from differences in reported test results when using this test method for acceptance testing of commercial shipments, the purchaser and the supplier should conduct comparative tests to determine if there is any statistical bias between their laboratories. Competent statistical assistance is recommended for the investigation of bias. As a minimum, the two parties should take a group of test specimens that as homogenous as possible, and that are from a lot of material of the type in question. The test specimens should be randomly assigned in numbers to each laboratory for testing. The average results from the two laboratories should be compared using Student's t-test for unpaired data and an acceptable probability level chosen by the two parties before the start of testing. If a bias is found, either its cause must be found and corrected, or the purchaser and the supplier must agree to interpret future test results in light of the known bias.

5.2 Vertical strip drains are installed in areas where it is desired to increase the rate of soil consolidation. It has been shown that as the soil around the vertical strip drain consolidates, a crimp may form in the vertical strip drain due to the movement of the drain in the area of soil consolidation.

5.3 This test method can be used to evaluate if there is any reduction in flow rate of water through the drain due to the

crimping, and what effect, if any, this crimping may have on the rate of consolidation of the soil.

6. Apparatus

6.1 Method A:

6.1.1 The test device must be capable of maintaining a constant head of water on the vertical strip drain being tested. The apparatus consists of a water chamber assembly, a specimen holder, and a crimping wedge, all of which are attached to a holding stand. See Figs. 1 and 2.

6.1.2 *Container*, for collecting the water as it flows through the vertical strip drain.

6.1.3 *Stopwatch or Electronic Timing Device*—A stopwatch with an accuracy level to 0.1 s, connected to the collection container, for timing the flow of water through the vertical strip drain.

6.1.4 *Blow Dryer*, used for applying heat to the heat shrink-wrap that is placed around the test specimen prior to testing.

6.2 Method B:

6.2.1 *Discharge Capacity Tester*—The discharge capacity tester may be pressured by earth pressure when the vertical strip drains are mounted vertically within the ground to serve as discharging interstitial water. The apparatus in use for the principle illustrated in Fig. 3 is used for monitoring the variation of the discharge capacity of the vertical strip drains in the event of the earth pressure.

6.2.1.1 The discharge capacity tester is mainly comprised of a sample mounting portion, a pressure controller, water supply, and a flow rate measurement portion.

6.2.1.2 The sample mounting portion must maintain all vertically mounted vertical strip drains. The length of the vertical strip drain exposed to external pressure must be 300 ± 10 mm.

6.2.1.3 The mounted sample is covered by a cylinder, and air pressure or hydraulic pressure must be applied to the

internal component of the cylinder in order to model the pressure arising from the earth mass.

6.2.1.4 The pressure controller should be provided for controlling the pressure applied to the mounted sample.

6.2.1.5 The water supply for adjusting height is required.

6.2.1.6 The flow rate measurement portion measures the amount of water passing through the mounted sample.

6.2.1.7 *Rubber Membrane*—A cylinder-shaped rubber membrane, of a thickness of 0.35 mm, and formed with synthesized rubber latex.

6.2.1.8 *Stopwatch*—See 6.1.3.

6.2.1.9 *Thermometer*—A thermometer with an accuracy level to 0.2 °C.

6.2.1.10 *Flow Meter*—An instrument capable of measuring the amount of water with an accuracy level of 10 cm³, or a gauge revised with an accuracy of 5 % for enabling the direct measurement of the flow velocity.

7. Materials

7.1 Method A:

7.1.1 *Heat Shrink Plastic Wrap*—The heat shrink plastic wrap, of the type used in homes for sealing windows from wind drafts, is used to seal the vertical strip drain so that water does not flow out through the geotextile wrap on the core. The water is to flow in a parallel plan to the fabric, along the core material of the drain.

7.1.2 *Bathtub Caulk*—The caulk is used to seal the test specimen into the water chamber assembly as directed in 12.1.2.

7.2 Method B:

7.2.1 Test Water:

7.2.1.1 Water ranging from 18 to 22 °C is used for the test water.

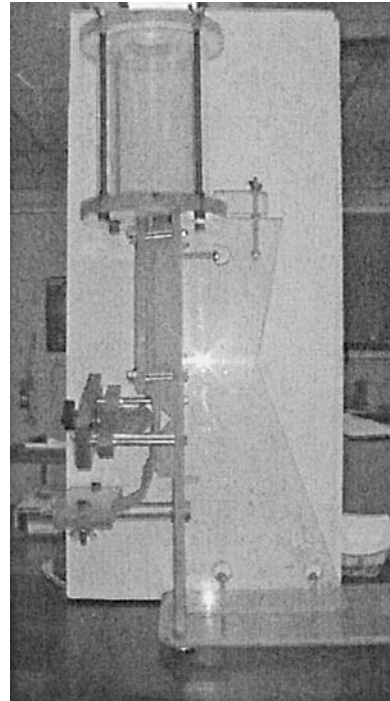

FIG. 2 Complete Crimp Test Apparatus for Method A

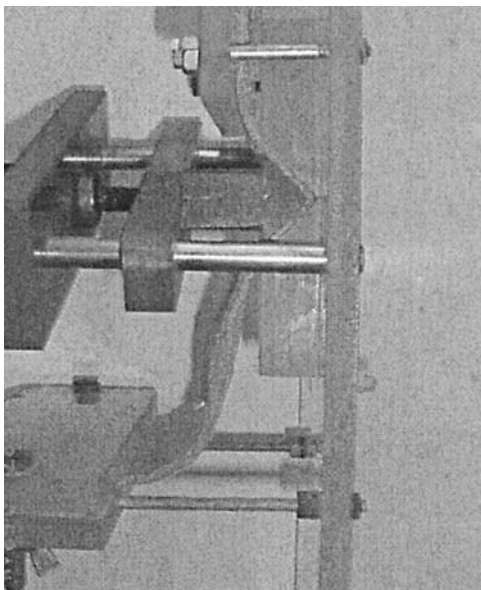

FIG. 1 Crimping Wedge for Method A

Top-view of specimen settlement

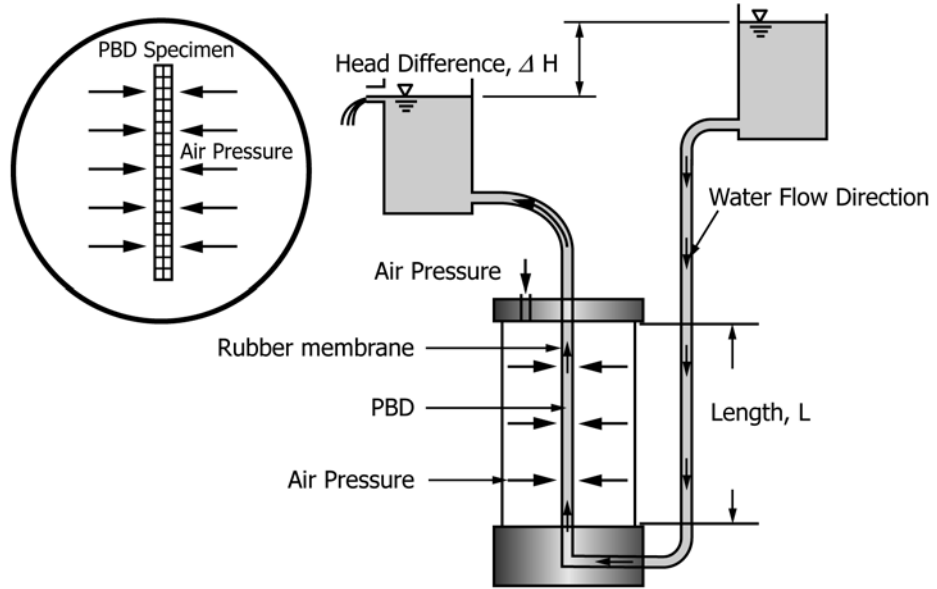

FIG. 3 Test Device for Method B

NOTE 1—The temperature correction (referring to an accompanying document A) is in relation only to streamline flow, and thus, where the flow of water is not the streamline flow, the water temperature should be maintained close to a temperature of 20 °C in order to minimize any inaccuracies caused by the inappropriate correction coefficient.

7.2.1.2 If the test water is directly provided from the water supply, air bubbles may be generated in the internal construction of the test specimens. Therefore, the test water should be provided from a distillation tank in a bubble-removed state.

7.2.1.3 Where the test water includes solids or substances apparent to the naked eye, or where the passage amount of the water is gradually reduced due to a stacked solid or substances on the test specimens, the water should be filtered.

8. Hazards

8.1 There are no known hazards, either with the materials or in performing this test.

9. Sampling, Test Specimens, and Test Units

9.1 *Division Into Lots and Lot Samples*—Divide the material into lots and take a lot sample as directed in Practice D4354. Rolls of prefabricated vertical strip drains are the primary sampling unit.

9.2 *Laboratory Sample*—Remove the outer wrap of drain material from the roll to avoid sampling and testing any material which may have been damaged during storage. Take for the laboratory sample a 1830 mm length of the drain material.

9.3 *Test Specimens*—From the laboratory sample taken from each lot, cut test specimens as directed in Section 10. Each test specimen shall be 610 mm long.

10. Number of Specimens (Methods A and B)

10.1 Unless otherwise agreed upon, as when provided in an applicable material specification, take a number of test speci-

mens per laboratory sample such that the user may expect the 95 % probability level that the test result is no more than 5 % above the average for each laboratory sample.

10.1.1 *Reliable Estimate of v*—When there is a reliable estimate of *v* based upon extensive test records for similar materials in the user’s laboratory as directed in the method, calculate the required number of specimens using Eq 1 as follows:

$$n = (tv/A)^2 \tag{1}$$

where:

- n* = number of test specimens, rounded upward to a whole number,
- v* = reliable estimate of coefficient of variation of individual observations on similar materials in the user’s laboratory under single operator precision, %,
- t* = the value of Student’s *t* for *I* = one sided limits, at 95 % probability level, and the degrees of freedom associated with the estimate of *v*, and
- A* = 5.0 % of the average, the value of the allowable variation.

10.1.2 *No Reliable Estimate of v*—When there is no reliable estimate of *v* for the user’s laboratory, Eq 1 should not be used directly. Instead, specify the fixed number of three specimens for testing.

11. Conditioning

11.1 Prior to testing, the specimens shall be conditioned at the standard atmosphere for testing geosynthetics for 24 h prior to testing. If the environment of the user’s laboratory is unable to be maintained at the standard atmosphere for testing geosynthetics, the specimens shall be conditioned for 24 h in the environment in which they will be tested.

12. Procedure

12.1 Method A:

12.1.1 Specimen Preparation—Wrap the full length of each specimen with heat shrink plastic. Using the blow dryer, apply heat until the wrap has shrunk tightly around the specimens.

NOTE 2—The heat shrink wrap seals the geotextile so that water will not escape through it, but rather flow parallel to the plane of the drain for the full length of the specimen.

12.1.2 Place the specimen through the slot in the bottom plate of the water chamber assembly. The specimen should protrude up into the chamber 6.35 mm. Seal the specimen into the slot with easily a removable sealant, such as bathtub caulk.

12.1.2.1 Thread the specimen down through the upper and lower level specimen holders of the test stand, and fasten the bottom plate of the water chamber assembly to the stand. Complete the assembly of the water chamber assembly. Tighten the plates of the specimen holders snugly against the specimen, being careful not to pinch the specimen too tight such that the flow of water will be affected.

12.1.3 Fill the water chamber to the outlet of the chamber. Adjust the flow to maintain a constant head of 610 mm on the specimen.

NOTE 3—The head is measured from the water chamber outlet pipe to the point where the water exits the drain.

12.1.4 Take and record five flow measurements (Q in mL) over a set time interval (t) in the uncrimped condition. Generally 5 s is used as the time interval.

12.1.5 Following the fifth reading in the uncrimped condition, shut off the water flow to the water chamber, and allow the chamber to empty.

12.1.5.1 Once the water chamber is empty, loosen the lower specimen holder. Crimp the specimen by tuning the handle of the crimp device until the specimen is crimped to the 90° angle of the crimper. See Fig. 1.

NOTE 4—Extreme care needs to be taken when crimping the specimen such that it is not pinched.

12.1.6 Repeat 12.1.3 – 12.1.5 for the crimped condition.

12.1.7 Repeat 12.1.1 – 12.1.6 for the remaining specimens.

12.2 Method B:

NOTE 5—The measurement of discharge capacity of the prefabricated strip drain is carried out under two conditions, namely, straight line and bending line. Firstly, the measurement of the discharge capacity in the straight line condition should be performed after the sample is vertically mounted. In the bending line condition, the measurement should be performed while maintaining the bending state in a fixed format, using the bending state maintaining device while preparing the supplemental length in addition to the length required in the straight line condition, depending on the current bending state.

12.2.1 The test specimens are extracted from the sample exposed to a temperature of 20 ± 2 °C for 2 h by a sufficient length required for the mounting operation.

12.2.2 The sample is wrapped with rubber membrane of a thickness of less than 0.35 mm. Herein, the rubber membrane must be smoothly mounted so as to ensure no wrinkles are formed.

12.2.3 The sample equipped with the rubber membrane is digested within the water of a room temperature, including the

humectants, and is moistened for at least 12 h while slowly being stirred to remove any bubbles. The humectants include a strength of 0.1 % V/V.

12.2.4 The sample of the prefabricated strip drain is mounted on the sample mounting portion in a straight line or bending line shape so as to be in accordance with the test conditions. See Fig. 4.

12.2.5 In principle, a pressure of 300 kPa should be applied to the internal of a cylinder.

NOTE 6—Other pressure levels may be applied with the agreement of all concerned persons or parties. When pressurized, any sudden increase in pressure may cause damage to the surface of the rubber membrane. Therefore, pressure should preferably be increased by 50 kPa. In other words, a pressure of 50 kPa is firstly applied first thereto, with the pressure of the next step then applied after the water provided by the water supply passes through the mounted sample. In this regard, the procedure applying the pressure at each stage should progress in consideration of the following aspects. After the application of pressure at the first stage, the applied state should be fixated for more than 1 min, and then the pressure of the next stage is applied thereto, meaning that the pressure can be increased to the finally settled pressure in sequential order. Herein, it should be noted that the maximum time required in reaching the preset pressure should not exceed 30 min.

12.2.6 If the supplied water is provided to the flow rate measurement portion, the head difference between the water supply and the flow rate measurement portion is adjusted to be in accordance with the hydraulic gradient of 0.5 or the agreed hydraulic gradient, where agreed.

12.2.7 The variation of pressure during the desired measurement period should be less than 10 %. The water flow per unit of time is measured at the elapsing of the preset time (1) after the finally fixed pressure is applied in 7.5. Herein, the water flow should be at least 1000 cm³, and the measurement time should be at least 30 s.

NOTE 7—In principle, pressure should be measured over the periods of one week (seven days), and four weeks (28 days). The measurement time can be added with the agreement of the concerned persons or parties.

12.2.8 The temperature of the water must be recorded when the flow rate is measured in 12.2.7.

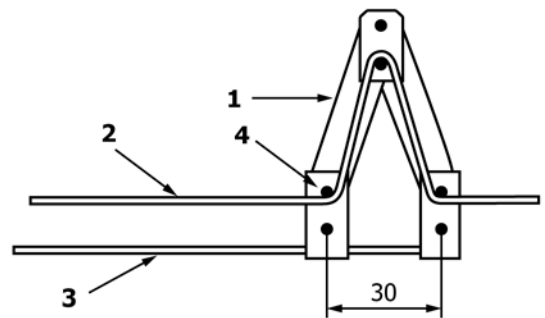

- 1. supporter
- 2. vertical strip drain
- 3. guide
- 4. fixing pin - diameter: 5.0 ± 0.5

FIG. 4 Crimp Device for Method B