



Designation: C1248 – 22

Standard Test Method for Staining of Porous Substrate by Joint Sealants¹

This standard is issued under the fixed designation C1248; the number immediately following the designation indicates the year of original adoption or, in the case of revision, the year of last revision. A number in parentheses indicates the year of last reapproval. A superscript epsilon (ϵ) indicates an editorial change since the last revision or reapproval.

1. Scope

1.1 This test method covers four types of laboratory tests to determine if a joint sealant has a probability of staining a porous substrate (such as marble, limestone, sandstone, granite, or other similar material). The tests are on compressed samples and include (1) storage under standard laboratory conditions, (2) storage in an oven, and (3) exposure in a fluorescent UV/condensation device, and (4) exposure in a xenon arc device.

1.2 The values stated in SI units are to be regarded as standard. The values given in parentheses after SI units are provided for information only and are not considered standard.

1.3 *This standard does not purport to address all of the safety concerns, if any, associated with its use. It is the responsibility of the user of this standard to establish appropriate safety, health, and environmental practices and determine the applicability of regulatory limitations prior to use.*

1.4 This standard is similar, but not identical, to ISO 16938-1.

1.5 *This international standard was developed in accordance with internationally recognized principles on standardization established in the Decision on Principles for the Development of International Standards, Guides and Recommendations issued by the World Trade Organization Technical Barriers to Trade (TBT) Committee.*

2. Referenced Documents

2.1 *ASTM Standards:*²

- C717 Terminology of Building Seals and Sealants
- C920 Specification for Elastomeric Joint Sealants
- C1442 Practice for Conducting Tests on Sealants Using Artificial Weathering Apparatus
- G113 Terminology Relating to Natural and Artificial Weathering Tests of Nonmetallic Materials

¹ This test method is under the jurisdiction of ASTM Committee C24 on Building Seals and Sealants and is the direct responsibility of Subcommittee C24.40 on Weathering.

Current edition approved July 1, 2022. Published August 2022. Originally approved in 1993. Last previous edition approved in 2018 as C1248-18. DOI: 10.1520/C1248-22.

² For referenced ASTM standards, visit the ASTM website, www.astm.org, or contact ASTM Customer Service at service@astm.org. For *Annual Book of ASTM Standards* volume information, refer to the standard's Document Summary page on the ASTM website.

ering Tests of Nonmetallic Materials

G151 Practice for Exposing Nonmetallic Materials in Accelerated Test Devices that Use Laboratory Light Sources

G154 Practice for Operating Fluorescent Ultraviolet (UV) Lamp Apparatus for Exposure of Nonmetallic Materials

G155 Practice for Operating Xenon Arc Lamp Apparatus for Exposure of Materials

2.2 *ISO Standard:*³

ISO 16938-1 Buildings and civil engineering works — Determination of the staining of porous substrates by sealants used in joints — Part 1: Test with compression

3. Terminology

3.1 *Definitions:*

3.1.1 Refer to Terminology C717 and G113 for definitions of terms used in this test method.

4. Summary of Test Method

4.1 In this test method standard joint specimens are compressed and clamped at the manufacturer's rated movement capability and subjected to the following treatments; (a) four of the specimens are stored at standard conditions while under compression for up to 28 days; (b) four of the specimens are exposed in an oven while under compression for up to 28 days; (c) four of the specimens are exposed either in a fluorescent UV/condensation device or in a xenon arc device while under compression for up to 28 days.

4.1.1 This test method allows for additional exposure beyond the minimum 28 day exposure period as described in 4.1. If it is desired to extend the exposure period beyond 28 days, prepare an additional six specimens for each extended exposure period. Of these six specimens prepared, two specimens each should be stored as described in the three conditions named in 4.1.

4.2 The effects of the test are evaluated by visual inspection for changes in surface appearance and average measurements of any stain depth and stain width.

4.3 This test method is applicable to any type of elastomeric joint sealant and any type of porous substrate.

³ Available from International Organization for Standardization (ISO), ISO Central Secretariat, Chemin de Blandonnet 8, CP 401, 1214 Vernier, Geneva, Switzerland, <https://www.iso.org>.

5. Significance and Use

5.1 Staining of building materials is an aesthetically undesirable occurrence. This test method evaluates the likelihood of a sealant causing an early stain on a porous substrate due to exudation of materials from the sealant. Since this is an accelerated test, it does not necessarily predict that the tested sealants will not stain or discolor porous substrates over longer periods of time.

6. Apparatus

6.1 *Forced-Draft Oven.*

6.2 *Exposure Apparatus:*

6.2.1 Fluorescent UV/condensation apparatus that conforms to the requirements in Practices G151 and G154 with UVA-340 type lamps.

6.2.2 Xenon-Arc apparatus that conforms to the requirements in Practices G151 and G155 with daylight type filters.

6.3 *Casting Spacers.*

6.4 *Masking Tape.*

7. Test Specimens

7.1 Substrates shall be 25 mm by 25 mm by 75 mm (0.98 in. by 0.98 in. by 2.95 in.). A total of 24 substrate pieces are required to make the twelve test specimens.

7.1.1 If testing beyond the minimum 28 day exposure period, prepare an additional twelve substrates to make the six additional test specimens as required in 4.1.1.

NOTE 1—The precision and bias statement is based on Vermont white marble and Bethel white granite substrates.

7.2 *Primers*—When a primer is recommended by the sealant manufacturer, apply the primer to one substrate block of each test specimen. Apply the primer where the sealant will be in contact with the substrate.

7.3 *Preparation of Test Specimens:*

7.3.1 *Multi-Component Sealants*—Prepare twelve test specimens for each substrate that is to be used in the test. After maintaining the unopened sample for at least 24 h at standard conditions, mix thoroughly at least 250 g of base compound with the appropriate amount of curing agent. Apply a bead of sealant 13 mm by 13 mm by 50 mm (0.51 in. by 0.51 in. by 1.97 in.) between parallel 25 mm by 75 mm (0.98 in. by 2.95 in.) faces of substrates (see Fig. 1). Use appropriate casting spacers to form the proper size bead. Use adhesive tape, rubber bands, or clamps to hold the test specimen together before and after filling it with the sealant. In the case of a self-leveling sealant, use masking or other suitable tape to retain the sealant. Use masking tape on the top surface of substrates to prevent sealant from being over-applied onto the top surface. Remove the tape immediately following filling of the specimen joint cavity.

7.3.2 *Single-Component Sealants*—Prepare the specimens as described in 7.3.1 except that no mixing is required. Condition the sealed cartridge or bulk container at standard conditions for at least 24 h before use.

8. Conditioning

8.1 Cure specimens for 21 days at standard conditions. Separate the casting spacers from the sealant as soon as practical during the curing period without damaging the sealant. If the sealant is damaged, re-assemble fresh specimens and repeat, allowing for a longer curing duration prior to re-attempting casting spacer removal. Sealant should not become damaged upon removal of casting spacers.

NOTE 2—The producer may request conditions other than standard conditions for the curing of single-component sealants provided they meet the following requirements: the curing period shall extend for 21 days; and the temperature during the curing period shall not exceed 50 °C (122 °F).

9. Procedure

9.1 Compress all test specimens and clamp them at the manufacturer's rated movement class in accordance with Specification C920 for the sealant being tested.

9.2 Store four compressed specimens at standard conditions. Remove two after 14 days and two after 28 days.

9.2.1 If testing beyond the minimum 28 day exposure period, prepare an additional two compressed specimens at standard conditions for each extended period, and remove those two compressed specimens at the end of each extended period.

9.3 Place four compressed specimens in an oven at 70 °C ± 2 °C (158 °F ± 3.6 °F). Remove two after 14 days and two after 28 days.

9.3.1 If testing beyond the minimum 28 day exposure period, place an additional two compressed specimens in an oven at 70 ± 2 °C (158 ± 3.6 °F) for each extended period, and remove those two compressed specimens at the end of each extended period.

9.4 Expose four compressed samples in one of the laboratory accelerated exposure devices listed below. Choice of type of apparatus shall be by mutual agreement among the interested parties. Because of differences in type of light source and test conditions, test results may differ with the type of apparatus used. Consult Practices G154 and G155 for differences in the spectral power distributions of the exposure sources and Practice C1442 for differences in test parameters in the two types of apparatus specified.

9.4.1 If testing beyond the minimum 28 day exposure period, similarly expose two additional compressed samples in the devices as described in 9.4, for each extended period.

9.4.2 *Procedure for Fluorescent UV/Condensation Apparatus*—Operate the device in accordance with the procedure in Section 7.3 of Practice C1442. Remove two specimens after 14 days (336 h) and two after 28 days (672 h).

9.4.2.1 If testing beyond the minimum 28 day exposure period, similarly remove the two additional test specimens from the weathering device, after each extended period has elapsed.

9.4.3 *Procedure for Xenon-Arc Apparatus*—Operate the device in accordance with the procedure in Section 7.2 of Practice C1442. When operated at the preferred irradiance level of 0.51 W/(m² · nm) at 340 nm, remove two specimens after 14 days (617 kJ/(m² · nm) at 340 nm) and two specimens

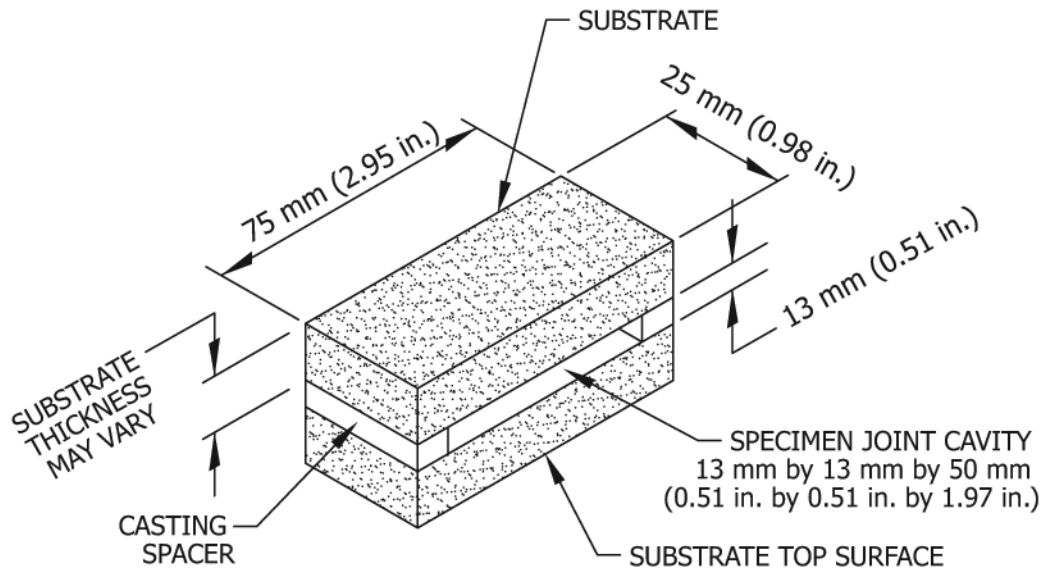

(A) PREPARED SPECIMEN BEFORE APPLICATION OF SEALANT

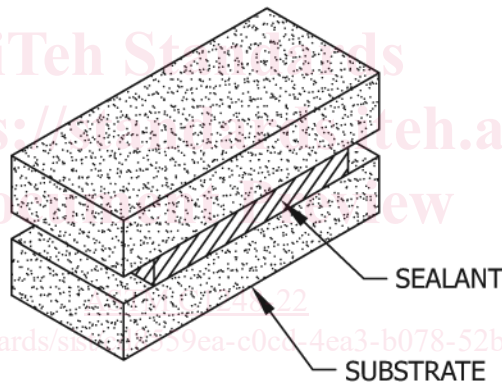

(B) SPECIMEN AFTER APPLICATION OF SEALANT & REMOVAL OF SPACER

FIG. 1 Stain Test Specimen

after 28 days ($1234 \text{ kJ}/(\text{m}^2 \cdot \text{nm})$ at 340 nm). See Annex A1 in C1442 for determining the exposure time required to provide the same radiant exposure at other irradiance levels.

9.4.3.1 If testing beyond the minimum 28 day exposure period, similarly remove the two additional test specimens after each extended period has elapsed, from the Xenon-Arc Apparatus. When operated at the preferred irradiance level of $0.51 \text{ W}/(\text{m}^2 \cdot \text{nm})$ at 340 nm, the exposure is $44.07 \text{ kJ}/(\text{m}^2 \cdot \text{nm})$ at 340 nm, per day of exposure.

9.5 Allow specimens to cool at standard conditions for one day. Examine the surface of the substrates (both pieces on each specimen) to determine if the surface appearance has changed in any way. Measure the width of any stain in at least three places. Record the average of the measurements to the nearest

0.5 mm. If primer was used, record the stain width separately for the primed and unprimed substrates on each specimen.

9.6 Break the substrates into two pieces along the 25 mm axis (the final pieces will be approximately 40 mm by 25 mm by 25 mm in size). If there was a surface stain, break the substrates at the point of maximum surface stain. Measure the stain depth in at least three places. Record the average of the measurements to the nearest 0.5 mm.

10. Report

10.1 Report the following information:

10.1.1 Name of sealant, type of sealant, rated movement class, and identifying batch number,

10.1.2 Substrates used,