



Designation: ~~F1045 – 16<sup>ε1</sup>~~ F1045 – 22

An American National Standard

## Standard Performance Specification for Ice Hockey Helmets<sup>1</sup>

This standard is issued under the fixed designation F1045; the number immediately following the designation indicates the year of original adoption or, in the case of revision, the year of last revision. A number in parentheses indicates the year of last reapproval. A superscript epsilon ( $\epsilon$ ) indicates an editorial change since the last revision or reapproval.

---

<sup>ε1</sup> NOTE—Editorially corrected 11.1.1 in February 2022.

---

### INTRODUCTION

Ice hockey is a contact sport with intrinsic hazards. The use of protective equipment will not eliminate all injuries but should substantially reduce the severity and frequency of injury. Participation in the sport of ice hockey by a player implies acceptance of some risk of injury. The goal is to minimize this risk.

This performance specification for head protective equipment has been prepared after consideration of head protection relative to the following principle risks: high-mass, low-velocity impact (various playing situations), and fit. This performance specification may be modified as other risks are identified.

Performance requirements were determined after consideration of state-of-the-art of helmet design and manufacture and the demands of the sport.

### 1. Scope

1.1 This performance specification<sup>2</sup> covers performance requirements for ice hockey helmets.

1.2 The intent of this performance specification is to reduce the risk of injury to the head without compromising the form and appeal of the game.

1.3 This performance specification covers: (1) performance tests for shock absorption properties of the complete helmet and strength and elongation of the chin strap and its attachment; and (2) requirements for area of coverage and penetration.

1.4 The values stated in SI units are to be regarded as standard. The values given in parentheses are for information only.

1.5 The following precautionary caveat pertains only to the test methods portion, Section 12, of this performance specification: *This standard does not purport to address all of the safety concerns, if any, associated with its use. It is the responsibility of the user of this standard to establish appropriate safety, health, and environmental practices and determine the applicability of regulatory limitations prior to use.*

1.6 *This international standard was developed in accordance with internationally recognized principles on standardization established in the Decision on Principles for the Development of International Standards, Guides and Recommendations issued by the World Trade Organization Technical Barriers to Trade (TBT) Committee.*

---

<sup>1</sup> This performance specification is under the jurisdiction of ASTM Committee F08 on Sports Equipment, Playing Surfaces, and Facilities and is the direct responsibility of Subcommittee F08.15 on Ice Hockey.

Current edition approved Oct. 1, 2016; June 15, 2022. Published November 2016; August 2022. Originally approved in 1988. Last previous edition approved in 2015 as F1045 – 15; F1045 – 16<sup>ε1</sup>. DOI: 10.1520/F1045-16E01-10.1520/F1045-22.

<sup>2</sup> This performance specification is subject to revision as indicated by subsequent injury statistics and subject to review at least every five years.

## 2. Referenced Documents

### 2.1 ASTM Standards:<sup>3</sup>

**F513 Specification for Eye and Face Protective Equipment for Hockey Players**

### 2.2 CEN Standard:<sup>4</sup>

**EN 960:2006 Headforms for use in the testing of protective helmets**

## 3. Terminology

### 3.1 Definitions of Terms Specific to This Standard:

#### 3.1.1 retention system:

3.1.1.1 *chin strap*—the chin strap, including a cup that covers the chin (see Fig. 1), is affixed to both sides of the helmet and secures the helmet to the head when a Type I or Type II full face protector is not worn with the helmet.

3.1.1.2 *neck strap*—the neck strap that secures the helmet to the head is affixed on both sides of the helmet and passes under the lower jaw in close proximity to the jaw and the neck. Where the helmet is worn with a Type I or Type II full face protector, the neck strap serves as the attachment of the helmet to the head.

NOTE 1—For a description of the Type I or Type II face protector, see the Types of Protectors Section in Safety Specification F513.

3.1.2 *crown*—a point in the median plane that is equal chord lengths from the anterior and posterior intersections of the median and reference planes.

3.1.3 *drop height*—the vertical distance between the lowest point (impact point) of the elevated helmet and the apex of the impact surface.

3.1.4 *g*—the dimensionless ratio of the acceleration of the headform during impact to the acceleration due to gravity.

3.1.4.1  $g_{\max}$ —the maximum value of *g* encountered during impact.

3.1.5 *helmet*—the complete product, including the shell, liner, chin strap, including the cup or neck strap, and associated attachment hardware, assembled with components supplied by the manufacturer. The helmet is intended to protect the wearer's head while participating in ice hockey.

3.1.6 *helmet position index (HPI)*—the vertical distance from the brow of the helmet to the basic plane, when the helmet is placed on a reference headform. The manufacturer shall specify the size of the headform and the vertical distance.

3.1.7 *liner*—the material inside the shell for the purpose of shock absorption or comfortable fit, or both.

#### 3.1.8 Reference Planes:

3.1.8.1 *basic plane*—an anatomical plane that includes the superior rim of the external auditory meatus (upper edge of the external openings of the ear) and the inferior margin of the orbit (the lowest point of the floor of the eye socket). The headforms are marked with the basic plane (see Figs. 2 and 3).

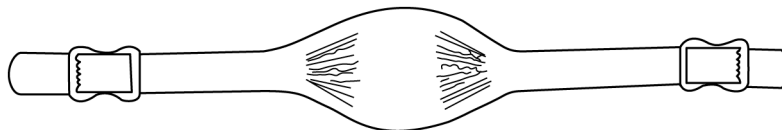

**FIG. 1 Chin Strap (Includes a Chin Cup)**

<sup>3</sup> For referenced ASTM standards, visit the ASTM website, [www.astm.org](http://www.astm.org), or contact ASTM Customer Service at [service@astm.org](mailto:service@astm.org). For *Annual Book of ASTM Standards* volume information, refer to the standard's Document Summary page on the ASTM website.

<sup>4</sup> Available from European Committee for Standardization (CEN), Avenue Marnix 17, B-1000, Brussels, Belgium, <http://www.cen.eu>.

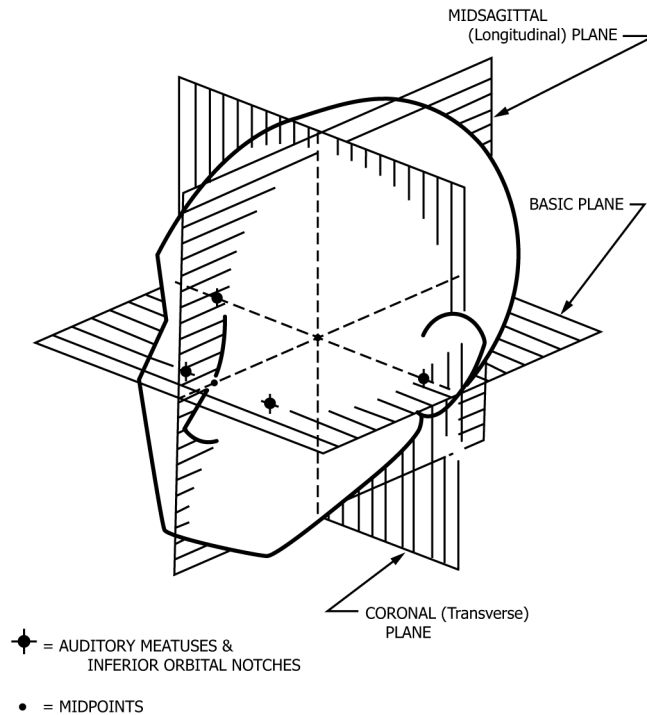

FIG. 2 Anatomical Planes

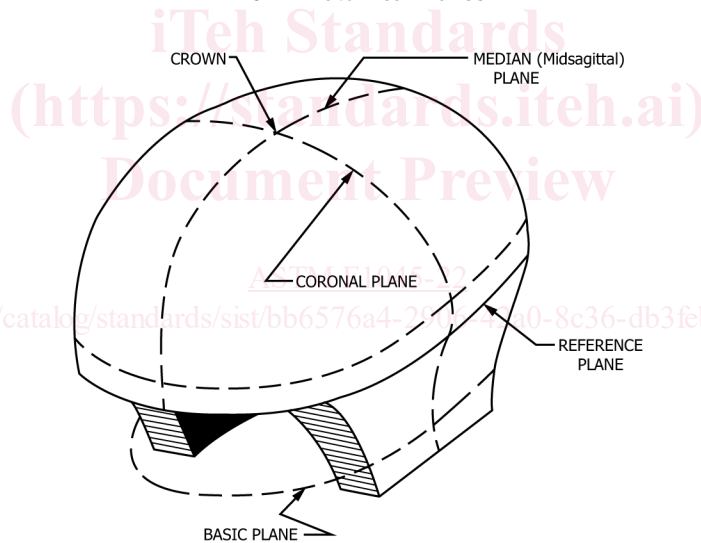

FIG. 3 Test Headform—Basic, Reference, and Midsagittal Planes

3.1.8.2 *coronal plane*—an anatomical plane perpendicular to both the basic and midsagittal planes and passing through the superior rims of the right and left auditory meatuses. The transverse plane corresponds to the coronal plane (see Figs. 2 and 3).

3.1.8.3 *midsagittal plane*—an anatomical plane perpendicular to the basic plane and containing the midpoint of the line connecting the notches of the right and left inferior orbital ridges and the midpoint of the line connecting the superior rims of the right and left external auditory meatus. The longitudinal plane corresponds to the midsagittal plane (see Figs. 2 and 3).

3.1.8.4 *reference plane*—a plane marked on the headforms at a specified distance above and parallel to the basic plane (see Fig. 4).

3.1.9 *shell*—the rigid outer material that gives the helmet its form.

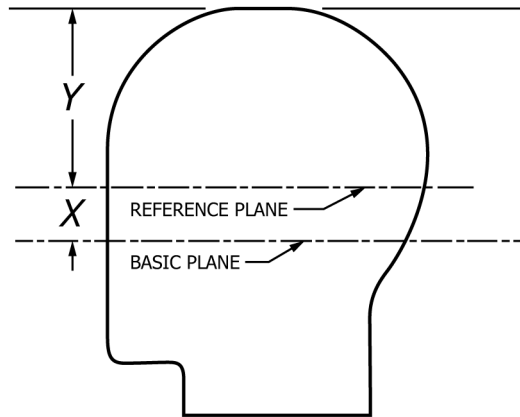

Headform circumference (mm)	X, mm	Y, mm
495	23.5	89.7
535	25.5	96
575	27.5	102.4
605	29	107.2

FIG. 4 Location of Reference Lines

#### 4. General Requirements

##### 4.1 Materials:

4.1.1 All materials used in the fabrication of helmets shall be known to be suitable for the intended application. For example, shell materials shall remain strong, semirigid, and firm, and shall not permanently distort during an exposure of at least 4 h to any temperature in the range from  $-27$  to  $32^{\circ}\text{C}$ , nor shall the material be significantly affected by exposure to ultraviolet radiation, water, dirt, or vibration. All materials shall be rot-resistant. In addition, paints, glues, and finishes used in manufacture shall be compatible with the helmet shell and shock absorption system materials.

<https://standards.iteh.ai/catalog/standards/sist/bb6576a4-2906-42a0-8c36-db3febba85cc/astm-f1045-22>

4.1.2 Materials coming into contact with the wearer’s head shall not be the type known to cause skin irritation or disease, and shall not undergo significant loss of strength, flexibility, or other physical change as a result of contact with perspiration, oil, or grease from the wearer’s hair.

4.1.3 Any material used in the construction of helmets shall not be adversely affected by ordinary household soap and water, mild household detergent, or cleaners recommended by the manufacturer.

##### 4.2 Helmet Assembly:

4.2.1 Any optional devices fitted to the helmet shall be so designed that they are unlikely to cause any injury to the wearer or other participants during contact.

4.2.2 All edges shall be smooth and rounded and there shall be no rigid projections on the inside of the helmet that could come in contact with the wearer’s head.

4.2.3 All external projections shall be smooth and adequately faired to other surfaces. Split or bifurcated rivets shall not be used.

##### 4.3 Types of Protectors:

4.3.1 *Type 1*—Head protectors that meet requirements for the area of coverage mentioned in 4.5.1.

4.3.2 *Type 2*—Head protectors that meet requirements for the area of coverage mentioned in 4.5.2.

4.4 *Impact Test Protected Area*—The area above the test line (see 12.2.7) shall be considered the impact test protected area. All parts of the wearer’s head covered by the area of the shell shall be protected at least to the minimum impact requirements of 13.1 and 13.2.

4.5 *Area of Coverage*—Area of coverage measurements shall be made with the protector mounted in accordance with the protector manufacturer’s instructions on the headforms that correspond to the physical dimensions defined in EN 960:2006 as headform circumferences 495, 535, 575, or 605 mm. If a helmet size range, as identified by the manufacturer’s instructions, is capable of fitting two different headforms, the larger headform shall be used.

4.5.1 *Type 1*—The extent of coverage shall include at least all of the area above line BCDEF as shown in Fig. 5. This area shall correspond with the headform size with which the protector is to be tested. No ear aperture shall have any dimension exceeding 38 mm (1.5 in.). The ear aperture shall be completely surrounded by the helmet. The distance from any edge of an ear aperture to any edge of the helmet shall not be less than 20 mm (0.8 in.).

4.5.2 *Type 2*—The extent of coverage shall include at least all of the area above line BCDGHEF as shown in Fig. 6. This area shall correspond with the headform size with which the protector is to be tested.

4.6 *Attachments*—The components of the fasteners for securing attachments to the shell shall be so attached that the degree of protection afforded the wearer by the protective padding or cushioning material of the helmet is not thereby reduced.

4.7 *Size of Helmets*—Helmets shall be sized in accordance with Table 1.<sup>5</sup>

4.8 *Chin Strap or Neck Strap:*

4.8.1 The chin strap, including the cup, or the neck strap, shall be attached to the helmet so that the helmet remains in its normal position on the player’s head during play and impact conditions.

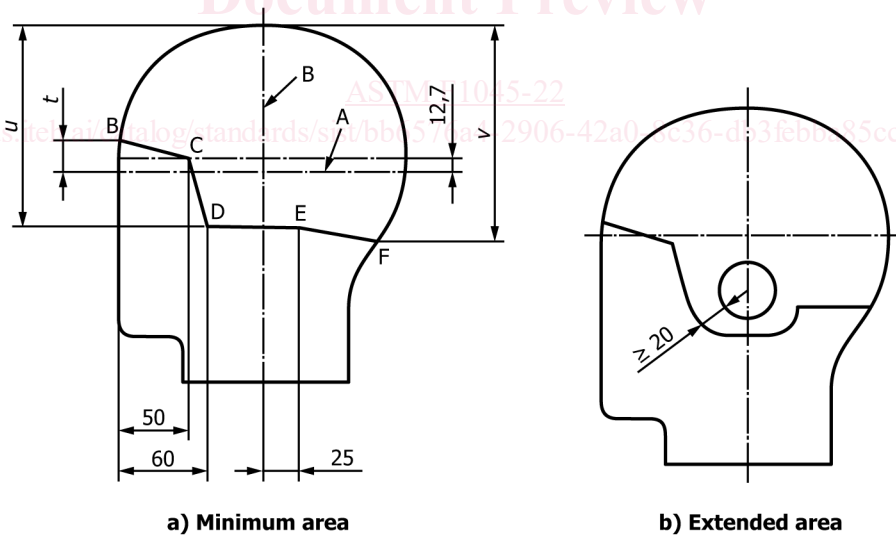

Headform circumference (mm)	Distance (mm)		
	t	u	v
495	24	123	132
535	26	128	140
575	27	129.9	144.9
605	28	132.2	151.2

NOTE 1—A—Reference plane, B—Coronal plane

FIG. 5 Type 1—Area of Coverage

<sup>5</sup> Table should be used for information only.

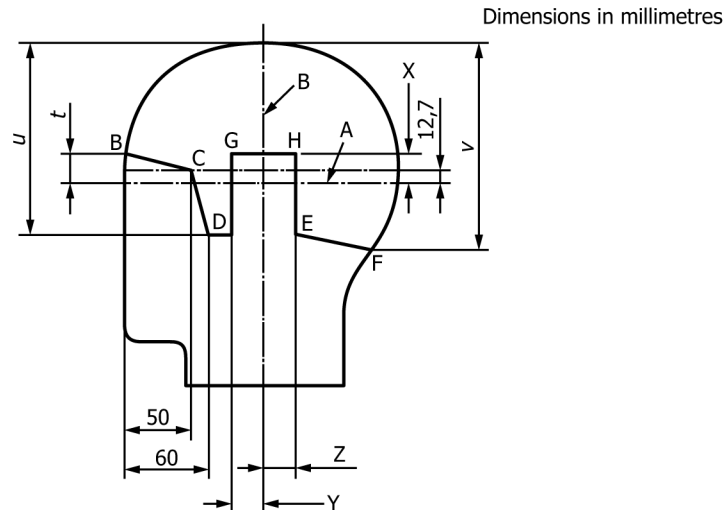

c) Minimum area

Headform circumference (mm)	Distance (mm)					
	t	u	v	x	y	z
495	24	123	132	—	—	—
535	26	128	140	18	30	50
575	27	129.9	144.9	20	40	55
605	28	132.2	151.2	20	45	55

NOTE 1—A-Reference plane, B-Coronal plane

NOTE 2—Dimension Y and Z are taken and must cover between the reference and the basic plane.

NOTE 3—495 mm Headform does not have Type 2 coverage.

FIG. 6 Type 2—Area of Coverage

TABLE 1 Hat Sizes and Head Fittings

NOTE 1—These are U.S. and Canadian hat sizes.

Hat Size	Circumference of Head	
	in.	mm
6	19	483
6 <sup>1</sup> / <sub>8</sub>	19 <sup>3</sup> / <sub>8</sub>	492
6 <sup>1</sup> / <sub>4</sub>	19 <sup>1</sup> / <sub>2</sub>	502
6 <sup>3</sup> / <sub>8</sub>	20 <sup>1</sup> / <sub>8</sub>	511
6 <sup>1</sup> / <sub>2</sub>	20 <sup>1</sup> / <sub>2</sub>	521
6 <sup>5</sup> / <sub>8</sub>	20 <sup>7</sup> / <sub>8</sub>	530
6 <sup>3</sup> / <sub>4</sub>	21 <sup>1</sup> / <sub>4</sub>	540
6 <sup>7</sup> / <sub>8</sub>	21 <sup>5</sup> / <sub>8</sub>	550
7	22	559
7 <sup>1</sup> / <sub>8</sub>	22 <sup>3</sup> / <sub>8</sub>	568
7 <sup>1</sup> / <sub>4</sub>	22 <sup>3</sup> / <sub>4</sub>	578
7 <sup>3</sup> / <sub>8</sub>	23 <sup>1</sup> / <sub>8</sub>	587
7 <sup>1</sup> / <sub>2</sub>	23 <sup>1</sup> / <sub>2</sub>	597
7 <sup>5</sup> / <sub>8</sub>	23 <sup>7</sup> / <sub>8</sub>	606
7 <sup>3</sup> / <sub>4</sub>	24 <sup>1</sup> / <sub>4</sub>	616
7 <sup>7</sup> / <sub>8</sub>	24 <sup>5</sup> / <sub>8</sub>	625
8	25	635

4.8.2 The chin strap or the neck strap used in combination with the face protector shall satisfy the requirements in 3.1.1.

4.8.3 The minimum width of the chin strap exclusive of the cup shall be 12.7 mm (0.5 in.)-13 mm.

## 5. Performance Requirements

5.1 *General*—Helmets shall be capable of meeting the requirements in this performance specification throughout their full range of adjustment. They shall be capable of meeting the requirements in Sections 11 and 12 at any temperature between -27 to 32°C.

5.2 *Shock Absorption*—The helmet is mounted on a headform that is oriented in different positions and dropped at a specific velocity onto an impact surface. A linear accelerometer mounted at the center of gravity of the headform monitors the acceleration and the time history of impact that are recorded with appropriate instrumentation. Maximum acceleration and time duration data obtained by the specified procedures are intended to determine the shock absorption characteristics of the helmet.

5.3 *Chin Strap*—When tested in accordance with [12.812.7.2.1](#), the force to separate the strap shall not be less than 50 N (11.2 lbf) nor more than 500 N (112.4 lbf), and the maximum displacement of the strap shall not exceed 25.4 mm (1 in.) at a load of 109 N (24.5 lbf). The requirements of [12.812.7.2.1](#) shall be met at ambient conditions.

5.4 *Penetration Resistance Test Requirements*—It shall not be possible to touch the test headform with the curved end of the test stick blade within the required area of coverage, excluding the ear opening.

## 6. Apparatus

6.1 *Shock Absorption Test*—The apparatus for the shock absorption test shall consist of the following:

6.1.1 *Guide Assembly*—The headform shall be attached to the free fall drop assembly carriage by an adjustable mounting that will allow impacts to be delivered to any prescribed point on the helmet (see [Fig. 7](#)). The carriage shall be free to slide on vertical guides. If wires are used, they must be placed under at least 845.2 N (190 lbf) tension (see [12.4](#) for guide assembly specifications and allowable weight of drop assembly).

6.1.2 *Recording Equipment*—The recording equipment shall meet the following criteria:

6.1.2.1 *Acceleration Transducer*—The linear accelerometer is mounted at the center of gravity of the combined test headform and carriage assembly with the sensitive axis aligned to within 5° of the vertical when the helmet and headform are in the impact

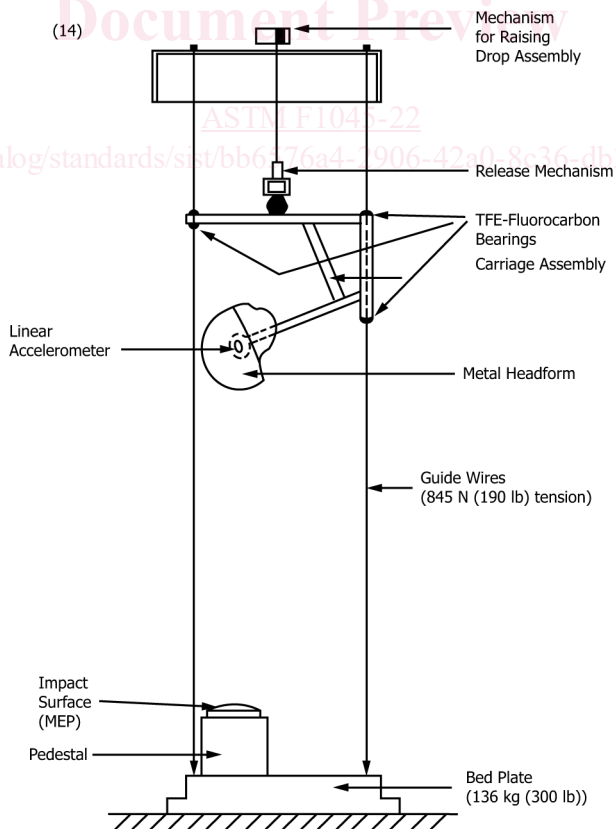

NOTE 1—Rail-guided drop assemblies are also permissible.

**FIG. 7 Schematic of Typical Drop Assembly**