



Standard Performance Specification for Ice Hockey Helmets¹

This standard is issued under the fixed designation F1045; the number immediately following the designation indicates the year of original adoption or, in the case of revision, the year of last revision. A number in parentheses indicates the year of last reapproval. A superscript epsilon (ϵ) indicates an editorial change since the last revision or reapproval.

INTRODUCTION

Ice hockey is a contact sport with intrinsic hazards. The use of protective equipment will not eliminate all injuries but should substantially reduce the severity and frequency of injury. Participation in the sport of ice hockey by a player implies acceptance of some risk of injury. The goal is to minimize this risk.

This performance specification for head protective equipment has been prepared after consideration of head protection relative to the following principle risks: high-mass, low-velocity impact (various playing situations), and fit. This performance specification may be modified as other risks are identified.

Performance requirements were determined after consideration of state-of-the-art of helmet design and manufacture and the demands of the sport.

1. Scope

1.1 This performance specification² covers performance requirements for ice hockey helmets.

1.2 The intent of this performance specification is to reduce the risk of injury to the head without compromising the form and appeal of the game.

1.3 This performance specification covers: (1) performance tests for shock absorption properties of the complete helmet and strength and elongation of the chin strap and its attachment; and (2) requirements for area of coverage and penetration.

1.4 The values stated in SI units are to be regarded as standard. The values given in parentheses are for information only.

1.5 The following precautionary caveat pertains only to the test methods portion, Section 12, of this performance specification: *This standard does not purport to address all of the safety concerns, if any, associated with its use. It is the responsibility of the user of this standard to establish appropriate safety, health, and environmental practices and determine the applicability of regulatory limitations prior to use.*

¹ This performance specification is under the jurisdiction of ASTM Committee F08 on Sports Equipment, Playing Surfaces, and Facilities and is the direct responsibility of Subcommittee F08.15 on Ice Hockey.

Current edition approved June 15, 2022. Published August 2022. Originally approved in 1988. Last previous edition approved in 2016 as F1045 – 16^{ε1}. DOI: 10.1520/F1045-22.

² This performance specification is subject to revision as indicated by subsequent injury statistics and subject to review at least every five years.

1.6 *This international standard was developed in accordance with internationally recognized principles on standardization established in the Decision on Principles for the Development of International Standards, Guides and Recommendations issued by the World Trade Organization Technical Barriers to Trade (TBT) Committee.*

2. Referenced Documents

2.1 *ASTM Standards:*³

F513 Specification for Eye and Face Protective Equipment for Hockey Players

2.2 *CEN Standard:*⁴

EN 960:2006 Headforms for use in the testing of protective helmets

3. Terminology

3.1 *Definitions of Terms Specific to This Standard:*

3.1.1 *retention system:*

3.1.1.1 *chin strap*—the chin strap, including a cup that covers the chin (see Fig. 1), is affixed to both sides of the helmet and secures the helmet to the head when a Type I or Type II full face protector is not worn with the helmet.

3.1.1.2 *neck strap*—the neck strap that secures the helmet to the head is affixed on both sides of the helmet and passes under the lower jaw in close proximity to the jaw and the neck.

³ For referenced ASTM standards, visit the ASTM website, www.astm.org, or contact ASTM Customer Service at service@astm.org. For *Annual Book of ASTM Standards* volume information, refer to the standard's Document Summary page on the ASTM website.

⁴ Available from European Committee for Standardization (CEN), Avenue Marnix 17, B-1000, Brussels, Belgium, <http://www.cen.eu>.

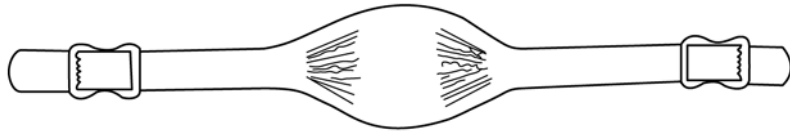

FIG. 1 Chin Strap (Includes a Chin Cup)

Where the helmet is worn with a Type I or Type II full face protector, the neck strap serves as the attachment of the helmet to the head.

NOTE 1—For a description of the Type I or Type II face protector, see the Types of Protectors Section in Safety Specification F513.

3.1.2 *crown*—a point in the median plane that is equal chord lengths from the anterior and posterior intersections of the median and reference planes.

3.1.3 *drop height*—the vertical distance between the lowest point (impact point) of the elevated helmet and the apex of the impact surface.

3.1.4 *g*—the dimensionless ratio of the acceleration of the headform during impact to the acceleration due to gravity.

3.1.4.1 g_{max} —the maximum value of *g* encountered during impact.

3.1.5 *helmet*—the complete product, including the shell, liner, chin strap, including the cup or neck strap, and associated attachment hardware, assembled with components supplied by the manufacturer. The helmet is intended to protect the wearer’s head while participating in ice hockey.

3.1.6 *helmet position index (HPI)*—the vertical distance from the brow of the helmet to the basic plane, when the helmet is placed on a reference headform. The manufacturer shall specify the size of the headform and the vertical distance.

3.1.7 *liner*—the material inside the shell for the purpose of shock absorption or comfortable fit, or both.

3.1.8 *Reference Planes:*

3.1.8.1 *basic plane*—an anatomical plane that includes the superior rim of the external auditory meatus (upper edge of the external openings of the ear) and the inferior margin of the orbit (the lowest point of the floor of the eye socket). The headforms are marked with the basic plane (see Figs. 2 and 3).

3.1.8.2 *coronal plane*—an anatomical plane perpendicular to both the basic and midsagittal planes and passing through the superior rims of the right and left auditory meatuses. The transverse plane corresponds to the coronal plane (see Figs. 2 and 3).

3.1.8.3 *midsagittal plane*—an anatomical plane perpendicular to the basic plane and containing the midpoint of the line connecting the notches of the right and left inferior orbital ridges and the midpoint of the line connecting the superior rims of the right and left external auditory meatus. The longitudinal plane corresponds to the midsagittal plane (see Figs. 2 and 3).

3.1.8.4 *reference plane*—a plane marked on the headforms at a specified distance above and parallel to the basic plane (see Fig. 4).

3.1.9 *shell*—the rigid outer material that gives the helmet its form.

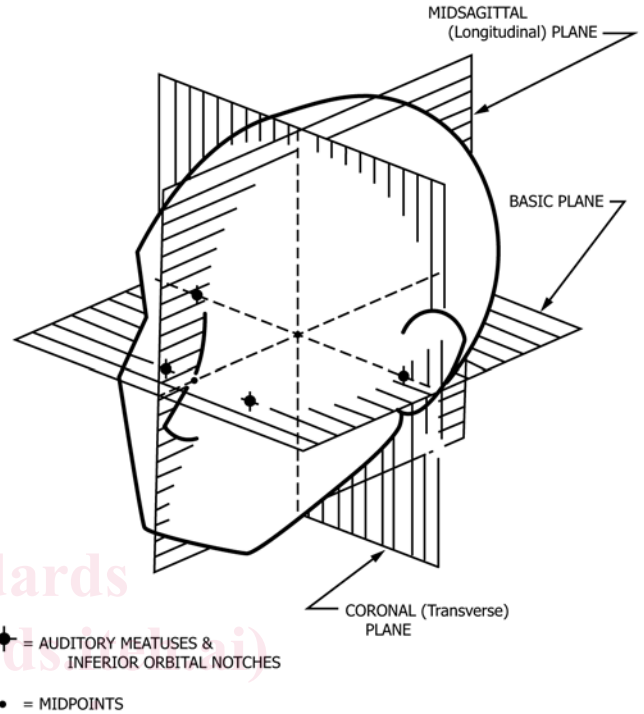

FIG. 2 Anatomical Planes

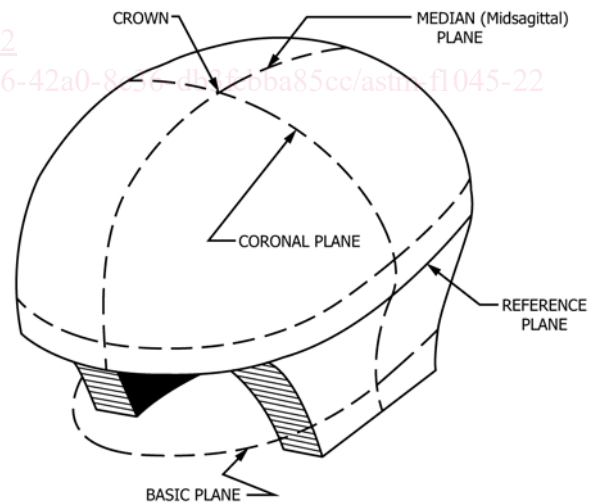

FIG. 3 Test Headform—Basic, Reference, and Misadgittal Planes

4. General Requirements

4.1 *Materials:*

4.1.1 All materials used in the fabrication of helmets shall be known to be suitable for the intended application. For example, shell materials shall remain strong, semirigid, and firm, and shall not permanently distort during an exposure of at least 4 h to any temperature in the range from -27 to 32°C, nor

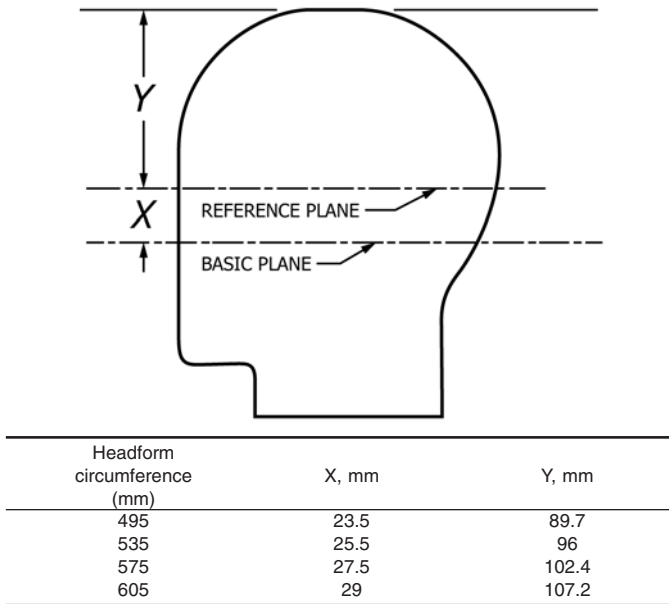

FIG. 4 Location of Reference Lines

shall the material be significantly affected by exposure to ultraviolet radiation, water, dirt, or vibration. All materials shall be rot-resistant. In addition, paints, glues, and finishes used in manufacture shall be compatible with the helmet shell and shock absorption system materials.

4.1.2 Materials coming into contact with the wearer’s head shall not be the type known to cause skin irritation or disease, and shall not undergo significant loss of strength, flexibility, or other physical change as a result of contact with perspiration, oil, or grease from the wearer’s hair.

4.1.3 Any material used in the construction of helmets shall not be adversely affected by ordinary household soap and water, mild household detergent, or cleaners recommended by the manufacturer.

4.2 *Helmet Assembly:*

4.2.1 Any optional devices fitted to the helmet shall be so designed that they are unlikely to cause any injury to the wearer or other participants during contact.

4.2.2 All edges shall be smooth and rounded and there shall be no rigid projections on the inside of the helmet that could come in contact with the wearer’s head.

4.2.3 All external projections shall be smooth and adequately faired to other surfaces. Split or bifurcated rivets shall not be used.

4.3 *Types of Protectors:*

4.3.1 *Type 1*—Head protectors that meet requirements for the area of coverage mentioned in 4.5.1.

4.3.2 *Type 2*—Head protectors that meet requirements for the area of coverage mentioned in 4.5.2.

4.4 *Impact Test Protected Area*—The area above the test line (see 12.2.7) shall be considered the impact test protected area. All parts of the wearer’s head covered by the area of the shell shall be protected at least to the minimum impact requirements of 13.1 and 13.2.

4.5 *Area of Coverage*—Area of coverage measurements shall be made with the protector mounted in accordance with the protector manufacturer’s instructions on the headforms that correspond to the physical dimensions defined in EN 960:2006 as headform circumferences 495, 535, 575, or 605 mm. If a helmet size range, as identified by the manufacturer’s instructions, is capable of fitting two different headforms, the larger headform shall be used.

4.5.1 *Type 1*—The extent of coverage shall include at least all of the area above line BCDEF as shown in Fig. 5. This area shall correspond with the headform size with which the protector is to be tested. No ear aperture shall have any dimension exceeding 38 mm (1.5 in.). The ear aperture shall be completely surrounded by the helmet. The distance from any edge of an ear aperture to any edge of the helmet shall not be less than 20 mm (0.8 in.).

4.5.2 *Type 2*—The extent of coverage shall include at least all of the area above line BCDGHEF as shown in Fig. 6. This area shall correspond with the headform size with which the protector is to be tested.

4.6 *Attachments*—The components of the fasteners for securing attachments to the shell shall be so attached that the degree of protection afforded the wearer by the protective padding or cushioning material of the helmet is not thereby reduced.

4.7 *Size of Helmets*—Helmets shall be sized in accordance with Table 1.⁵

4.8 *Chin Strap or Neck Strap:*

4.8.1 The chin strap, including the cup, or the neck strap, shall be attached to the helmet so that the helmet remains in its normal position on the player’s head during play and impact conditions.

4.8.2 The chin strap or the neck strap used in combination with the face protector shall satisfy the requirements in 3.1.1.

4.8.3 The minimum width of the chin strap exclusive of the cup shall be 13 mm.

5. **Performance Requirements**

5.1 *General*—Helmets shall be capable of meeting the requirements in this performance specification throughout their full range of adjustment. They shall be capable of meeting the requirements in Sections 11 and 12 at any temperature between –27 to 32°C.

5.2 *Shock Absorption*—The helmet is mounted on a headform that is oriented in different positions and dropped at a specific velocity onto an impact surface. A linear accelerometer mounted at the center of gravity of the headform monitors the acceleration and the time history of impact that are recorded with appropriate instrumentation. Maximum acceleration data obtained by the specified procedures are intended to determine the shock absorption characteristics of the helmet.

5.3 *Chin Strap*—When tested in accordance with 12.7.2.1, the force to separate the strap shall not be less than 50 N (11.2 lbf) nor more than 500 N (112.4 lbf), and the maximum

⁵ Table should be used for information only.

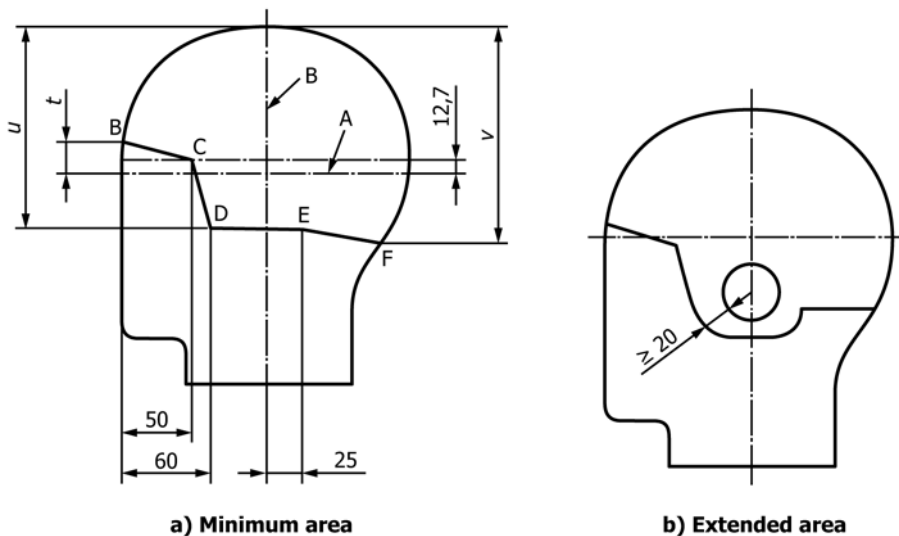

Headform circumference (mm)	Distance (mm)		
	t	u	v
495	24	123	132
535	26	128	140
575	27	129.9	144.9
605	28	132.2	151.2

NOTE 1—A-Reference plane, B-Coronal plane

FIG. 5 Type 1—Area of Coverage

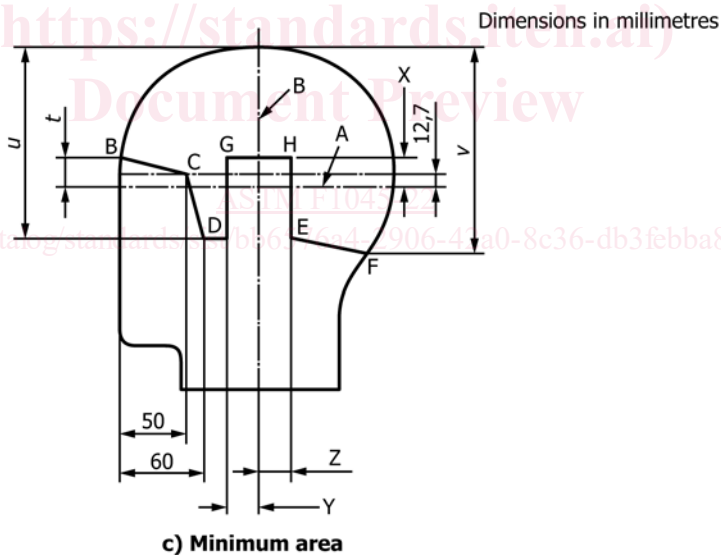

Headform circumference (mm)	Distance (mm)					
	t	u	v	x	y	z
495	24	123	132	—	—	—
535	26	128	140	18	30	50
575	27	129.9	144.9	20	40	55
605	28	132.2	151.2	20	45	55

NOTE 1—A-Reference plane, B-Coronal plane

NOTE 2—Dimension Y and Z are taken and must cover between the reference and the basic plane.

NOTE 3—495 mm Headform does not have Type 2 coverage.

FIG. 6 Type 2—Area of Coverage

displacement of the strap shall not exceed 25.4 mm (1 in.) at a

TABLE 1 Hat Sizes and Head Fittings

NOTE 1—These are U.S. and Canadian hat sizes.

Hat Size	Circumference of Head	
	in.	mm
6	19	483
6 ¹ / ₈	19 ³ / ₈	492
6 ¹ / ₄	19 ¹ / ₂	502
6 ³ / ₈	20 ¹ / ₈	511
6 ¹ / ₂	20 ¹ / ₂	521
6 ⁵ / ₈	20 ⁷ / ₈	530
6 ³ / ₄	21 ¹ / ₄	540
6 ⁷ / ₈	21 ⁵ / ₈	550
7	22	559
7 ¹ / ₈	22 ² / ₈	568
7 ¹ / ₄	22 ³ / ₄	578
7 ³ / ₈	23 ¹ / ₈	587
7 ¹ / ₂	23 ¹ / ₂	597
7 ⁵ / ₈	23 ⁷ / ₈	606
7 ³ / ₄	24 ¹ / ₄	616
7 ⁷ / ₈	24 ⁵ / ₈	625
8	25	635

5.4 *Penetration Resistance Test Requirements*—It shall not be possible to touch the test headform with the curved end of the test stick blade within the required area of coverage, excluding the ear opening.

6. Apparatus

6.1 *Shock Absorption Test*—The apparatus for the shock absorption test shall consist of the following:

6.1.1 *Guide Assembly*—The headform shall be attached to the free fall drop assembly carriage by an adjustable mounting that will allow impacts to be delivered to any prescribed point on the helmet (see Fig. 7). The carriage shall be free to slide on vertical guides. If wires are used, they must be placed under at least 845.2 N (190 lbf) tension (see 12.4 for guide assembly specifications and allowable weight of drop assembly).

6.1.2 *Recording Equipment*—The recording equipment shall meet the following criteria:

6.1.2.1 *Acceleration Transducer*—The linear accelerometer is mounted at the center of gravity of the combined test headform and carriage assembly with the sensitive axis aligned to within 5° of the vertical when the helmet and headform are in the impact position. This transducer shall be capable of

load of 109 N (24.5 lbf). The requirements of 12.7.2.1 shall be met at ambient conditions.

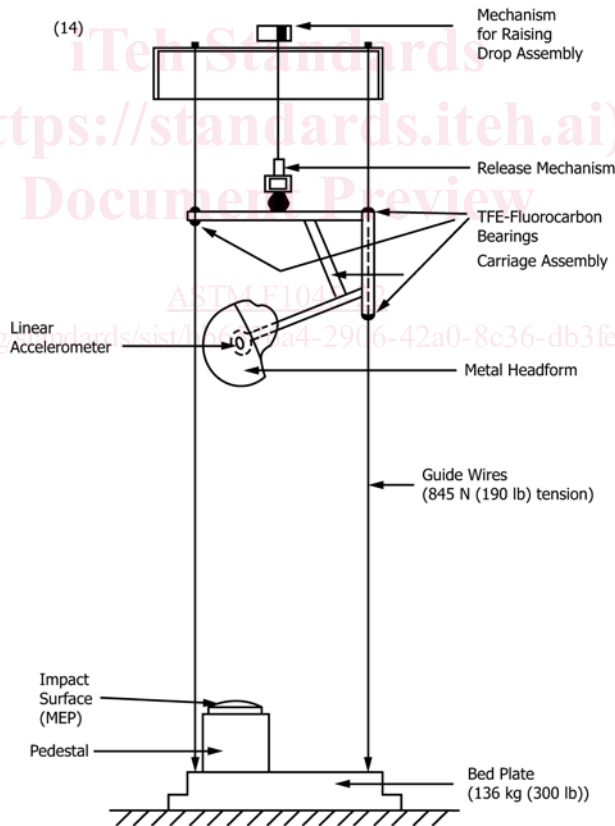

NOTE 1—Rail-guided drop assemblies are also permissible.

FIG. 7 Schematic of Typical Drop Assembly

withstanding a shock of 1000 g without damage and shall have a frequency response (variation $\pm 1.5\%$) over the range from 5 to 900 Hz.

6.1.2.2 *System Accuracy*—The impact recording system shall be capable of measuring shocks of up to 500 g peak acceleration with an accuracy of $\pm 5\%$.

6.1.2.3 *Impact Recording*—The impact shall be recorded on single- or dual-trace storage oscilloscope with 0.1-mV to 20-V deflection factor, 1 to 5-ms sweep speed-division, and 500-kHz bandwidth.⁶

6.1.2.4 *Test Headforms*—Test headforms that correspond to the physical dimensions defined in EN 960:2006 as headform circumferences 495, 535, 575, or 605 mm. The weight of the drop assembly, including the headform, shall be in accordance with 12.4 unless otherwise specified in the individual performance specifications. The test headforms shall include surface markings corresponding to the basic, coronal, midsagittal, and reference planes (see Figs. 2 and 3).

6.1.2.5 *Reference Headforms*—Measuring headforms contoured in the same configuration as the test headforms with circumferences of 495, 535, 575, or 605 mm, as defined in EN 960:2006. The reference headforms shall include surface markings corresponding to the basic, coronal, midsagittal, and reference planes (see Figs. 2-4).

6.1.2.6 *Impact Surface*—The impact surface shall be a flat modular elastomer programmer (MEP) 152.4 mm (6 in.) in diameter and 25.4 mm (1 in.) in thickness which is firmly fixed to the top surface of a flat anvil. The MEP required is a 60 ± 5 Durometer Shore A Hardness impact surface. The base shall consist of a rigid slab weighing at least 136.1 kg (300 lb). The top surface of this base may be used as the flat metal anvil if it is faced with a steel plate with minimum thickness of 25.4 mm (1 in.) and minimum top surface area of 0.09 m² (1 ft²). If a detachable flat metal anvil is used it must have a top surface area of at least 290.3 cm² (45 in.²). The MEP is mounted on an aluminum plate with a minimum thickness of 5.6 mm (0.220 in.) after grinding.

7. Sampling

7.1 Submit at least four specimen helmets for each size to be tested under the various conditions as described in Section 11. One ambient conditioned sample shall be used for both impact testing and the penetration and retention test.

8. Test Specimen

8.1 Test helmets without accessories.

9. Preparation of Apparatus

9.1 Turn on all electronic equipment and allow to warm-up for at least 30 min or as recommended by the manufacturer, whichever time is greater, prior to any testing.

⁶ Equivalent instrumentation capable of recording, displaying, and providing a permanent record of the generated accelerometer shock signal will meet this requirement.

10. Calibration and Standardization

10.1 *Calibration*—Instrumentation used in the testing shall be calibrated to manufacturer's specifications on a periodic basis. The duration of the calibration cycle shall be no more than one year.

10.2 *Impact Attenuation Instrument System Check*—The system instrumentation shall be checked before and after each series of tests by dropping the spherical impactor onto the MEP pad at an impact velocity of 5.2 m/s $\pm 2\%$. Impact velocity shall be measured during the last 40 mm (1.575 in.) of free fall for each test. The weight of the drop assembly (which is the combined weight of the instrumented spherical impactor and supporting assembly) for the drop test shall be 5 ± 0.1 kg (11.00 ± 0.2 lb). Six impacts, at intervals of 75 ± 15 s, shall be performed before and after the testing program. The first three impacts shall be used to warm up the pad; the peak acceleration of the remaining three shall be recorded. The mean of the three post-test results shall not differ by more than 5% from the mean of the three pretest results. Where the difference is greater than 5%, the results shall be discarded and the source of the difference shall be identified and corrected. The tests shall then be repeated with new samples.

10.3 If the maximum g or acceleration time history, or both, are not within the tolerance limits prior to test, adjust or repair the system as necessary.

10.4 If the means of the three peak acceleration values following the test series differ by more than 40 g from the mean of the initial calibration series, discard the entire test series.

11. Conditioning

11.1 Prior to testing, condition each helmet in one of the following ways:

11.1.1 *Ambient Temperature*—The ambient condition of the test laboratory shall be 18 to 22°C, with a maximum relative humidity of 55%. Helmets shall be conditioned in this environment for not less than 4 h.

11.1.2 *Low Temperature*—The low temperature is at a temperature of -23 to -27°C . Helmets shall be conditioned for a period of not less than 4 h nor more than 24 h.

11.1.3 *High Temperature*—The high temperature is at a temperature of 28 to 32°C. Helmets shall be conditioned for a period of not less than 4 h nor more than 24 h.

11.1.4 *Testing for Conditioned Specimens*—Complete all testing on helmets within 5 min after removal from the conditioning environment. Helmets may be returned to the conditioning environment in order to meet this requirement. Prior to the resumption of testing, specimens must remain in the conditioning environment for a minimum of 15 min for each 5-min period they are out of the conditioning environment.

12. Test Methods

12.1 *Testing Environment*—Conduct all testing under the recorded conditions of room temperature and humidity. These conditions must be in accordance with those stated in 11.1.1.

12.2 *Impact Locations and Test Schedule*—The impact locations and test line are defined in this section. The test schedule is described in Table 2.

12.2.1 *Front*—The point on the midsagittal plane which is 50 mm (1.969 in.) above the anterior intersection with the reference plane.

12.2.2 *Side*—The point 25 mm (0.984 in.) above the reference plane and 90° from the anterior intersection of the midsagittal plane and the reference plane (intersection of the reference and coronal planes).

12.2.3 *Rear*—The point at the posterior intersection of the midsagittal and reference planes.

12.2.4 *Crown*—The point where the central vertical axis meets the top of the headform.

12.2.5 *Rear Boss*—A point in a plane 135° (2.36 rad) in a clockwise direction from the anterior intersection of the median and reference planes and on the reference plane.

12.2.6 *Front Boss*—A point in a plane 45° (0.78 rad) from the median plane as measured in a clockwise direction and 25.4 mm (1 in.) above the reference plane.

12.2.7 *Test Line*—Draw test line A-B-C-D-E-F on the headform as indicated in Fig. 8.

12.2.8 *Non-Prescribed Impact Locations*—Non-prescribed impacts shall be located on the headform. The first point of contact with the anvil for any non-prescribed impact location shall be on or above the test line and at least one-fifth of the circumference of the headform from any prior impact location on that helmet. The headform is positioned so that the impact location is the first point of contact with the anvil. The helmet is then placed on the headform as specified by the manufacturer’s head positioning index (HPI). The location of these two non-prescribed impact locations may be identified by the arc distance along the reference plane from the anterior intersection of the midsagittal plane with the reference plane, clockwise or counterclockwise, and the perpendicular arc distance from that point on the reference plane to the non-prescribed impact location.

12.2.9 *Impact Locations on Headform and Helmet*—Determine an impact location on the headform, then mark this location on the headform. Place the helmet on the headform as specified by the manufacturer’s head positioning index (HPI) and mark the corresponding impact location on the helmet before performing the impact. The impact location may be determined and marked first on the helmet and then marked on the headform. If marking the helmet first, make sure the

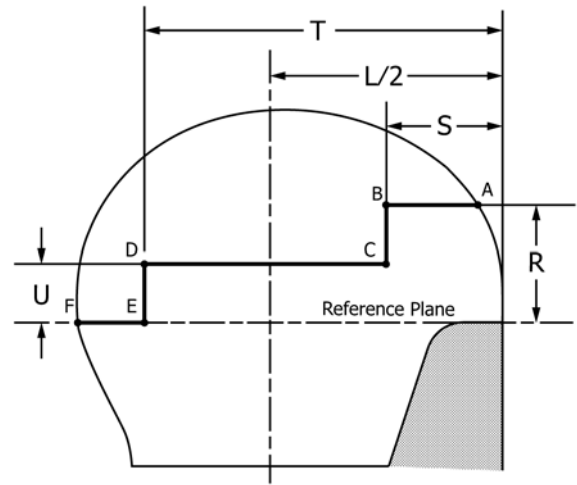

Headform circumference (mm)	Distance (mm)				
	T	L/2	U	R	S
495	137.0	87.8	25.0	50.0	19.5
535	146.5	94.3	25.0	50.0	20.5
575	155.0	100.8	25.0	50.0	20.5
605	161.0	105.6	25.0	50.0	23.5

FIG. 8 Marking the Test Line

corresponding mark on the headform is on or above the test line. Do this for all impact locations.

12.3 *Multiple Impacts*—The time interval between impacts shall be not less than 30 s nor more than 90 s.

12.4 *Headform and Carriage Assembly*—The test headforms shall be made of K1A magnesium material. The headform and carriage assembly shall have a mass of:

- 605 mm headform and carriage assembly = 5.6 ± 0.16 kg
- 575 mm headform and carriage assembly = 4.7 ± 0.14 kg
- 535 mm headform and carriage assembly = 4.1 ± 0.12 kg
- 495 mm headform and carriage assembly = 3.1 ± 0.10 kg

The carriage assembly (excludes ball arm and clamp) shall contribute to no more than 50 % of the total mass.

12.5 *Reference Marking*—Place the complete helmet to be tested on a reference headform that is firmly placed with the basic and reference planes horizontal. Apply a 44.5-N (10-lbf) static load to the crown of the helmet, center the helmet laterally, and adjust it in accordance with the manufacturer’s recommendations. Maintaining the static load, draw a “test

TABLE 2 Protocol for Shock-Absorbing Capacity Testing

Sample No. (for Each Model Size)	Conditioning	Impact Site	Impacts per Site	Drop Velocity
1	Ambient temperature (see 11.1.1)	Crown, one side, front, front boss, rear boss, and rear (see 12.2)	3	4.5 m/s ± 2 %
2	Ambient temperature (see 11.1.1)	Non-prescribed sites 1 and 2 (on or above the test line)	3	4.5 m/s ± 2 %
3	Low temperature (see 11.1.2)	A	3	4.5 m/s ± 2 %
4	High temperature (see 11.1.3)	A	3	4.5 m/s ± 2 %

^A Helmets shall be impacted three times at the site that yielded the highest peak g under ambient temperature conditions.