



Designation: ~~F812–12 (Reapproved 2017)~~ F812 – 12 (Reapproved 2022)

Standard Specification for Surface Discontinuities of Nuts, Inch and Metric Series¹

This standard is issued under the fixed designation F812; the number immediately following the designation indicates the year of original adoption or, in the case of revision, the year of last revision. A number in parentheses indicates the year of last reapproval. A superscript epsilon (ϵ) indicates an editorial change since the last revision or reapproval.

This standard has been approved for use by agencies of the U.S. Department of Defense.

1. Scope*

1.1 This specification establishes allowable limits for the various types of surface discontinuities that may occur during the manufacture and processing of metric-series nuts with nominal diameters 5 mm and larger and inch-series nuts with nominal diameters $\frac{1}{4}$ in. and larger.

1.2 The values stated in either SI (metric) or inch-pound units are to be regarded separately as standard. The values stated in each system are not exact equivalents; therefore, each system must be used independently of the other. Combining values from the two systems may result in nonconformance with the specification.

1.3 When the engineering requirements of the application necessitate control of surface discontinuities on nuts, the purchaser shall specify conformance to this ASTM specification in the original inquiry and purchase order.

1.3.1 When the engineering requirements of the application necessitate that surface discontinuities on nuts be controlled within limits closer than those specified in this specification, the purchaser shall specify the applicable limits in the original inquiry and purchase order.

1.4 The allowable limits established in this specification for metric nuts, with nominal diameters 5 to 24 mm inclusive, are essentially identical with requirements given in ISO/DIS 6157/II. There are no ISO standards for surface discontinuities on metric-series nuts with nominal diameters larger than 24 mm or on any inch-series nuts.

1.5 The following precautionary caveat pertains only to the test method portion, Section 7, of this specification: *This standard does not purport to address all of the safety concerns, if any, associated with its use. It is the responsibility of the user of this standard to establish appropriate safety, health, and environmental practices and determine the applicability of regulatory limitations prior to use.*

1.6 *This international standard was developed in accordance with internationally recognized principles on standardization established in the Decision on Principles for the Development of International Standards, Guides and Recommendations issued by the World Trade Organization Technical Barriers to Trade (TBT) Committee.*

2. Referenced Documents

2.1 ASTM Standards:²

¹ This specification is under the jurisdiction of ASTM Committee F16 on Fasteners and is the direct responsibility of Subcommittee F16.93 on Quality Assurance Provisions for Fasteners.

Current edition approved Sept. 1, 2017/Aug. 1, 2022. Published September 2017/August 2022. Originally approved in 1983. Last previous edition approved in 2012/2017 as ~~F812–12~~F812 – 12(2017). DOI: ~~10.1520/F0812-12R17~~10.1520/F0812-12R22.

² For referenced ASTM standards, visit the ASTM website, www.astm.org, or contact ASTM Customer Service at service@astm.org. For *Annual Book of ASTM Standards* volume information, refer to the standard's Document Summary page on the ASTM website.

*A Summary of Changes section appears at the end of this standard

F606/F606M Test Methods for Determining the Mechanical Properties of Externally and Internally Threaded Fasteners, Washers, Direct Tension Indicators, and Rivets
 F1470 Practice for Fastener Sampling for Specified Mechanical Properties and Performance Inspection
 F1789 Terminology for F16 Mechanical Fasteners

2.2 ISO Standard:

ISO/DIS 6157/II Fasteners, Surface Discontinuities on Nuts³

3. Ordering Information

3.1 Orders for nuts requiring surface discontinuity control shall include:

3.1.1 ASTM designation and date of issue of this specification.

3.1.2 Special requirements, for example, closer discontinuity limits (1.3.1) and inspection sampling plan (6.2)-(6.2).

4. Types of Surface Discontinuities (See Standard F1789 for definitions not provided)

4.1 Crack:

4.1.1 *Quench Cracks*—Typical quench cracks are shown in Fig. 1; limits are specified in 5.2.

4.1.2 *Forging Cracks*—Typical forging cracks are shown in Fig. 2; limits are specified in 5.3.

4.1.3 *Inclusion Cracks*—Normally caused by nonmetallic inclusions or stringers inherent in the raw material. Typical inclusion cracks are shown in Fig. 2; limits are specified in 5.3.

4.1.4 *Locking-Element Cracks*—Occur due to application of pressure when forming the locking element of prevailing torque-type nuts. Such cracks are usually located in the vicinity of the locking element and may be either on the internal or external surface. Typical locking element cracks are shown in Fig. 3; limits are specified in 5.4.

4.1.5 *Washer-Retainer Cracks*—Openings in the lip or hub of metal used to retain a washer on a nut. Washer-retainer cracks may occur when pressure is applied to the lip or hub during assembly of the washer. Typical washer-retainer cracks are shown in Fig. 4; limits are specified in 5.5.

4.2 *Burst*—A typical burst is shown in Fig. 5; limits are specified in 5.6.

4.2.1 *Shear Burst*—A typical shear burst is shown in Fig. 5; limits are specified in 5.6.

4.3 *Seam*—Typical seams are shown in Fig. 6; limits are specified in 5.7.

4.4 *Fold*—Typical folds are shown in Fig. 7; limits are specified in 5.8.

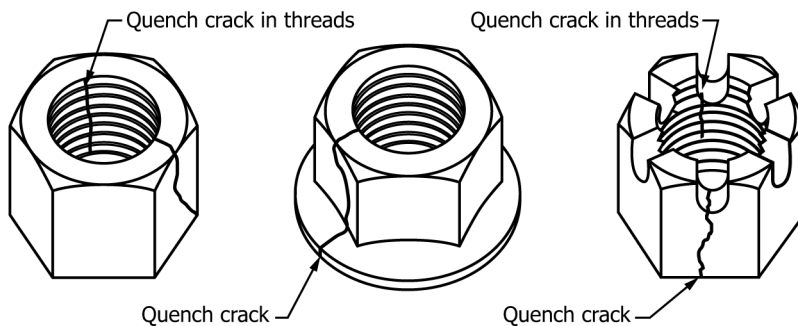

FIG. 1 Typical Quench Cracks in Nuts

³ Available from American National Standards Institute (ANSI), 25 W. 43rd St., 4th Floor, New York, NY 10036, <http://www.ansi.org>.

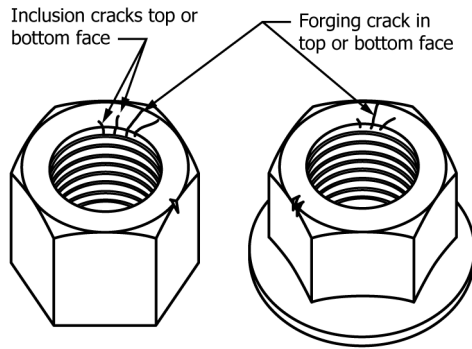

FIG. 2 Typical Forging and Inclusion Cracks in Nuts

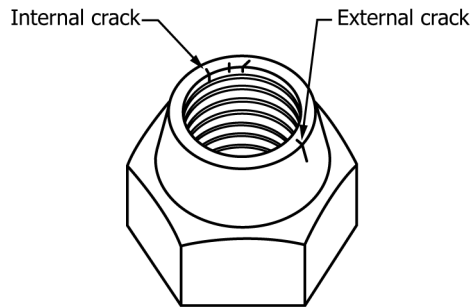

FIG. 3 Typical Locking Element Cracks in Prevailing-Torque Nuts

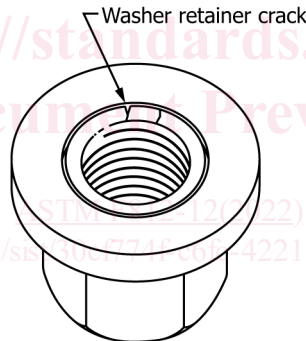

FIG. 4 Typical Washer Retainer Cracks in Nuts

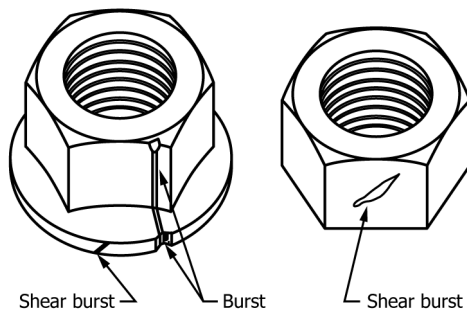

FIG. 5 Typical Bursts and Shear Bursts in Nuts

4.5 *Void*—Voids are produced by marks or impressions of chips (shear burrs) or by rust formation on the raw material. They are not planished during forging. Typical voids are shown in Fig. 8; limits are specified in 5.9.

4.6 *Tool Marks*—Typical tool marks are shown in Fig. 9; limits are specified in 5.10.

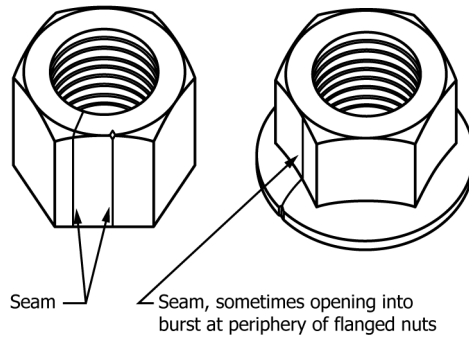

FIG. 6 Typical Seams in Nuts

4.7 *Gouge and Nick*—an indentation on the surface of a fastener produced by impact with another fastener, or from processing equipment during manufacture, handling, or transport.

5. Allowable Limits

5.1 *Letter Definitions*—Throughout the following requirements, D designates the nominal nut size (basic major diameter of thread); D_c designates flange diameter (specified maximum) on flanged nuts; S designates nominal (specified maximum) width across flats. For metric-series nuts, D , D_c , and S are in millimetres; for inch series nuts, D , D_c , and S are in inches.

5.2 *Quench Cracks*—Quench cracks of any depth, any length, or in any location are not permitted.

5.3 *Forging Cracks and Inclusion Cracks*—Forging and inclusion cracks located in the top and bottom faces of nuts of all sizes are permitted provided that (a) there are not more than two cracks that extend from the tapped hole across the full width of the face; (b) no crack extends into the tapped hole beyond the first full thread; (c) no crack in the threads exceeds a depth of 0.5 times the thread height; and (d) the width of any crack does not exceed $0.02 D$ or 0.30 mm or 0.012 in., whichever is greater.

5.3.1 Additionally, hex nuts with nominal diameters 5 to 36 mm inclusive and $\frac{1}{4}$ to $1\frac{1}{2}$ in. inclusive, showing discontinuity indications, shall meet the requirements of the cone proof load test when sampled in accordance with 6.1, using samples selected in accordance with 6.5.2.

5.4 Locking Element Cracks:

5.4.1 Locking-element cracks (or seams) located on the external surface of the locking element of prevailing torque nuts are permitted provided that the net meets all applicable torque requirements.

5.4.1.1 Additionally, hex nuts with nominal diameters 5 to 36 mm inclusive and $\frac{1}{4}$ to $1\frac{1}{2}$ in. inclusive, showing discontinuity indications, shall meet the requirements of the cone proof load test when sampled in accordance with 6.1, using samples selected in accordance with 6.5.2.

5.4.2 Locking-element cracks located on the internal surface (threaded or unthreaded) of prevailing torque nuts are permitted provided that (a) no crack exceeds a length of two thread pitches; (b) no crack shall extend into the thread root; and (c) no crack shall have a width exceeding the following:

5.4.2.1 *Metric-Series Nuts*—0.18 mm for nuts with nominal diameters 5 to 10 mm inclusive, 0.25 mm for nuts with nominal diameters over 10 to 24 mm inclusive, and 0.40 mm for nuts with nominal diameters larger than 24 mm.

5.4.2.2 *Inch Series Nuts*—0.007 in. for nuts with nominal diameters $\frac{1}{4}$ to $\frac{7}{16}$ in. inclusive, 0.010 in. for nuts with nominal diameters over $\frac{7}{16}$ to 1 in. inclusive, and 0.016 in. for nuts with nominal diameters larger than 1 in.

5.5 *Washer-Retainer Cracks*—Washer-retainer cracks are permitted if their location is limited to the contour of the lip or hub used for retaining purposes.

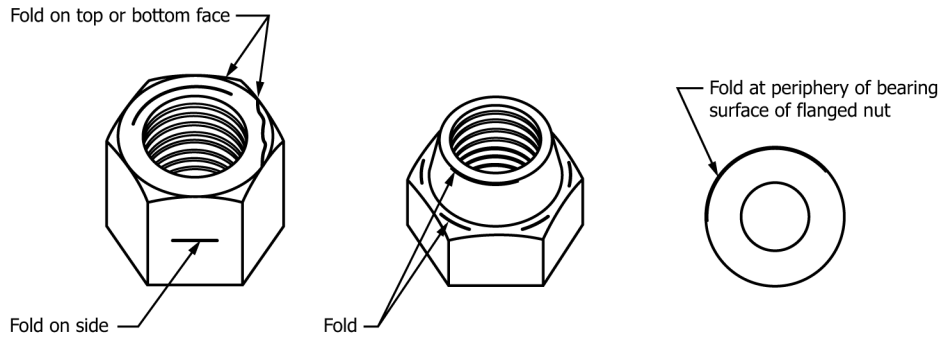

FIG. 7 Typical Folds on Surfaces of Nuts

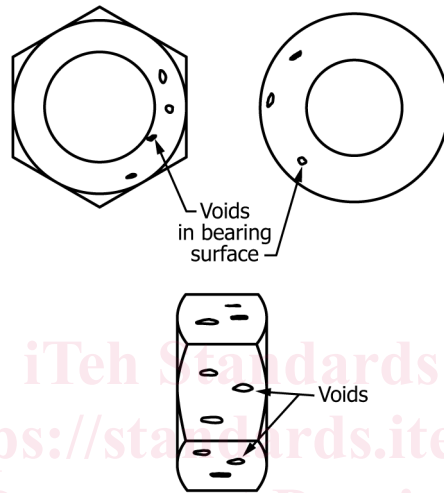

FIG. 8 Typical Voids in Nuts

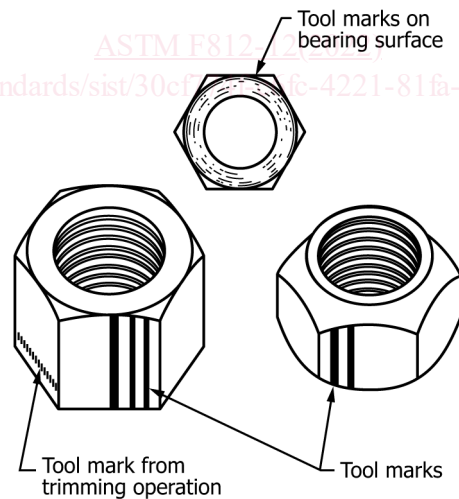

FIG. 9 Typical Tool Marks on Nut Surface

5.6 Bursts and Shear Bursts:

5.6.1 For hex nuts, bursts and shear bursts are permitted provided that (a) no burst or shear burst in the flats extends into the crown (chamfer) circle on the top of the nut or into the bearing circle on the bottom face; (b) no burst or shear burst located at the intersection of the top or bottom face with a wrenching flat has a width greater than 0.25 mm or 0.010 in. plus 0.02 S; and (c) no burst occurring at the intersection of two wrenching flats reduces the width across corners below its specified minimum.