



Designation: ~~D2344/D2344M~~—16 D2344/D2344M – 22

## Standard Test Method for Short-Beam Strength of Polymer Matrix Composite Materials and Their Laminates<sup>1</sup>

This standard is issued under the fixed designation D2344/D2344M; the number immediately following the designation indicates the year of original adoption or, in the case of revision, the year of last revision. A number in parentheses indicates the year of last reappraisal. A superscript epsilon ( $\epsilon$ ) indicates an editorial change since the last revision or reappraisal.

*This standard has been approved for use by agencies of the U.S. Department of Defense.*

### 1. Scope

1.1 This test method determines the short-beam strength of high-modulus fiber-reinforced composite materials. The specimen is a short beam machined from a curved or a flat laminate up to 6.00 mm [0.25 in.] thick. The beam is loaded in three-point bending.

1.2 Application of this test method is limited to continuous- or discontinuous-fiber-reinforced polymer matrix composites, for which the elastic properties are balanced and symmetric with respect to the longitudinal axis of the beam.

1.3 Units—The values stated in either SI units or inch-pound units are to be regarded separately as standard. The values stated in each system may not be necessarily exact equivalents; therefore, to ensure conformance with the standard, each system must shall be used independently of the other. ~~Combining~~ and values from the two systems may result in nonconformance with the standard shall not be combined.

1.3.1 Within the text, the inch-pound units are shown in brackets.

1.4 *This standard does not purport to address all of the safety concerns, if any, associated with its use. It is the responsibility of the user of this standard to establish appropriate ~~safety~~ safety, health, and ~~health~~ environmental practices and determine the applicability of regulatory limitations prior to use.*

1.5 This international standard was developed in accordance with internationally recognized principles on standardization established in the Decision on Principles for the Development of International Standards, Guides and Recommendations issued by the World Trade Organization Technical Barriers to Trade (TBT) Committee.

### 2. Referenced Documents

#### 2.1 ASTM Standards:<sup>2</sup>

- D792 Test Methods for Density and Specific Gravity (Relative Density) of Plastics by Displacement
- D883 Terminology Relating to Plastics
- D2584 Test Method for Ignition Loss of Cured Reinforced Resins
- D2734 Test Methods for Void Content of Reinforced Plastics
- D3171 Test Methods for Constituent Content of Composite Materials
- D3878 Terminology for Composite Materials

<sup>1</sup> This test method is under the jurisdiction of ASTM Committee D30 on Composite Materials and is the direct responsibility of Subcommittee D30.04 on Lamina and Laminate Test Methods.

Current edition approved July 1, 2016 July 15, 2022. Published July 2016 August 2022. Originally approved in 1965. Last previous edition approved in 2013 2016 as ~~D2344—13~~ D2344/D2344M – 16. DOI: ~~10.1520/D2344—D2344M-16~~ 10.1520/D2344\_D2344M-22.

<sup>2</sup> For referenced ASTM standards, visit the ASTM website, www.astm.org, or contact ASTM Customer Service at service@astm.org. For *Annual Book of ASTM Standards* volume information, refer to the standard's Document Summary page on the ASTM website.



- D5229/D5229M Test Method for Moisture Absorption Properties and Equilibrium Conditioning of Polymer Matrix Composite Materials
- D5687/D5687M Guide for Preparation of Flat Composite Panels with Processing Guidelines for Specimen Preparation
- E4 Practices for Force Calibration and Verification of Testing Machines
- E6 Terminology Relating to Methods of Mechanical Testing
- E18 Test Methods for Rockwell Hardness of Metallic Materials
- E122 Practice for Calculating Sample Size to Estimate, With Specified Precision, the Average for a Characteristic of a Lot or Process
- E177 Practice for Use of the Terms Precision and Bias in ASTM Test Methods
- E456 Terminology Relating to Quality and Statistics
- ~~E1309~~E691 Guide for Identification of Fiber-Reinforced Polymer-Matrix Composite Materials in Databases Practice for Conducting an Interlaboratory Study to Determine the Precision of a Test Method (Withdrawn 2015)
- ~~E1434~~ Guide for Recording Mechanical Test Data of Fiber-Reinforced Composite Materials in Databases (Withdrawn 2015)<sup>3</sup>
- ~~E1471~~ Guide for Identification of Fibers, Fillers, and Core Materials in Computerized Material Property Databases (Withdrawn 2015)<sup>3</sup>

### 3. Terminology

3.1 *Definitions*—Terminology D3878 defines the terms relating to high-modulus fibers and their composites. Terminology D883 defines terms relating to plastics. Terminology E6 defines terms relating to mechanical testing. Terminology E456 and Practice E177 define terms relating to statistics. In the event of a conflict between definitions, Terminology D3878 shall have precedence over the other documents.

NOTE 1—If the term represents a physical quantity, its analytical dimensions are stated immediately following the term (or letter symbol) in fundamental dimension form, using the following ASTM standard symbology for fundamental dimensions, shown within square brackets: [M] for mass, [L] for length, [T] for time, [Θ] for thermodynamic temperature, and [nd] for nondimensional quantities. Use of these symbols is restricted to analytical dimensions when used with square brackets, as the symbols may have other definitions when used without the brackets.

#### 3.2 *Definitions of Terms Specific to This Standard:*

3.2.1 *balanced laminate, n*—a continuous fiber-reinforced laminate in which each +0 lamina, measured with respect to the laminate reference axis, is balanced by a −0 lamina of the same material (for example, [0/+45/−45/+45/−45/0]).

3.2.1 *short-beam strength, n*—the shear stress as calculated in Eq 1, developed at the specimen mid-plane at the failure event specified in 11.6.

3.2.1.1 *Discussion*—

Although shear is the dominant applied loading in this test method, the internal stresses are complex, and a variety of failure modes can occur. Elasticity solutions by Berg et al (1)<sup>3</sup>, Whitney (2), and Sullivan and Van Oene (3) have all demonstrated inadequacies in classical beam theory in defining the stress state in the short-beam configuration. These solutions show that the parabolic shear-stress distribution as predicted by Eq 1 only occurs, and then not exactly, on planes midway between the loading nose and support points. Away from these planes, the stress distributions become skewed, with peak stresses occurring near the loading nose and support points. Of particular significance is the stress state local to the loading nose in which the severe shear-stress concentration combined with transverse and in-plane compressive stresses has been shown to initiate failure. However, for the more ductile matrices, plastic yielding may alleviate the situation under the loading nose (1) and allow other failure modes to occur such as bottom surface fiber tension (2). Consequently, unless mid-plane interlaminar failure has been clearly observed, the short-beam strength determined from this test method cannot be attributed to a shear property, and the use of Eq 1 will not yield an accurate value for shear strength.

3.2.3 *symmetric laminate, n*—a continuous fiber-reinforced laminate in which each ply above the mid-plane is identically matched (in terms of position, orientation, and mechanical properties) with one below the mid-plane.

#### 3.3 *Symbols:*

- $b$ —specimen width:width
- CV—sample coefficient of variation (in percent):percent
- $F^{sbs}$ —short-beam strength:strength
- $h$ —specimen thickness:thickness

<sup>3</sup>The last approved version of this historical standard is referenced on [www.astm.org](http://www.astm.org).

- $n$ —number of specimens:specimens
- $P_m$ —maximum load observed during the test:test
- $x_i$ —measured or derived property for an individual specimen from the sample population:population
- $\bar{x}$ —sample mean (average):(average)

**4. Summary of Test Method**

4.1 The short-beam test specimens (Figs. 1-4) are center-loaded as shown in Figs. 5 and 6. The specimen ends rest on two supports that allow lateral motion, the load being applied by means of a loading nose directly centered on the midpoint of the test specimen.

**5. Significance and Use**

5.1 In most cases, because of the complexity of internal stresses and the variety of failure modes that can occur in this specimen, it is not generally possible to relate the short-beam strength to any one material property. However, failures are normally dominated by resin and interlaminar properties, and the test results have been found to be repeatable for a given specimen geometry, material system, and stacking sequence (4).

5.2 Short-beam strength determined by this test method can be used for quality control and process specification purposes. It can also be used for comparative testing of composite materials, provided that failures occur consistently in the same mode (5).

5.3 This test method is not limited to specimens within the range specified in Section 8, but is limited to the use of a loading span length-to-specimen thickness ratio of 4.0 and a minimum specimen thickness of 2.0 mm [0.08 in.].

**6. Interferences**

6.1 Accurate reporting of observed failure modes is essential for meaningful data interpretation, in particular, the detection of initial damage modes.

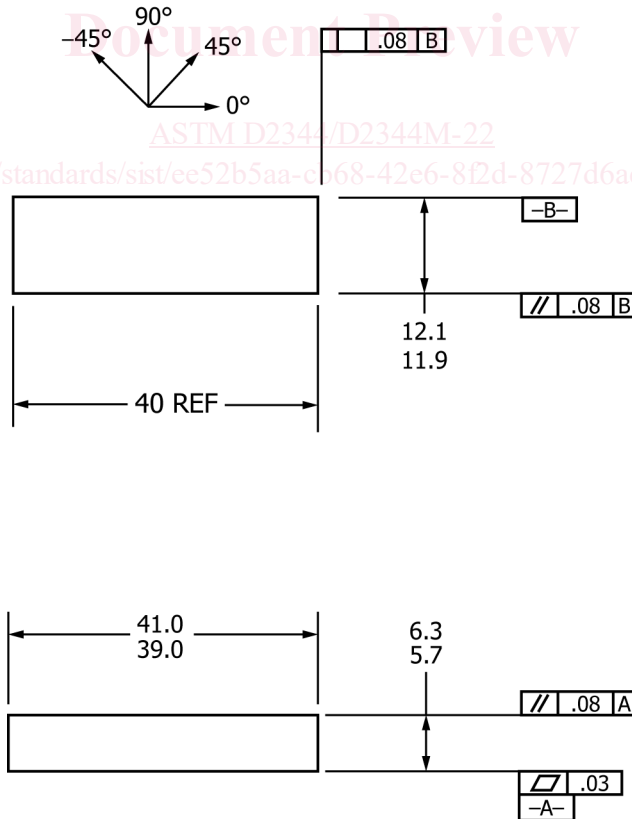

NOTE 1—Drawing interpretation per ANSI Y14.5-1982 and ANSI/ASM B46.1-1986.

NOTE 2—Ply orientation tolerance  $\pm 0.5^\circ$  relative to -B-.

**FIG. 1 Flat Specimen Configuration (SI)**

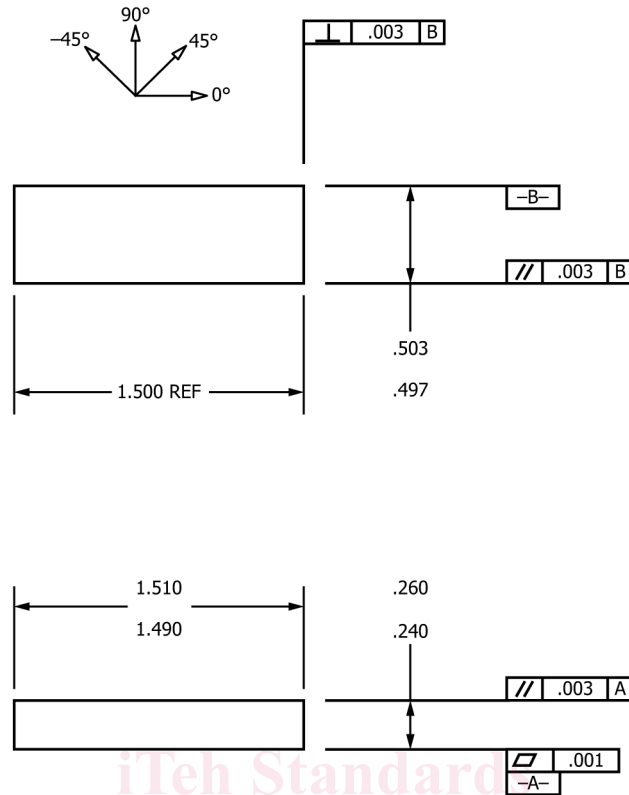

NOTE 1—Drawing interpretation per ANSI Y14.5-1982 and ANSI/ASME B46.1-1986.

NOTE 2—Ply orientation tolerance  $\pm 0.5^\circ$  relative to -B-.

FIG. 2 Flat Specimen Configuration (Inch Pound)

## 7. Apparatus

7.1 *Testing Machine*, properly calibrated, which can be operated at a constant rate of crosshead motion, and which the error in the loading system shall not exceed  $\pm 1\%$ . The load-indicating mechanism shall be essentially free of inertia lag at the crosshead rate used. Inertia lag may not exceed 1% of the measured load. The accuracy of the testing machine shall be verified in accordance with Practices E4.

7.2 *Loading Nose and Supports*, as shown in Figs. 5 and 6, shall be  $6.00 \pm 0.50$  mm [ $0.250 \pm 0.020$  in.] and  $3.00 \pm 0.40$  mm [ $0.125 \pm 0.010$  in.] diameter cylinders, respectively, with a hardness of 60 to 62 HRC, as specified in Test Methods E18, and shall have finely ground surfaces free of indentation and burrs with all sharp edges relieved. The loading configuration shown in Fig. 5 is recommended for curved specimens with a radius  $r$  to specimen thickness  $h$  ratio of  $r/h$  of 5 or less. The loading configuration shown in Fig. 6 is recommended for flat specimens as well as curved specimens with a  $r/h$  ratio of greater than 5.

7.3 *Micrometers and Calipers*—A micrometer with a 4 to 7 mm [0.16 to 0.280.32 in.] nominal diameter ball interface or a flat anvil interface shall be used to measure the specimen width and thickness. A ball interface is recommended for thickness measurements when at least one surface is irregular (e.g. (for example, a coarse peel ply surface which is neither smooth nor flat). A micrometer or caliper with a flat anvil interface shall be used for measuring width and length. The use of alternative measurement devices is permitted if specified (or agreed to) by the test requestor and reported by the testing laboratory. The accuracy of the instrument(s) shall be suitable for reading within 1% of the specimen dimensions. For typical specimen geometries, an instrument with an accuracy of  $\pm 0.0025$  to  $\pm 0.0025$  mm [ $\pm 0.0001$  in.] is adequate for width and thickness measurements, while an instrument with an accuracy of  $\pm 0.025$  mm [ $\pm 0.001$  in.] is adequate for measurement of width and length.

7.4 *Conditioning Chamber*—When conditioning materials at nonlaboratory environments, a temperature/vapor-level-controlled environmental conditioning chamber is required that shall be capable of maintaining the required temperature to within  $\pm 3^\circ\text{C}$  ( $\pm 5^\circ\text{F}$ )  $\pm 3^\circ\text{C}$  ( $\pm 5^\circ\text{F}$ ) and the required vapor level to within  $\pm 3\%$ . Chamber conditions shall be monitored either on an automated continuous basis or on a manual basis at regular intervals.

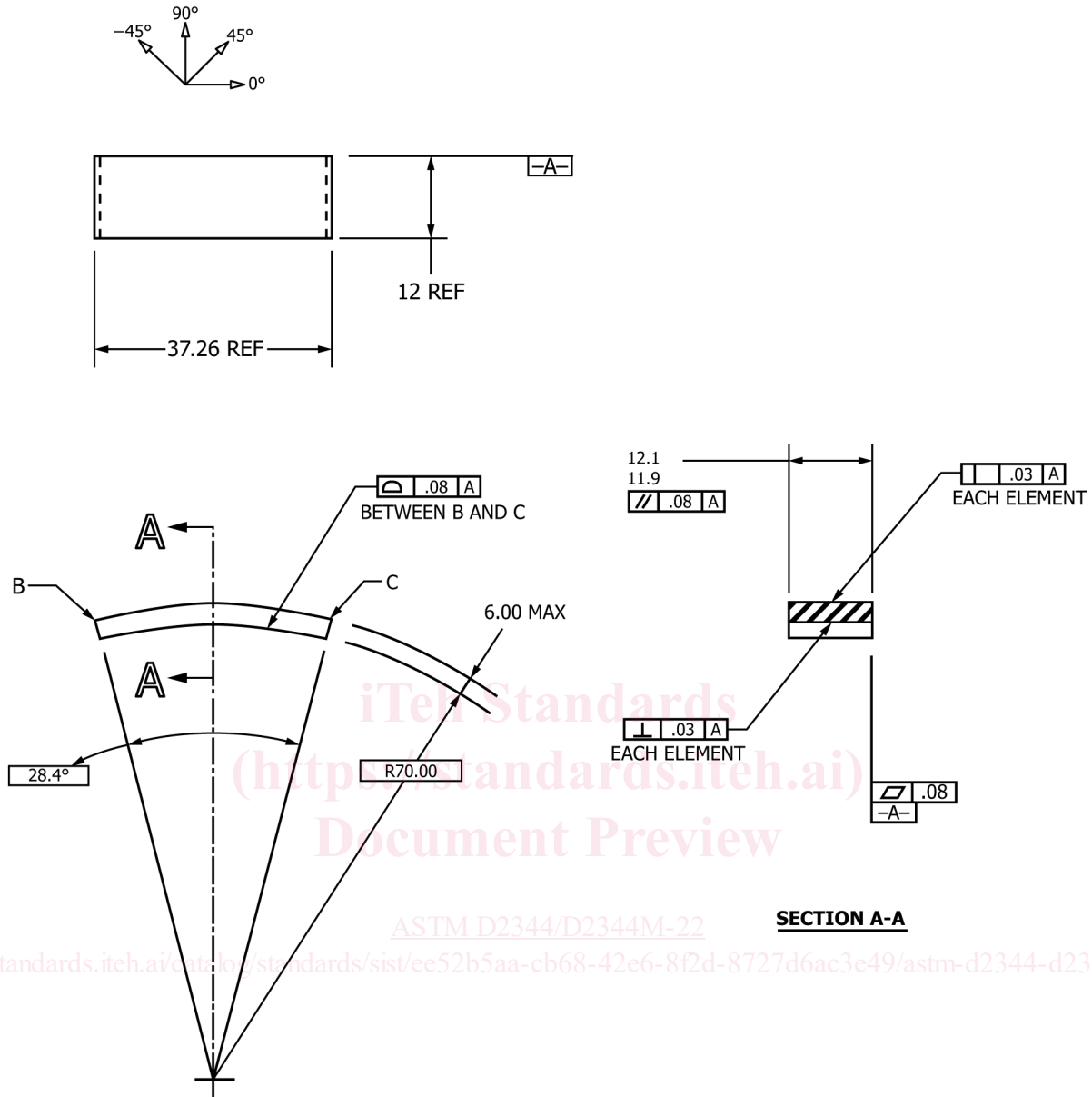

NOTE 1—Drawing interpretation per ANSI Y14.5-1982 and ANSI/ASM B46.1-1986.

NOTE 2—Ply orientation tolerance  $\pm 0.5^\circ$  relative to -A-.

FIG. 3 Curved Specimen Configuration (SI)

7.5 *Environmental Test Chamber*—An environmental test chamber is required for test environments other than ambient testing laboratory conditions. This chamber shall be capable of maintaining the test specimen at the required test environment during the mechanical test method.

## 8. Sampling and Test Specimens

8.1 *Sampling*—Test at least five specimens per test condition unless valid results can be gained through the use of fewer specimens, as in the case of a designed experiment. For statistically significant data, consult the procedures outlined in Practice E122. Report the method of sampling.

8.2 *Geometry*:

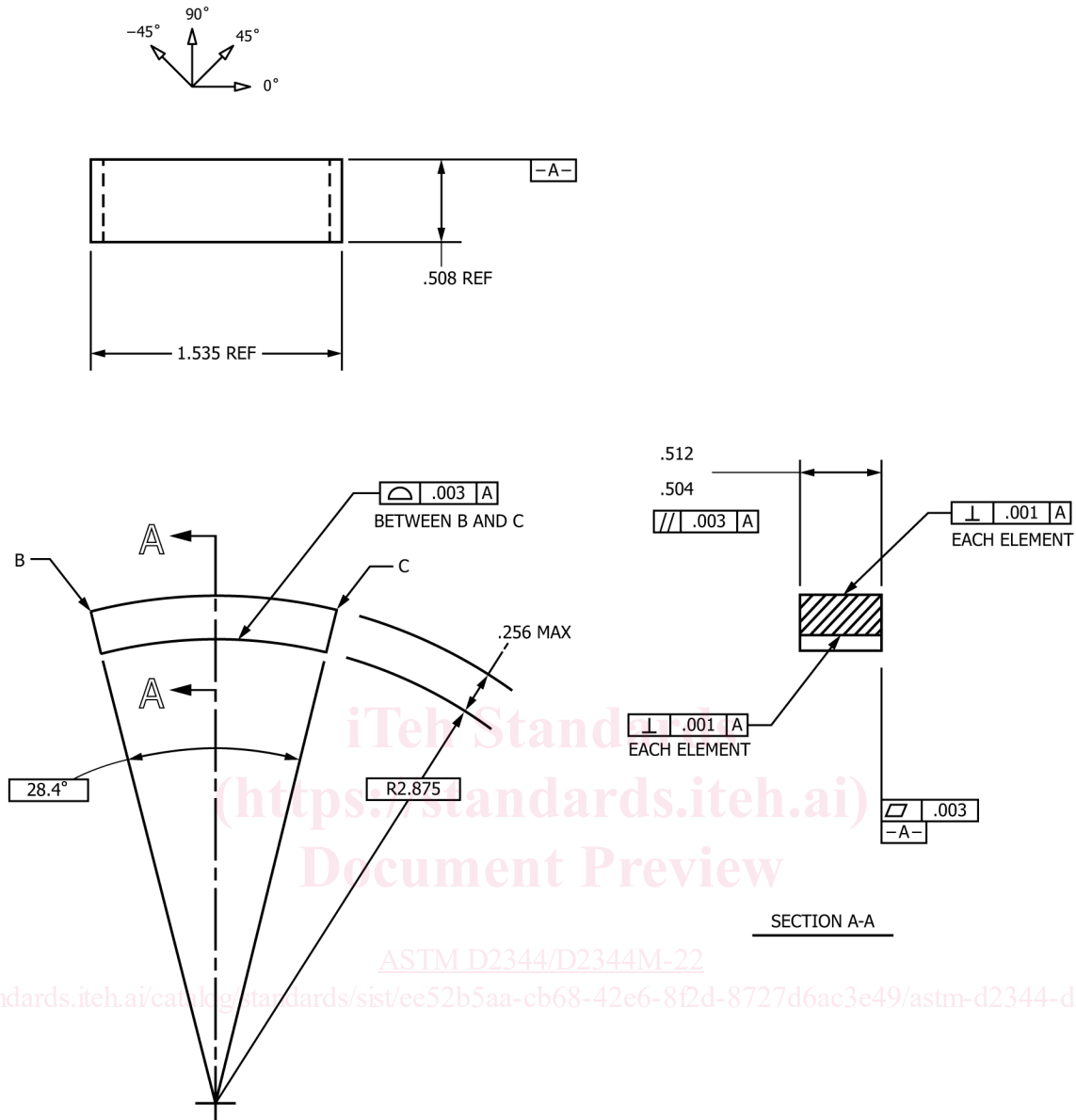

NOTE 1—Drawing interpretation per ANSI Y14.5-1982 and ANSI/ASME B46.1-1986.

NOTE 2—Ply orientation tolerance  $\pm 0.5^\circ$  relative to -A-.

FIG. 4 Curved Specimen Configuration (Inch Pound)

8.2.1 *Laminate Configurations*—Both multidirectional and pure unidirectional laminates can be tested, provided that there are at least 10 % 0° fibers in the span direction of the beam (preferably well distributed through the thickness), and that the laminates are both balanced and symmetric with respect to the span direction of the beam.

8.2.2 *Specimen Configurations*—Typical configurations for the flat and curved specimens are shown in Figs. 1-4. For specimen thicknesses other than those shown, the following geometries are recommended:

$$\begin{aligned} \text{Specimen length} &= \text{thickness} \times 66; \\ \text{Specimen width, } b &= \text{thickness} \times 2.0 \end{aligned}$$

NOTE 2—A discussion of width-to-thickness effects is available in Adams and Lewis (6).

8.2.2.1 For curved beam specimens, it is recommended that the arc should not exceed 30°. Also, for these specimens, the specimen length is defined as the minimum chord length.

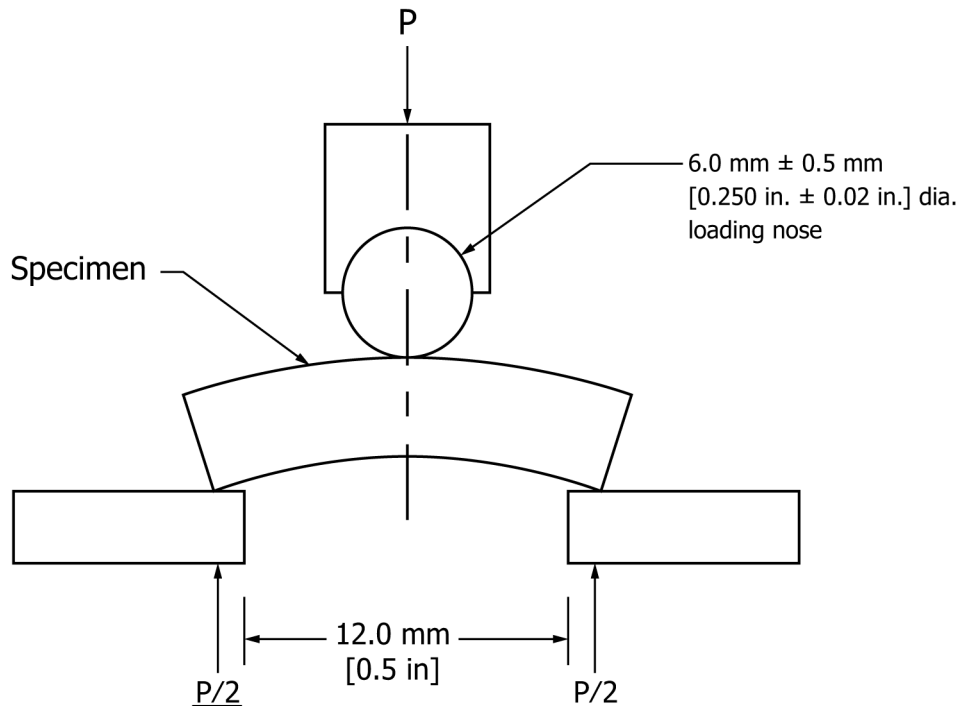

FIG. 5 Horizontal Shear Curved Laminate Load Diagram (Curved Beam)

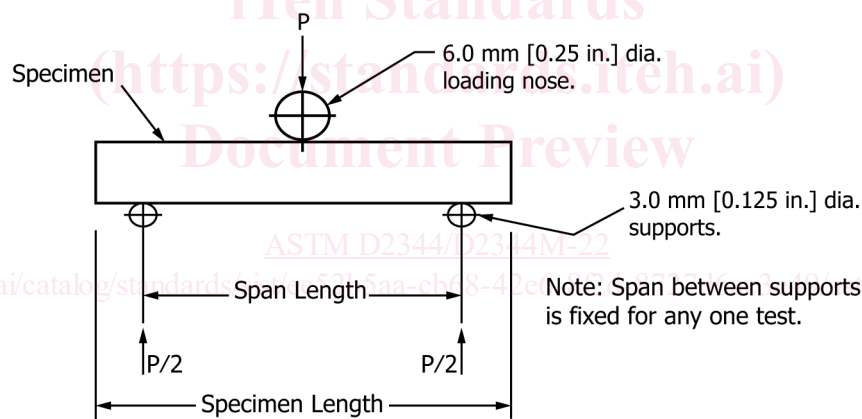

FIG. 6 Horizontal Shear Flat Laminate Load Diagram (Flat Laminate)

8.3 *Specimen Preparation*—Guide [D5687/D5687M](#) provides recommended specimen preparation practices and should be followed where practical.

8.3.1 *Laminate Fabrication*—Laminates may be hand-laid, filament-wound or tow-placed, and molded by any suitable laminating means, such as press, bag, autoclave, or resin transfer molding.

8.3.2 *Machining Methods*—Specimen preparation is important for these specimens. Take precautions when cutting specimens from the rings or plates to avoid notches, undercuts, rough or uneven surfaces, or delaminations as a result of inappropriate machining methods. Obtain final dimensions by water-lubricated precision sawing, milling, or grinding. The use of diamond tooling has been found to be extremely effective for many material systems. Edges should be flat and parallel within the specified tolerances.

8.3.3 If specific gravity, density, reinforcement volume, or void volume are to be reported, then obtain these samples from the same panels being tested. Specific gravity and density may be evaluated by means of Test Methods [D792](#). Volume percent of the constituents may be evaluated by one of the matrix digestion procedures of Test Methods [D3171](#) or, for certain reinforcement