



Designation: F945—12 (Reapproved 2019) F945 – 22

Standard Test Method for Stress-Corrosion of Titanium Alloys by Aircraft Engine Cleaning Materials¹

This standard is issued under the fixed designation F945; the number immediately following the designation indicates the year of original adoption or, in the case of revision, the year of last revision. A number in parentheses indicates the year of last reapproval. A superscript epsilon (ϵ) indicates an editorial change since the last revision or reapproval.

This standard has been approved for use by agencies of the U.S. Department of Defense.

INTRODUCTION

Chemical solutions and compounds used for preinspection cleaning or for preservation of titanium alloy aircraft turbine engine parts shall be subject to qualification requirements of this test method.

1. Scope

1.1 This test method establishes a test procedure for determining the propensity of aircraft turbine engine cleaning and maintenance materials for causing stress corrosion cracking of titanium alloy parts.

1.2 The evaluation is conducted on representative titanium alloys by determining the effect of contact with cleaning and maintenance materials on tendency of prestressed titanium alloys to crack when subsequently heated to elevated temperatures.

1.3 Test conditions are based upon manufacturer's maximum recommended operating solution concentration.

1.4 *Units*—The values stated in inch-pound units are to be regarded as standard. The values given in parentheses are mathematical conversions to SI units that are provided for information only and are not considered standard.

1.5 *This standard does not purport to address all of the safety concerns, if any, associated with its use. It is the responsibility of the user of this standard to establish appropriate safety, health, and environmental practices and determine the applicability of regulatory limitations prior to use.* For specific precautionary statements, see 5.3 and 5.6.

1.6 *This international standard was developed in accordance with internationally recognized principles on standardization established in the Decision on Principles for the Development of International Standards, Guides and Recommendations issued by the World Trade Organization Technical Barriers to Trade (TBT) Committee.*

2. Referenced Documents

2.1 *ASTM Standards:*²

D740 Specification for Methyl Ethyl Ketone

D841 Specification for Nitration Grade Toluene

D1193 Specification for Reagent Water

¹ This test method is under the jurisdiction of ASTM Committee F07 on Aerospace and Aircraft and is the direct responsibility of Subcommittee F07.07 on Qualification Testing of Aircraft Cleaning Materials.

Current edition approved May 1, 2019; Sept. 1, 2022. Published June 2019; September 2022. Originally approved in 1985. Last previous edition approved in 2012 as F945—12; F945 – 12(2019). DOI: 10.1520/F0945-12R19; 10.1520/F0945-22.

² For referenced ASTM standards, visit the ASTM website, www.astm.org, or contact ASTM Customer Service at service@astm.org. For *Annual Book of ASTM Standards* volume information, refer to the standard's Document Summary page on the ASTM website.

2.2 SAE Aerospace Material Specifications:³

[AMS 4911 Sheet, Strip and Plate-6AL-4V Annealed 0.050" Thick](#)

[AMS 4916 Sheet, Strip, and Plate-8AL 1MO 1V, Duplex Annealed 0.050" Thick](#)

[AMS 4919 Sheet, Strip, and Plate-6AL 2 Sn, 4 Zr, 2 Mo, Duplex Annealed 0.050" Thick](#)

3. Significance and Use

3.1 Because of the tendency of prestressed titanium alloy parts to crack if heated while in contact with certain chemical reagents, it is necessary to ensure that cleaning and maintenance materials will not initiate stress corrosion of titanium alloys under controlled conditions. For test specimens, two common titanium alloys are selected, one that is very susceptible (~~AMS 4916~~ AMS 4916 or AMS 4919) and one that is not very susceptible (AMS 4911) to stress corrosion cracking.

4. Apparatus

4.1 *Measuring Device* capable of linear measurement with a ~~± 0.01 in. (± 0.25 mm)~~ ± 0.01 in. (± 0.25 mm) tolerance.

4.2 *Press Forming Apparatus*⁴ with ~~0.56 in. (14 mm)~~ 0.56 in. (14 mm) diameter mandrel capable of producing approximately 65° bends in ~~0.050 in. (1.25 mm)~~ 0.050 in. (1.25 mm) titanium alloy sheet specimens.

4.3 *Beakers or Small Tanks* for containment of cleaning, rinsing, and test solutions, appropriately lined to prevent contamination of the solutions by container materials.

4.4 *Vise*, capable of precise manipulation at jaw opening of 0.65 in. (16.5 mm). A standard sheet metal worker's vise with a ~~3 in.~~ 3 in. jaw has been found satisfactory.

4.5 *Air Circulation Furnace* capable of operating at 900 °F (480 °C) with control to ± 20 °F (10 °C).

4.6 *Magnifier* capable of 20-diameters magnification.

4.7 *Microscope* capable of 500-diameters magnification.

4.8 *Bolt*, stainless steel, ~~0.25 in. (6 mm)~~ 0.25 in. (6 mm) diameter with stainless steel washers and nut.

4.9 *Test Specimens*, ~~AMS 4911 and AMS 4916 Titanium Alloys~~ or AMS 4919 Titanium Alloys with specimens prepared from the same sheet stock for each alloy and cut parallel to the rolling direction to the dimensions of Fig. 1. The specimen edges shall not be deburred or otherwise relieved before testing. Specimens shall not be machined or mechanically treated in any way such as benching, sanding, etc.

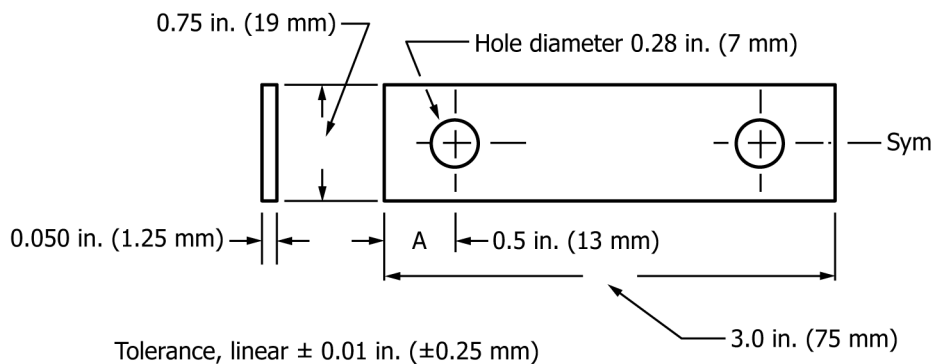

FIG. 1 U-Bend Specimen Dimensions

³ Available from Society of Automotive Engineers, 400 Commonwealth Dr., Warrendale, PA 15096.

⁴ The sole source of supply of the apparatus (A laboratory bench hydraulic press ENER PAC Model No. P-39 has been found satisfactory) known to the committee at this time is Black Hawk Industrial Products, Butler, WI 53007. If you are aware of alternative suppliers, please provide this information to ASTM International Headquarters. Your comments will receive careful consideration at a meeting of the responsible technical committee,¹ which you may attend.

4.10 *Cotton Gloves*, white.

4.11 *Volumetric Flask of Low Sodium Glass with Ground Glass Stopper*, 1000 and ~~100 mL~~, 100 mL.

4.12 *Volumetric Pipette*, ~~10 mL~~, 10 mL.

4.13 *Volumetric Flask with Ground Glass Stopper*, ~~100 mL~~, 100 mL.

5. Reagents and Materials

5.1 *Purity of Reagent*—Reagent grade chemicals shall be used in all cases. Unless otherwise indicated, it is intended that all reagents shall conform to the specifications of the Committee on Analytical Reagents of the American Chemical Society, where such specifications are available.⁵ Other grades may be used, provided it is first ascertained that the reagent is of sufficiently high purity to permit its use without lessening the accuracy of analysis.

5.2 *Purity of Water*—Unless otherwise indicated, references to water shall be understood to mean reagent water conforming to Specification **D1193** Type IV.

5.3 *Cleaning Solution*, mix 35 volume % nitric acid (42° Be') (**Warning**—See Annex **A1.2**) and 3 volume % ~~hydro~~-hydro-fluoric acid (70 %) or 4.5 volume % hydrofluoric acid (49 %). (**Warning**—See Annex **A1.3**) with reagent water.

5.4 *2-Propanol (Isopropanol)*, HPLC grade.

5.5 *Salt Solutions*:

5.5.1 100-ppm sodium chloride solution in 2-propanol.

5.5.1.1 *Preparation of 1000-ppm NaCl in 2-Propanol Stock Solution (Shelf Life Three Months in Flask, see 4.11)*—Weigh ~~1.000 g~~ 1.000 g NaCl \pm 0.001 g into a ~~1000 mL~~ 1000 mL volumetric flask. Add 250- \pm 25-mL reagent water and stir to dissolve. Fill to the mark with 2-propanol and mix.

5.5.1.2 *Preparation of 100-ppm NaCl Test Solution (Shelf Life Seven Days in Flask, see 4.11)*—Pipette 10 mL of the stock solution into a ~~100 mL~~ 100 mL volumetric flask. Fill to the mark with 2-propanol and mix.

5.5.2 *Preparation of 3 Weight % Sodium Chloride in 2-Propanol (Shelf Life Three Months)*—Weight ~~3.00 g~~ 3.00 g NaCl into a ~~100 mL~~ 100 mL volumetric flask (see 4.13). Add about 50 mL of reagent water and stir to dissolve. Fill to the mark with 2-propanol and mix.

5.6 *Solvent*, toluene conforming to Specification **D841** or methyl ethyl ketone conforming to Specification **D740**. (**Warning**—See Annex **A1.1**).

NOTE 1—The use of 2-propanol is important to ensure an even distribution of the salt by evaporating quickly. This decreases the effect of a “drop” at the bottom of the specimens.

6. Precleaning Test Specimens

6.1 Handling contamination and shop soils shall be removed by washing in a solvent. Dry thoroughly.

⁵ *Reagent Chemicals, American Chemical Society Specifications*, American Chemical Society, Washington, DC. For suggestions on the testing of reagents not listed by the American Chemical Society, see *Analar Standards for Laboratory Chemicals*, BDH Ltd., Poole, Dorset, U.K., and the *United States Pharmacopeia and National Formulary*, U.S. Pharmacopeial Convention, Inc. (USPC), Rockville, MD.

7. Specimen Fabrication

7.1 With the short specimen axis as the bend axis, press form the specimen around an approximately $0.45\text{-in. (14\text{-mm})}$ diameter mandrel in one operation so that an unrestrained preform angle of approximately 65° is obtained. See Fig. 2.

7.2 Clean the specimen preform by immersing in cleaning solution of 5.3 for 15 ± 5 s. Rinse in clean water, then in reagent water. Air dry with the bend zone up. Use white cotton gloves when handling specimens and do not touch the bend zone after cleaning.

7.3 Final U-bend configuration shall be accomplished by bending the free ends of the preform together in a vise until the distance between the free ends is reduced to $0.65\text{ in.} \pm 0.05$ (16.5 ± 1 mm).

7.4 Restrain the test specimen with sides approximately parallel by fastening the ends with a clean $0.25\text{-in. (6\text{-mm})}$ diameter stainless steel bolt with washers. Unplated stainless steel nuts may be used. See Fig. 3.

7.5 Load the specimen by tightening the bolt until the legs are 0.535 ± 0.005 in. (13.6 ± 0.10 mm) apart. See Fig. 3.

NOTE 2—Before acquiring titanium alloy sheet for the fabrication of test panels, notably AMS 4916, 4916 or AMS 4919, it is recommended to establish that susceptibility for SCC is present according to Section 8, using the appropriate salt solutions. If no cracking is exhibited, the test must be repeated using another lot of AMS 4916 or AMS 4919 titanium alloy.

8. Procedure (See Fig. 4.)

8.1 Test a minimum of nine specimens of each alloy using the following procedure.

8.1.1 To establish acceptability of the titanium alloy sheet materials for use in these tests, test three restrained test specimens of each alloy without contacting any test solution after acid cleaning.

8.1.2 To establish sensitivity of the titanium alloy sheet materials to stress corrosion attack, wet three restrained test specimens of AMS 4916 or AMS 4919 alloy by immersing in the 100-ppm sodium chloride solution and three restrained test specimens of AMS 4911 alloy by immersing in the solution of 3 weight % sodium chloride. Hang to dry with the bend zone down. Remove and test as in 8.2.

NOTE 3—Control specimens must be included in each actual test to ensure proper materials, technique, and examination.

8.1.3 To evaluate the effect of the candidate solution, wet three restrained test specimens of each alloy by immersing in the candidate solution at the maximum recommended concentration. Hang to dry with the bend zone down and test as in 8.2.

8.2 Heat the restrained specimens in an air circulation furnace in accordance with method(s) to be specified by the purchaser as follows:

8.2.1 *Method A*—Heat at 900 ± 20 °F (480 ± 10 °C) for 8 ± 0.2 h.

8.2.2 *Method B*—Removed. Use Method A.

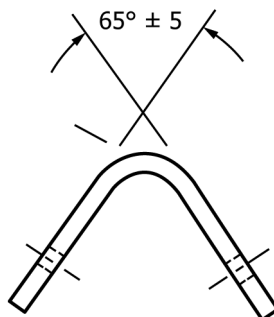

FIG. 2 Brake Formed U-Bend Specimen

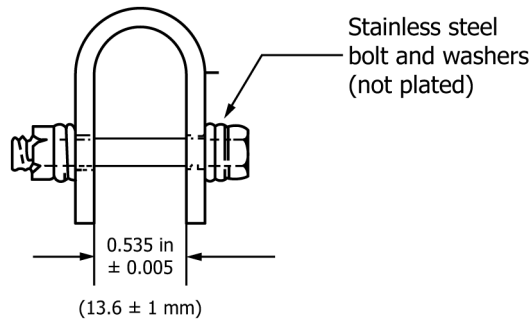

FIG. 3 Loaded U-Bend Specimen

8.2.3 After heating, remove the specimens from the furnace, allow to cool, and inspect for cracks.

8.3 *Preliminary Evaluation*—Inspect all of the restrained specimens visually using 20-diameters magnification.

8.3.1 If cracks are found on the untreated (control) specimens, repeat the entire stress corrosion test using acceptable titanium alloy sheet material.

8.3.2 If cracks are found on all candidate-solution-treated specimens, this shall be cause for rejection of the candidate cleaning material.

8.3.3 All restrained specimens not found to be cracked during visual inspection at 20-diameters magnification prepare for further inspection as follows:

8.3.3.1 Remove the bolt restraints.

8.3.3.2 Rinse in warm tap water; do not permit to dry.

8.3.3.3 While wet, immerse in acid cleaning solution of 5.3 for 15 ± 5 s.

8.3.3.4 Rinse in tap water and air dry.

8.3.3.5 Inspect metallographically as in 8.4.1.

8.4 *Metallographic Inspection.*

8.4.1 Make a cross section of each specimen at the bend normal to the bend axis (parallel to the test panel long axis). Cut the specimens using a fine-tooth hacksaw or other apparatus capable of producing a smooth cut with minimal disturbance of specimen edges. Make the cut approximately at the center axis in line with the holes. The metallographic specimen shall encompass material from the bend to a point approximately 0.5 in. (13 mm) from the bend. Examine the cut surface over the ~~0.5-in. (13-mm)~~ 0.5 in. (13 mm) distance on both sides of the bend zone at 500 diameters following metallographic preparation appropriate to the specimen alloy composition.

8.5 For the Metallographic Inspection Chart, see Fig. 4.

9. Determination of Test Results

9.1 Detection of cracks on either the tension or compression surfaces of any of the untreated (control) specimens shall be cause to repeat the entire stress corrosion test using acceptable titanium alloy sheet material.

9.2 Failure to detect cracks on either the tension or compression surfaces of all of the NaCl-solution-treated specimens shall be cause to repeat the entire stress corrosion test using titanium alloy sheet having a demonstrated susceptibility to stress corrosion cracking.