



Designation: D1120 – 22

# Standard Test Method for Boiling Point of Engine Coolants<sup>1</sup>

This standard is issued under the fixed designation D1120; the number immediately following the designation indicates the year of original adoption or, in the case of revision, the year of last revision. A number in parentheses indicates the year of last reapproval. A superscript epsilon ( $\epsilon$ ) indicates an editorial change since the last revision or reapproval.

*This standard has been approved for use by agencies of the U.S. Department of Defense.*

## 1. Scope\*

1.1 This test method covers the determination of the equilibrium boiling point of engine coolants. The equilibrium boiling point indicates the temperature at which the sample will start to boil in a cooling system under equilibrium conditions at atmospheric pressure.

NOTE 1—Engine coolants may also be marketed in a ready-to-use form (prediluted). This test procedure is applicable to diluted solutions as well as to concentrates.

NOTE 2—The procedure for obtaining a representative test sample of a coolant solution that contains an antileak additive is found in Practice D1176.

1.2 The values stated in SI units are to be regarded as standard. The values given in parentheses after SI units are provided for information only and are not considered standard.

1.3 *This standard does not purport to address all of the safety concerns, if any, associated with its use. It is the responsibility of the user of this standard to establish appropriate safety, health, and environmental practices and determine the applicability of regulatory limitations prior to use.*

1.4 *This international standard was developed in accordance with internationally recognized principles on standardization established in the Decision on Principles for the Development of International Standards, Guides and Recommendations issued by the World Trade Organization Technical Barriers to Trade (TBT) Committee.*

## 2. Referenced Documents

### 2.1 ASTM Standards:<sup>2</sup>

D1176 Practice for Sampling and Preparing Aqueous Solutions of Engine Coolants or Antirusts for Testing Purposes  
E1 Specification for ASTM Liquid-in-Glass Thermometers

<sup>1</sup> This test method is under the jurisdiction of ASTM Committee D15 on Engine Coolants and Related Fluids and is the direct responsibility of Subcommittee D15.03 on Physical Properties.

Current edition approved Sept. 1, 2022. Published September 2022. Originally approved in 1950 as D1120 – 50 T. Last previous edition approved in 2017 as D1120-17. DOI: 10.1520/D1120-22.

<sup>2</sup> For referenced ASTM standards, visit the ASTM website, www.astm.org, or contact ASTM Customer Service at service@astm.org. For *Annual Book of ASTM Standards* volume information, refer to the standard's Document Summary page on the ASTM website.

E230/E230M Specification for Temperature-Electromotive Force (emf) Tables for Standardized Thermocouples

## 3. Summary of Test Method

3.1 Sixty millilitres (two ounces) of the sample are boiled under equilibrium conditions at atmospheric pressure in a 100 mL flask. The temperature of the liquid corrected for barometric pressure is the boiling point.

## 4. Apparatus (see Fig. 1)

4.1 *Flask*—A 100 mL round-bottom, short-neck, heat-resistant glass flask having a neck with a  $1/8$  standard-taper, female ground-glass joint and a 10 mm (0.4 in.) outside diameter side-entering tube, so located as to permit the end of the thermometer device to be directly centered in the flask approximately 6.5 mm (0.26 in.) from the bottom. The flask is shown in Fig. 2.

4.2 *Condenser*—The condenser shall be of the water-cooled, reflux, glass-tube type, having a condenser jacket 200 mm (7.9 in.) in length. The bottom end of the condenser shall have a  $1/8$  standard-taper, drip-tip, male ground-glass joint.

4.3 *Boiling Stones*—Three or four silicon carbide grains, grit No. 8 or other suitable inert chips, shall be used for each determination. For samples exhibiting heavy foam, more boiling chips may be added.

4.4 *Temperature Measuring Instrument (Environmentally Safe Thermometer or Thermocouple)*—An ASTM Partial Immersion Thermometer, having a range from  $-5^{\circ}\text{C}$  to  $300^{\circ}\text{C}$  ( $20^{\circ}\text{F}$  to  $580^{\circ}\text{F}$ ) and conforming to the requirements for Thermometer 2C or 2F, as prescribed in Specification E1, or some other suitable non-mercury containing temperature measuring device, such as a thermocouple, capable of operating in the same temperature range and having equal or better accuracy as summarized in Specification E230/E230M. See Section 10, Precision and Bias.

4.5 *Heat Source*—A suitable electric heating mantle shall be used, such that sufficient heat can be obtained to comply with the heating and refluxing rates specified in Section 7.

\*A Summary of Changes section appears at the end of this standard

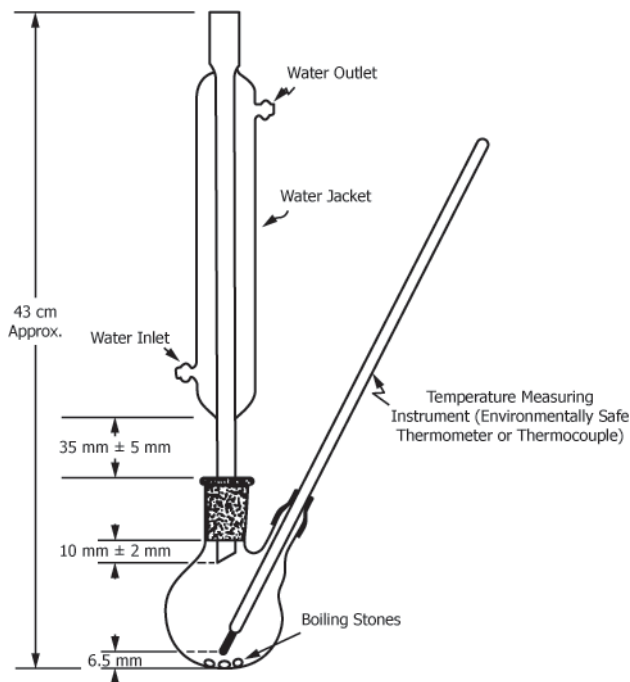
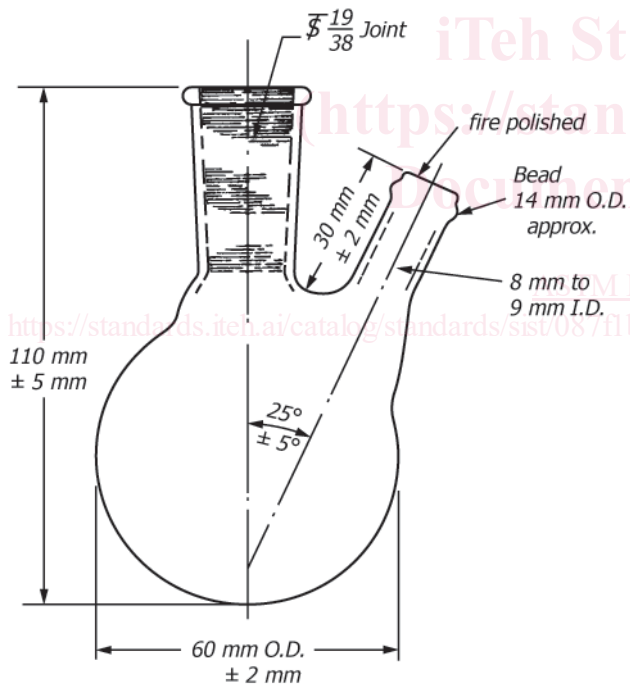

FIG. 1 Boiling Point Test Apparatus



100 mL Flask

FIG. 2 Short-Neck Flask, 100 mL

## 5. Sample

5.1 To obtain a sample of unused concentrated coolant for boiling point determination, the following procedure is suggested:

5.1.1 Allow material as received in the original container to come to room temperature 20 °C (68 °F) but not below 20 °C minimum).

5.1.2 Shake the container to mix any material that may have separated.

5.1.3 Immediately remove desired sample for test requirement.

5.2 To prepare a dilute solution of any mixture, thoroughly mix the sample, pipet the required volume into a calibrated volumetric flask, and add distilled water to bring the mixed contents of the flask to the proper volume while maintaining the calibration temperature.

5.3 The procedure for obtaining a representative test sample of a coolant solution that contains an antileak additive is found in Practice D1176.

## 6. Preparation of Apparatus

6.1 Use a calibrated temperature measuring instrument (thermometer or thermocouple).

6.2 Insert the calibrated temperature measuring instrument through the side tube until the tip of the bulb is approximately 6.5 mm (0.26 in.) from the bottom of the center of the flask. Make a seal around the temperature measuring instrument with a short piece of rubber tubing or other suitable material.

6.3 Place 60 mL (2 oz) of the sample to be tested, together with three or four silicon carbide grains, into the flask.

6.4 Attach the chemically cleaned condenser to the flask and mount the flask in an appropriate heating mantle. Support the glassware by a laboratory-type ring support and stand. The whole assembly is held in place by a clamp. Connect the cooling water inlet and outlet tubes to the condenser.

## 7. Procedure

7.1 When assembled as shown in Fig. 1, turn on the condenser water and apply heat by means of an electric heater at such a rate that the sample is brought to its boiling point within 15 min. Heat strongly until boiling is reached and then reduce heat input slowly until the required reflux rate is obtained. Adjust the rate of reflux over the next 10 min period to 1 to 2 drops of reflux per second. To obtain accurate results, it is important to carefully observe the specified reflux rate and maintain the proper reflux rate for 2 min before reading the temperature.

7.2 Record the observed temperature and the barometric pressure.

## 8. Calculation

8.1 *Temperature Measuring Instrument Inaccuracy*—Correct the observed temperature by applying the correction factor obtained in calibrating the thermometer or thermocouple for inaccuracy (6.1).

8.2 *Variation from Standard Barometric Pressure*—This correction shall be applied to the observed temperature after correction for inaccuracy of the thermometer. Use Table 1 to determine the barometric correction.