



Designation: C12 – 22a

Standard Practice for Installing Vitrified Clay Pipe Lines¹

This standard is issued under the fixed designation C12; the number immediately following the designation indicates the year of original adoption or, in the case of revision, the year of last revision. A number in parentheses indicates the year of last reappraisal. A superscript epsilon (ϵ) indicates an editorial change since the last revision or reappraisal.

This standard has been approved for use by agencies of the U.S. Department of Defense.

1. Scope

1.1 This practice covers the proper methods of installing vitrified clay pipe lines by open trench construction methods in order to fully utilize the structural properties of such pipe.

1.2 The values stated in inch-pound units are to be regarded as standard. The values given in parentheses are mathematical conversions to SI units that are provided for information only and are not considered standard.

1.3 *This standard does not purport to address all of the safety concerns, if any, associated with its use. It is the responsibility of the user of this standard to establish appropriate safety, health, and environmental practices and determine the applicability of regulatory limitations prior to use.*

1.4 *This international standard was developed in accordance with internationally recognized principles on standardization established in the Decision on Principles for the Development of International Standards, Guides and Recommendations issued by the World Trade Organization Technical Barriers to Trade (TBT) Committee.*

2. Referenced Documents

2.1 *ASTM Standards:*²

- C301 Test Methods for Vitrified Clay Pipe
- C425 Specification for Compression Joints for Vitrified Clay Pipe and Fittings
- C700 Specification for Vitrified Clay Pipe, Extra Strength, Standard Strength, and Perforated
- C828 Test Method for Low-Pressure Air Test of Vitrified Clay Pipe Lines
- C896 Terminology Relating to Clay Products
- C923/C923M Specification for Resilient Connectors Between Reinforced Concrete Manhole Structures, Pipes, and Laterals

¹ This practice is under the jurisdiction of ASTM Committee C04 on Vitrified Clay Pipe and is the direct responsibility of Subcommittee C04.20 on Methods of Test and Specifications.

Current edition approved Sept. 1, 2022. Published September 2022. Originally approved in 1915. Last previous edition approved in 2022 as C12 – 22. DOI: 10.1520/C0012-22A.

² For referenced ASTM standards, visit the ASTM website, www.astm.org, or contact ASTM Customer Service at service@astm.org. For *Annual Book of ASTM Standards* volume information, refer to the standard's Document Summary page on the ASTM website.

- C1091 Test Method for Hydrostatic Infiltration Testing of Vitrified Clay Pipe Lines
- D1586/D1586M Test Method for Standard Penetration Test (SPT) and Split-Barrel Sampling of Soils
- D2487 Practice for Classification of Soils for Engineering Purposes (Unified Soil Classification System)
- D2488 Practice for Description and Identification of Soils (Visual-Manual Procedures)
- D4832 Test Method for Preparation and Testing of Controlled Low Strength Material (CLSM) Test Cylinders
- D5821 Test Method for Determining the Percentage of Fractured Particles in Coarse Aggregate
- D6024/D6024M Test Method for Ball Drop on Controlled Low Strength Material (CLSM) to Determine Suitability for Load Application
- D6103/D6103M Test Method for Flow Consistency of Controlled Low Strength Material (CLSM)

3. Terminology

3.1 *General*—Terminology C896 can be used for clarification of terminology in this specification.

3.2 See Fig. 1.

DESIGN CONSIDERATIONS

4. Supporting Strength

4.1 The field supporting strength of vitrified clay pipe is materially affected by the methods of installation. The field supporting strength of a pipe is defined as its capacity to support dead and live loads under actual field conditions. It is dependent upon two factors: (1) the inherent strength of the pipe and (2) the bedding of the pipe.

4.2 The minimum bearing strength requirement in accordance with Specification C700, as determined by the 3-edge-bearing test of Test Methods C301, is a measure of the inherent strength of the pipe.

4.3 The tests used to measure bearing strength determine relative pipe strengths but do not represent actual field conditions. Therefore, an adjustment called a load factor is introduced to convert minimum bearing strength to field supporting strength. The magnitude of the load factor depends on how the pipe is bedded. The relationship is:

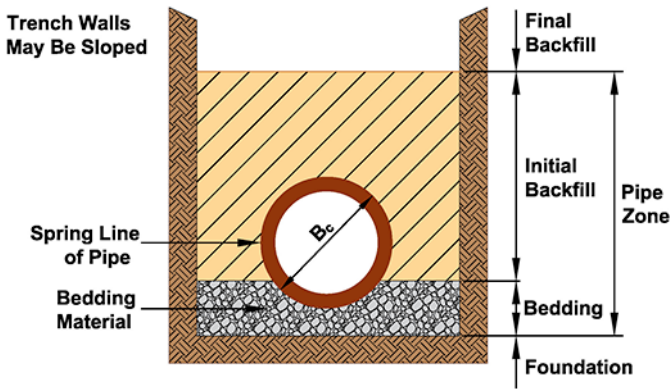

Trench Cross Section (Class C shown)

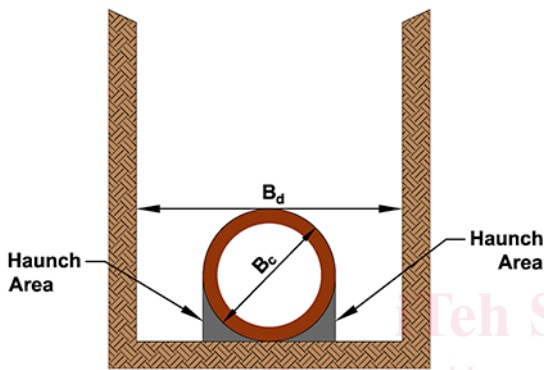

B_c = the outside diameter of the pipe barrel.
 B_d = the design trench width measured at the horizontal plane at the top of the pipe barrel.

FIG. 1 Terminology

Field supporting strength = minimum bearing strength \times load factor

4.4 A factor of safety >1.0 and ≤ 1.5 shall be applied to the field supporting strength to calculate a safe supporting strength. The relationship is:

$$\text{Safe supporting strength} = \frac{\text{Field supporting strength}}{\text{Factor of safety}}$$

5. External Loads

5.1 The external loads on installed vitrified clay pipe are of two general types: (1) dead loads and (2) live loads.

5.2 For pipes installed in trenches at a given depth, the dead load increases as the trench width, measured at the top of the pipe, increases. Pipe failure may result if the design trench width is exceeded. If the trench width exceeds the design width, a higher class of bedding, stronger pipe, or both, must be investigated.

5.3 Live loads that act at the ground surface are partially transmitted to the pipe. Live loads may be produced by wheel loading, construction equipment or by compactive effort. Compaction of embedment and backfill materials, beside and above the sewer pipe, produces a temporary live load on the pipe. The magnitude of the live load from compactive effort varies with soil type, degree of saturation, degree of compaction and depth of cover over the pipe. Care must be used in

selection of compaction methods so that the combined dead load and live load does not exceed the field supporting strength of the pipe, or cause a change in its line or grade.

NOTE 1—For generally accepted criteria and methods for determining loads and supporting strengths, see *Gravity Sanitary Sewer Design and Construction, Water Pollution Control Federation Manual of Practice No. FD-5, American Society of Civil Engineers—Manuals and Report on Engineering Practice—No. 60.*³

6. Bedding and Encasement

6.1 Classes of bedding and encasements for pipe in trenches are defined herein. The load factors indicated are for conversion of minimum bearing strength to field supporting strength.

6.1.1 The soil groups used in each bedding class are defined in Table 1.

6.1.2 The gradation for Class I and Class II soil for Class C bedding (Fig. 3) shall have a maximum particle size of 1 in. (25 mm).

6.1.3 The gradation for Class I and Class II bedding material for Class B (Fig. 4), Crushed Stone Encasement (Fig. 5), and CLSM installation (Fig. 6) shall be as follows:

- 100 % passing a 1 in. (25 mm) sieve
- 40-60 % passing a 3/4 in. (19 mm) sieve
- 0-25 % passing a 3/8 in. (9.5 mm) sieve

6.1.4 For Class I, all particle faces shall be fractured.

6.1.5 Class II soils shall have a minimum of one fractured face. For Class B (Fig. 4), Crushed Stone Encasement (Fig. 5), and CLSM installations (Fig. 6) where high, or changing water tables, or both, are present; Class II material shall have a minimum percentage by particle count of one fractured face-100 %, two fractured faces-85 %, and three fractured faces-65 % in accordance with Test Method D5821.

6.1.6 Class I material is considered to be more stable and provide better support than Class II material that have some rounded edges.

6.1.7 All bedding material shall be shovel-sliced so the material fills and supports the haunch area and encases the pipe to the limits shown in the trench diagrams.

6.2 Class D (Fig. 2):

6.2.1 The pipe shall be placed on a foundation with bell holes provided (Fig. 7).

6.2.2 The initial backfill shall be either Class I, II, III, or IV having a maximum particle size of 1 in. (25 mm).

6.2.3 The load factor for Class D bedding is 1.1.

6.3 Class C (Fig. 3):

6.3.1 The pipe shall be bedded in Class I or Class II soil. Refer to 6.1.2 and Table 2 for requirements. Sand is suitable as a bedding material in a total sand environment, but may be unsuitable where high and rapidly changing water tables are present in the pipe zone. Sand may also be undesirable in a trench cut by blasting or in trenches through clay type soil. Regardless of the trench condition or bedding class, the maximum load factor for sand bedding is 1.5. The bedding shall have a minimum thickness beneath the pipe of 4 in. (100 mm) or one sixth of the outside diameter of the pipe, whichever

³ Available from American Society of Civil Engineers (ASCE), 1801 Alexander Bell Dr., Reston, VA 20191, <http://www.asce.org>.

TABLE 1 Uniform Soil Groups for Pipe Installation

NOTE 1—Soil Classification descriptions and symbols are in accordance with Practice D2487 and Practice D2488.

NOTE 2—For Class I, all particle faces shall be fractured.

NOTE 3—Materials such as broken coral, shells, slag, and recycled concrete (with less than 12 % passing a #200 sieve) should be treated as Class II soils.

NOTE 4—Class V soil is not suitable for use as a bedding or initial backfill material.

Class I	crushed rock 100 % passing 1-1/2 in. (38 mm) sieve, <= 15 % passing #4 sieve, <= 25 % passing 3/8 in. (9.5 mm) sieve, <= 12 % passing #200 sieve	
Class II	clean, coarse grained soils or any soil beginning with one of these symbols (can contain fines up to 12 %) uniform fine sands (SP) with more than 50 % passing a #100 sieve should be treated as Class III material	GW, GP, SW, SP
Class III	coarse grained soils with fines or any soil beginning with one of these symbols sandy or gravelly fine grained soils or any soil beginning with one of these symbols with >= 30 % retained on #200 sieve	GM, GC, SM, SC ML, CL
Class IV	fine-grained soils or any soil beginning with one of these symbols with <30 % retained on #200 sieve	ML, CL
Class V	fine-grained soils, organic soils high compressibility silts and clays, organic soil	MH, CH, OL, OH, Pt

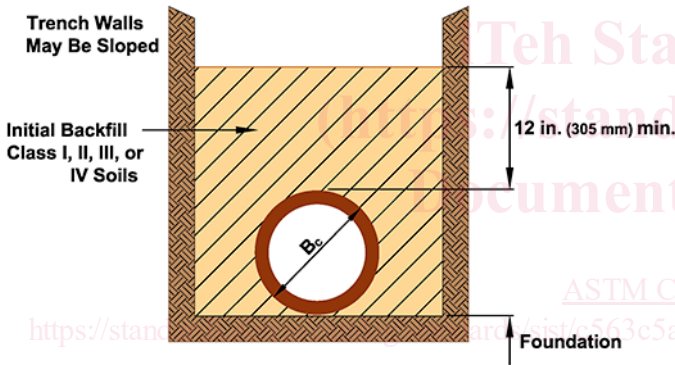

Class D Bedding - Load Factor = 1.1
FIG. 2 Class D

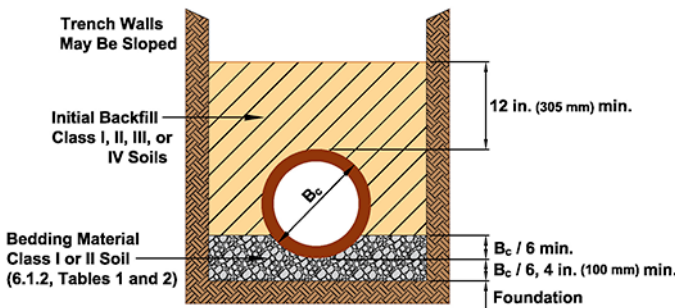

Class C Bedding - Load Factor = 1.5
FIG. 3 Class C

is greater, and shall extend up the haunches of the pipe one sixth of the outside diameter of the pipe.

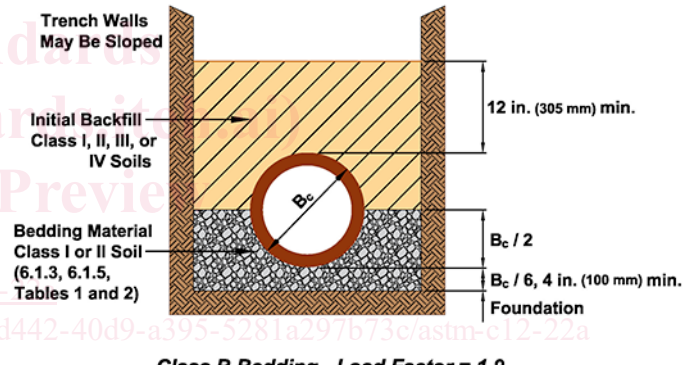

Class B Bedding - Load Factor = 1.9
FIG. 4 Class B

6.3.2 The initial backfill shall be either Class I, II, III, or IV having maximum particle size of 1-1/2 in. (38 mm) (see Table 2).

6.3.3 The load factor for Class C bedding is 1.5.

6.4 Class B (Fig. 4):

6.4.1 The pipe shall be bedded in Class I or Class II soil. Refer to 6.1.3, 6.1.5, and Table 2 for requirements. The bedding shall have a minimum thickness beneath the pipe of 4 in. (100 mm) or one sixth of the outside diameter of the pipe, whichever is greater, and shall extend up the haunches of the pipe to the springline.

6.4.2 The initial backfill shall be either Class I, II, III, or IV having a maximum particle size of 1-1/2 in. (38 mm).

6.4.3 The load factor for Class B bedding is 1.9.

6.5 Crushed Stone Encasement (Fig. 5):

6.5.1 The pipe shall be bedded in Class I or Class II soil. Refer to 6.1.3, 6.1.5, and Table 2 for requirements. The

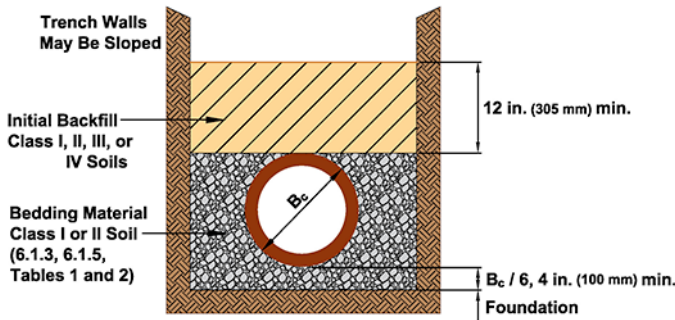

Crushed Stone Encasement Bedding - Load Factor = 2.2

FIG. 5 Crushed Stone Encasement

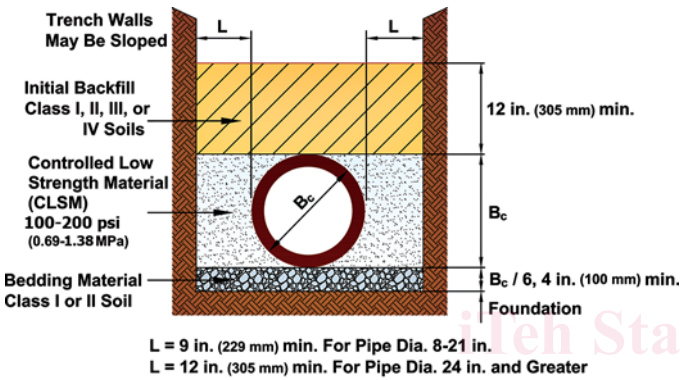

Controlled Low Strength Material (CLSM) Bedding - Load Factor = 2.8

This type of construction requires the fill to extend from the pipe to the trench wall, not to extend above the top of the pipe or below the bottom of the pipe. Where native soils are expansive, further investigation may be necessary.

FIG. 6 Controlled Low Strength Material (CLSM)

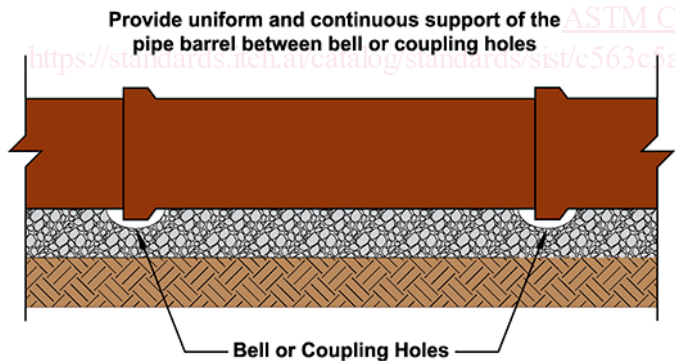

FIG. 7 Uniform Pipe Support

bedding shall have a minimum thickness beneath the pipe of 4 in. (100 mm) or one sixth of the outside diameter of the pipe, whichever is greater, and shall extend upward to a horizontal plane at the top of the pipe barrel. Material shall be carefully placed into the pipe haunches.

6.5.2 Sufficient material shall be placed so that the bedding extends to a horizontal plane at the top of the pipe barrel following removal of any trench sheeting or boxes.

6.5.3 The initial backfill shall be either Class I, II, III, or IV having a maximum particle size of 1-1/2 in. (38 mm).

6.5.4 The load factor for crushed stone encasement is 2.2.

6.6 **Controlled Low Strength Material (Fig. 6)**—Controlled low strength material (CLSM) is used as an effective material for the bedding of vitrified clay pipe.

6.6.1 The pipe shall be bedded on Class I or Class II soil. Refer to 6.1.3, 6.1.5, and Table 2 for requirements. The bedding shall have a minimum thickness beneath the pipe of 4 in. (100 mm) or one sixth of the outside diameter of the pipe, whichever is greater.

6.6.2 For pipe diameters 8 to 21 in. (205 to 535 mm), CLSM shall extend a minimum of 9 in. (230 mm) on each side of the pipe barrel. For pipe diameters 24 in. (610 mm) and larger, CLSM shall extend a minimum of 12 in. (305 mm) on each side of the pipe barrel (Fig. 6).

6.6.3 When placed, CLSM shall have a measured flowability of 8 to 12 in. (205 to 305 mm) spread diameter as determined by Test Method D6103/D6103M.

6.6.4 28-day compressive strength shall be 100 to 200 psi (0.69 to 1.38 MPa) as determined by Test Method D4832.

6.6.5 CLSM shall be directed to the top of the pipe to flow down equally on both sides to prevent misalignment. Place CLSM to the top of the pipe barrel.

6.6.6 The initial backfill shall be either Class I, II, III, or IV having a maximum particle size of 1-1/2 in. (38 mm).

6.6.7 Initial backfill shall only commence after a Ball Drop test is conducted and the measured diameter of the indentation left by the ball is 3 in. or less as determined by Test Method D6024/D6024M.

6.6.8 The load factor for controlled low strength material is 2.8.

6.7 Concrete Cradle (Fig. 8):

6.7.1 The pipe shall be bedded in a cradle of reinforced concrete having a thickness under the barrel of at least 6 in. (150 mm) or one fourth of the outside diameter of the pipe, whichever is greater, and extending up the haunches to a height of at least one half the outside diameter of the pipe. The cradle width shall be at least equal to the outside diameter of the pipe plus 4 in. (100 mm) on each side or one and one fourth times the outside diameter of the pipe, whichever is greater. If the trench width is greater than either of these dimensions, concrete may be placed to full trench width.

6.7.2 The initial backfill shall be either Class I, II, III, or IV having a maximum particle size of 1-1/2 in. (38 mm).

6.7.3 The load factor for Class A concrete cradle bedding is 3.4 for reinforced concrete with $p = 0.4\%$, where p is the percentage of the area of transverse steel to the area of concrete at the bottom of the pipe barrel as shown in Fig. 8.

6.8 Concrete Encasement:

6.8.1 There are specific sites where concrete encasement may be desirable. Concrete encasement shall completely surround the pipe and shall have a minimum thickness, at any point, of one fourth of the outside diameter of the pipe or 4 in. (100 mm), whichever is greater.

6.8.2 The encasement shall be designed by the engineer to suit the specific use.

6.9 Construction joints shall be installed in concrete cradle or concrete encasement construction. These joints shall be aligned with the face of the socket.

TABLE 2 Allowable Bedding Material and Initial Backfill Per Bedding Class

Bedding Class	Allowable Bedding Material			Allowable Initial Backfill	
	Class Table 1	Gradation	Maximum Particle Size	Class Table 1	Maximum Particle Size
Class D	N/A	N/A	N/A	I, II, III, or IV	1 in. (25 mm)
Class C	I or II	100 % passing a 1 in. (25 mm) sieve	1 in. (25 mm)	I, II, III, or IV	1-1/2 in. (38 mm)
Class B	I or II	40-60 % passing a 3/4 in. (19 mm) sieve 0-25 % passing a 3/8 in. (9.5 mm) sieve	1 in. (25 mm)	I, II, III, or IV	1-1/2 in. (38 mm)
Crushed Stone Encasement	I or II	100 % passing a 1 in. (25 mm) sieve 40-60% passing a 3/4 in. (19 mm) sieve 0-25% passing a 3/8 in. (9.5 mm) sieve	1 in. (25 mm)	I, II, III, IV, or CLSM	1-1/2 in. (38 mm)
CLSM		100 % passing a 1 in. (25 mm) sieve 40-60 % passing a 3/4 in. (19 mm) sieve 0-25 % passing a 3/8 in. (9.5 mm) sieve			
Concrete Cradle	N/A	N/A	N/A	I, II, III, or IV	1-1/2 in. (38 mm)

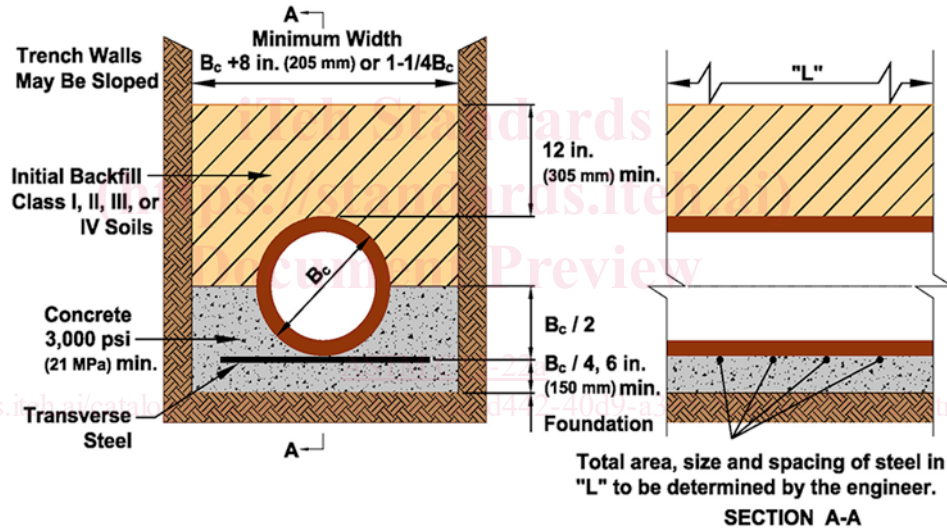

Concrete Cradle Bedding - Load Factor = 3.4 Reinforced Concrete $p = 0.4\%$

Minimum width of concrete cradle: $B_c + 8$ in. (205 mm) or $1-1/4 B_c$.

p is the ratio of the area of steel to the area of concrete. (It is recommended that wire mesh reinforcement or uniformly distributed small diameter rebar be used in all concrete design.)

FIG. 8 Concrete Cradle

CONSTRUCTION TECHNIQUES

7. Trench Excavation

7.1 Trenches shall be excavated to a width that provides working space required to place Class I or Class II material in the pipe haunches. Trench walls shall not be undercut.

7.2 The trench walls can be sloped to reduce trench wall failure. This sloping will not increase the load on the pipe provided the measured trench width at top of pipe does not exceed the design trench width.

7.3 Trenches, other than for Class D bedding, shall be excavated to provide space for the pipe bedding.

7.4 Sheet, shore, and brace trenches, as necessary, to prevent caving or sliding of trench walls, to provide protection for workmen and the pipe, and to protect adjacent structures and facilities.

7.5 Sheeting shall not be removed below the top of the pipe if the resulting slope of native soil increases the trench width to such an extent that the load on the pipe exceeds the safe field supporting strength of the pipe and bedding system.