



Designation: F2267 – 22

Standard Test Method for Measuring Load-Induced Subsidence of Intervertebral Body Fusion Device Under Static Axial Compression¹

This standard is issued under the fixed designation F2267; the number immediately following the designation indicates the year of original adoption or, in the case of revision, the year of last revision. A number in parentheses indicates the year of last reapproval. A superscript epsilon (ϵ) indicates an editorial change since the last revision or reapproval.

1. Scope

1.1 This test method specifies the materials and methods for the axial compressive subsidence testing of non-biologic intervertebral body fusion devices, spinal implants designed to promote arthrodesis at a given spinal motion segment.

1.2 This test method is intended to provide a basis for the mechanical comparison among past, present, and future non-biologic intervertebral body fusion devices. This test method is intended to enable the user to mechanically compare intervertebral body fusion devices and does not purport to provide performance standards for intervertebral body fusion devices.

1.3 This test method describes a static test method by specifying a load type and a specific method of applying this load. This test method is designed to allow for the comparative evaluation of intervertebral body fusion devices.

1.4 Guidelines are established for measuring test block deformation and determining the subsidence of intervertebral body fusion devices.

1.5 Since some intervertebral body fusion devices require the use of additional implants for stabilization, the testing of these types of implants may not be in accordance with the manufacturer's recommended usage.

1.6 *Units*—The values stated in SI units are to be regarded as the standard with the exception of angular measurements, which may be reported in terms of either degrees or radians.

1.7 The use of this standard may involve the operation of potentially hazardous equipment. *This standard does not purport to address all of the safety concerns, if any, associated with its use. It is the responsibility of the user of this standard to establish appropriate safety, health, and environmental practices and determine the applicability of regulatory limitations prior to use.*

1.8 *This international standard was developed in accordance with internationally recognized principles on standard-*

ization established in the Decision on Principles for the Development of International Standards, Guides and Recommendations issued by the World Trade Organization Technical Barriers to Trade (TBT) Committee.

2. Referenced Documents

2.1 *ASTM Standards:*²

E4 Practices for Force Calibration and Verification of Testing Machines

E177 Practice for Use of the Terms Precision and Bias in ASTM Test Methods

E691 Practice for Conducting an Interlaboratory Study to Determine the Precision of a Test Method

F1582 Terminology Relating to Spinal Implants

F1839 Specification for Rigid Polyurethane Foam for Use as a Standard Material for Testing Orthopaedic Devices and Instruments

F2077 Test Methods for Intervertebral Body Fusion Devices

3. Terminology

3.1 All subsidence testing terminology is consistent with the referenced standards above, unless otherwise stated.

3.2 *Definitions:*

3.2.1 *coordinate system/axes*—three orthogonal axes are defined by Terminology **F1582** as seen in Fig. 4. The center of the coordinate system is located at the geometric center of the intervertebral body fusion device assembly. The *X*-axis is along the longitudinal axis of the implant, with positive *X* in the anterior direction, *Y* is lateral, and *Z* is cephalic.

3.2.2 *ideal insertion location*—the implant location with respect to the simulated inferior and superior vertebral bodies (polyurethane) dictated by the type, design, and manufacturer's surgical installation instructions.

3.2.3 *intended method of application*—intervertebral body fusion devices may contain different types of stabilizing features such as threads, spikes, and knurled surfaces. Each

¹ This test method is under the jurisdiction of ASTM Committee **F04** on Medical and Surgical Materials and Devices and is the direct responsibility of Subcommittee **F04.25** on Spinal Devices.

Current edition approved Sept. 1, 2022. Published September 2022. Originally approved in 2003. Last previous edition approved in 2018 as F2267 – 04 (2018). DOI: 10.1520/F2267-22.

² For referenced ASTM standards, visit the ASTM website, www.astm.org, or contact ASTM Customer Service at service@astm.org. For *Annual Book of ASTM Standards* volume information, refer to the standard's Document Summary page on the ASTM website.

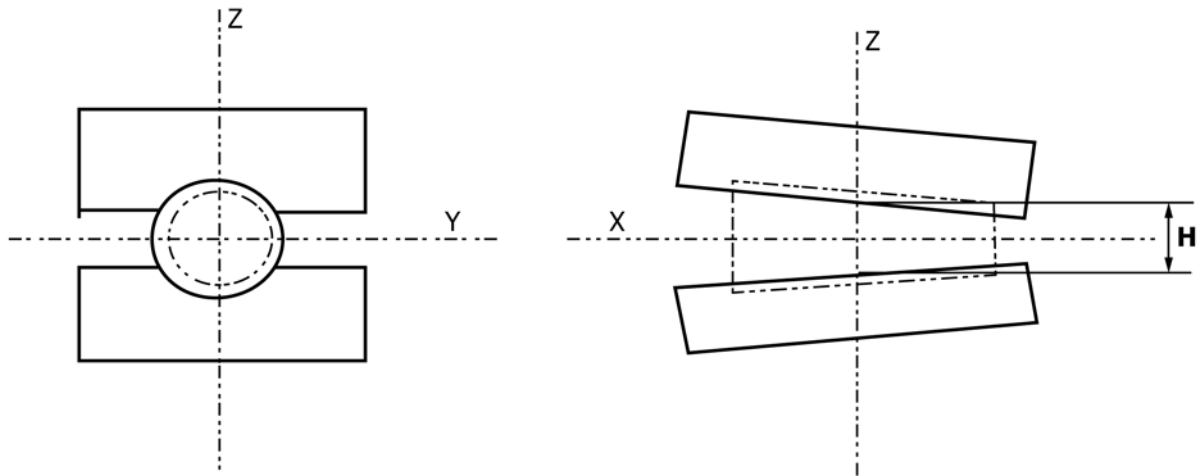

FIG. 1 Intradiscal Height Diagram

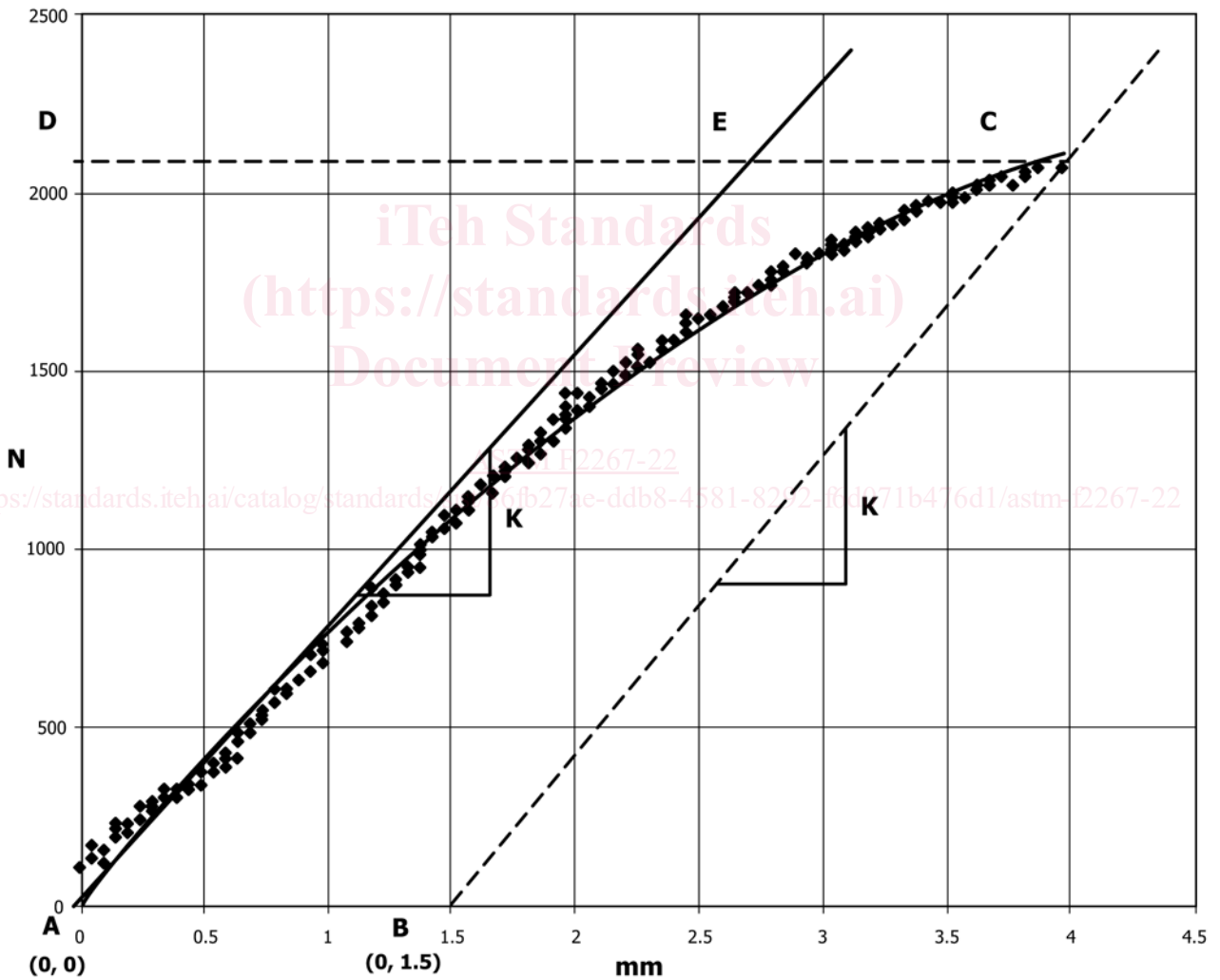

FIG. 2 Typical Load-Displacement Curve with 1.5 mm (Thoracic Device) Offset for Polyurethane Foam Test Blocks

type of feature has an intended method of application or attachment to the spine.

3.2.4 *intended spinal location*—the anatomic region of the spine intended for the intervertebral body fusion device.

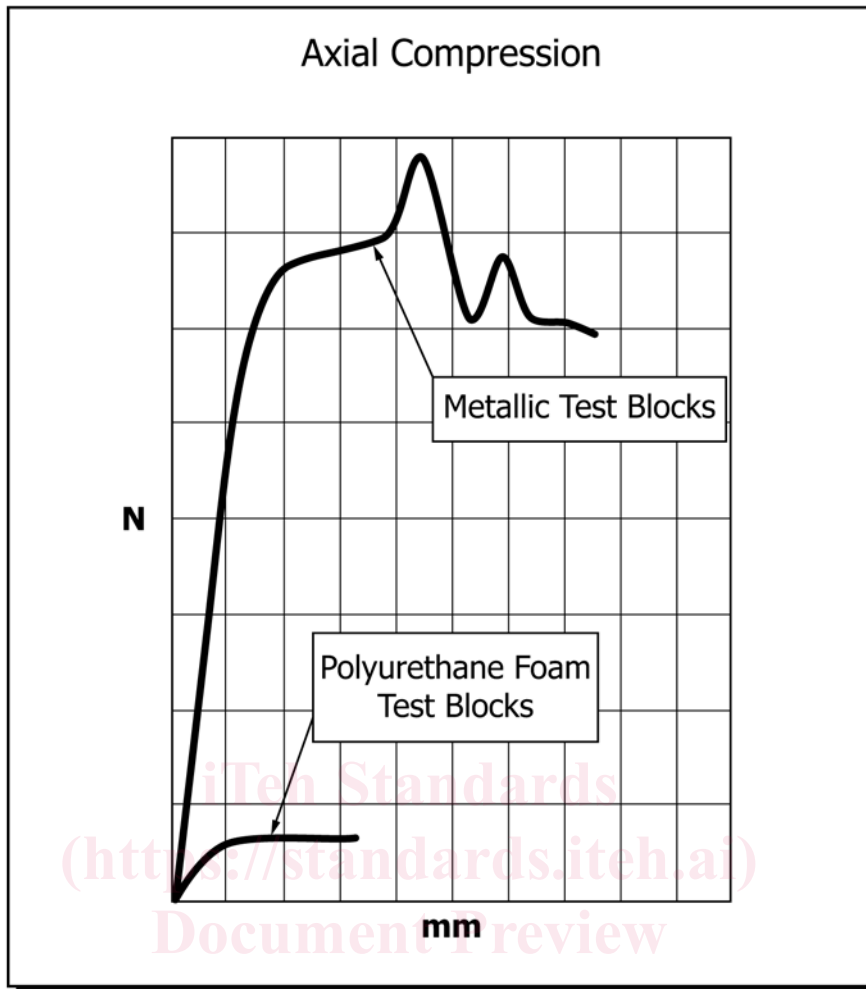

FIG. 3 Typical Load-Displacement Plot Comparison for Test Specimens in Metallic and Polyurethane Test Blocks

Intervertebral body fusion devices may be designed and developed for specific regions of the spine such as the lumbar, thoracic, and cervical spine. Also, there potentially exist different anatomical surgical approaches, which will result in different implant orientation at different levels of the spine.

3.2.5 *intervertebral subsidence*—the process of a vertebral body cavitating or sinking around an implanted intervertebral body fusion device resulting in the loss of intradiscal height.

3.2.6 *intradiscal height*—the straight-line distance along the Z-axis between the unaltered simulated vertebral bodies. See Fig. 1.

3.2.7 *load point*—the point through which the resultant force on the intervertebral device passes (that is, the geometric center of the superior fixture’s sphere) (Fig. 4).

3.2.8 *offset displacement*—offset on the displacement axis equal to 1 mm for cervical disc devices, 1.5 mm for thoracic devices, and 2 mm for lumbar devices (see distance AB in Fig. 2)

3.2.9 *simulated vertebral bodies*—the component of the test apparatus for mounting the intervertebral body fusion device.

3.2.10 *stiffness*, (N/mm)—the slope of the initial linear portion of the load-displacement curve (see the slope of line AE in Fig. 2).

3.2.11 *test block height*—the linear distance along the Z-axis from the top surface of the superior simulated vertebral body to the bottom surface of the inferior simulated vertebral body with the intervertebral body fusion device in position. The block heights shall be 70 mm, 60 mm, and 40 mm for lumbar, thoracic, and cervical intervertebral disc devices respectively. See Fig. 4.

3.2.12 *yield load*—the applied load, F , transmitted by the pushrod (assumed equal to force component parallel to and indicated by load cell), required to produce a permanent deformation equal to the offset displacement found by plotting line BC with stiffness, K , originating at point B (see Point D in Fig. 2).

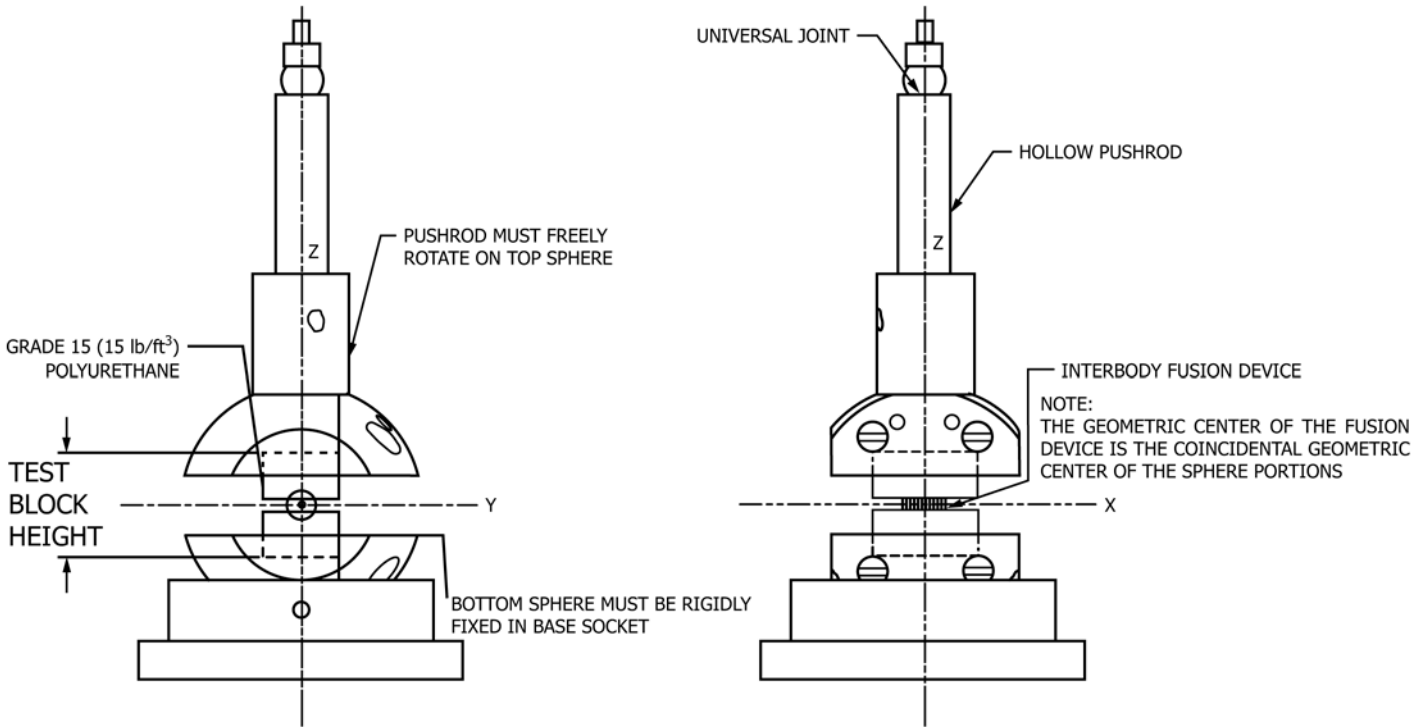

FIG. 4 Subsidence Test Fixture

4. Summary of Test Method

4.1 To measure load-induced subsidence, a test method is proposed for the axial compression of intervertebral body fusion devices specific to the lumbar, thoracic, and cervical spine.

4.2 The axial compressive subsidence testing of the intervertebral body fusion device will be conducted in a simulated motion segment via a gap between two polyurethane foam blocks.

4.3 Grade 15 foam shall be employed conforming to Specification F1839.

5. Significance and Use

5.1 Intervertebral body fusion devices are generally simple geometric-shaped devices, which are often porous or hollow in nature. Their function is to support the anterior column of the spine to facilitate arthrodesis of the motion segment.

5.2 This test method is designed to quantify the subsidence characteristics of different designs of intervertebral body fusion devices since this is a potential clinical failure mode. These tests are conducted *in vitro* in order to simplify the comparison of simulated vertebral body subsidence induced by the intervertebral body fusion devices.

5.3 The static axial compressive loads that will be applied to the intervertebral body fusion devices and test blocks will differ from the complex loading seen *in vivo*, and therefore, the results from this test method may not be used to directly predict *in vivo* performance. The results, however, can be used to compare the varying degrees of subsidence between different intervertebral body fusion device designs for a given density of simulated bone.

5.4 The location within the simulated vertebral bodies and position of the intervertebral body fusion device with respect to the loading axis will be dependent upon the design and manufacturer's recommendation for implant placement.

6. Apparatus

6.1 Test machines will conform to the requirements of Practices E4.

6.2 The intradiscal height, H (Fig. 1), shall be determined from vertebral body and disc morphometric data at the intended level of application. Suggested heights are as follows: 10 mm for the lumbar spine, 6 mm for the thoracic spine, and 4 mm for the cervical spine. The user of this test method should select the intradiscal height that is appropriate for the device being tested.

6.3 *Axial Compressive Testing Apparatus*—An example axial compressive test fixture can be referenced in Figs. 4 and 5. Two pieces of polyurethane foam or rigid metal are rigidly mounted inside the test fixture. The actuator of the testing machine is connected to the pushrod by a minimal friction ball-and-socket joint or universal joint (that is, unconstrained in bending). The pushrod is connected to the superior fixture by a minimal friction sphere joint (that is, unconstrained in bending and torsion). The inferior sphere portion firmly holds the inferior polyurethane block and is rigidly fixed within the base socket so that no rotation occurs. The hollow pushrod and superior sphere should be of minimal weight so as to be considered a “two force” member. It thus applies to the intervertebral device a resultant force directed along the pushrod's axes and located at the center of the superior fixture's sphere joint (the geometric center of the device being tested). The polyurethane blocks are to have surfaces that mate