



Designation: **C506—22 C506 – 22a**

Standard Specification for Reinforced Concrete Arch Culvert, Storm Drain, and Sewer Pipe¹

This standard is issued under the fixed designation C506; the number immediately following the designation indicates the year of original adoption or, in the case of revision, the year of last revision. A number in parentheses indicates the year of last reappraisal. A superscript epsilon (ϵ) indicates an editorial change since the last revision or reappraisal.

This standard has been approved for use by agencies of the U.S. Department of Defense.

1. Scope*

1.1 This specification covers reinforced arch-shaped concrete pipe to be used for the conveyance of sewage, industrial wastes, storm water, and for the construction of culverts.

1.2 This specification is the inch-pound companion to C506M; therefore, no SI equivalents are presented in the specification. Reinforced concrete pipe that conform to the requirements of C506M are acceptable under this Specification C506 unless prohibited by the owner.

NOTE 1—This specification is a manufacturing and purchase specification only, and does not include requirements for bedding, backfill, or the relationship between field load condition and the strength classification of pipe. However, experience has shown that the successful performance of this product depends upon the proper selection of the class of pipe, type of bedding and backfill, and care that the installation conforms to the construction specifications. The owner of the reinforced concrete pipe specified herein is cautioned that he must correlate the field requirements with the class of pipe specified and provide inspection at the construction site.

1.3 *This international standard was developed in accordance with internationally recognized principles on standardization established in the Decision on Principles for the Development of International Standards, Guides and Recommendations issued by the World Trade Organization Technical Barriers to Trade (TBT) Committee.*

2. Referenced Documents

2.1 ASTM Standards:²

- A36/A36M Specification for Carbon Structural Steel
- A615/A615M Specification for Deformed and Plain Carbon-Steel Bars for Concrete Reinforcement
- A706/A706M Specification for Deformed and Plain Low-Alloy Steel Bars for Concrete Reinforcement
- A1064/A1064M Specification for Carbon-Steel Wire and Welded Wire Reinforcement, Plain and Deformed, for Concrete
- C33/C33M Specification for Concrete Aggregates
- C150/C150M Specification for Portland Cement
- C260/C260M Specification for Air-Entraining Admixtures for Concrete
- C309 Specification for Liquid Membrane-Forming Compounds for Curing Concrete
- C494/C494M Specification for Chemical Admixtures for Concrete
- C497 Test Methods for Concrete Pipe, Concrete Box Sections, Manhole Sections, or Tile

¹ This specification is under the jurisdiction of ASTM Committee C13 on Concrete Pipe and is the direct responsibility of Subcommittee C13.02 on Reinforced Sewer and Culvert Pipe.

Current edition approved Sept. 1, 2022/Sept. 15, 2022. Published September 2022. Originally approved in 1963. Last previous edition approved in 2020/2022 as C506—20/C506 – 22.¹ DOI: 10.1520/C0506-22; 10.1520/C0506-22A.

² For referenced ASTM standards, visit the ASTM website, www.astm.org, or contact ASTM Customer Service at service@astm.org. For *Annual Book of ASTM Standards* volume information, refer to the standard's Document Summary page on the ASTM website.

***A Summary of Changes section appears at the end of this standard**

- C595/C595M Specification for Blended Hydraulic Cements
- C618 Specification for Coal Fly Ash and Raw or Calcined Natural Pozzolan for Use in Concrete
- C822 Terminology Relating to Concrete Pipe and Related Products
- C989/C989M Specification for Slag Cement for Use in Concrete and Mortars
- C990 Specification for Joints for Concrete Pipe, Manholes, and Precast Box Sections Using Preformed Flexible Joint Sealants
- C1017/C1017M Specification for Chemical Admixtures for Use in Producing Flowing Concrete (Withdrawn 2022)³
- C1116/C1116M Specification for Fiber-Reinforced Concrete
- C1602/C1602M Specification for Mixing Water Used in the Production of Hydraulic Cement Concrete
- C1896 Specification for Joints for Concrete Arch Pipe Using Profile Rubber Gaskets

3. Terminology

3.1 Definitions—For definitions of terms relating to concrete pipe, see Terminology C822.

4. Classification

4.1 Pipe manufactured according to this specification shall be of three classes identified as Class A-II, A-III, and A-IV. The strength requirements are prescribed in Table 1.

TABLE 1 Strength Requirements for Reinforced Concrete Pipe^A

Approximate Equivalent Round Size, in.	T, in.	Minimum Rise, in.	Minimum Span, in.	Double Line Reinforcement ^C															Single Line Reinforcement				
				f'c, ^B ksi			Continuous Basic Reinforcement = A _s ^D						Additional Reinforcement = A _s ^D										
				Class			Inner Cage			Outer Cage			"U" (Inner Cage)			"V" (Outer Cage)							
				A-II	A-III	A-IV	A-II	A-III	A-IV	A-II	A-III	A-IV	Dimension, in.	A-II	A-III	A-IV	Dimension, in.	A-II	A-III	A-IV			
15	2¼	11	18	4	4	4	0.08	0.12	0.17			
18	2½	13½	22	4	4	4	0.11	0.14	0.26			
21	2¾	15½	26	4	4	4	0.12	0.17	0.29			
24	3	18	28½	4	4	4	0.16	0.21	0.32			
30	3½	22½	36¼	4	4	4	0.09	0.12	0.18	0.07	0.09	0.14	26	0.09	0.12	0.18	29	0.07	0.09	0.12	0.18	0.24	0.36
36	4	26¾	43¾	4	4	4	0.11	0.15	0.21	0.09	0.12	0.17	30	0.11	0.15	0.21	34	0.09	0.12	0.16	0.21	0.30	0.44
42	4½	31½	51½	4	4	4	0.12	0.18	0.27	0.10	0.14	0.21	34	0.12	0.18	0.27	39	0.10	0.14	0.21	0.26	0.36	0.54
48	5	36	58½	4	4	...	0.15	0.21	...	0.12	0.17	...	42	0.15	0.21	...	43	0.12	0.17	...	0.30	0.44	...
54	5½	40	65	4	4	...	0.18	0.24	...	0.14	0.19	...	48	0.18	0.24	...	49	0.14	0.19	...	0.36	0.48	...
60	6	45	73	4	4	...	0.21	0.27	...	0.17	0.21	...	52	0.21	0.27	...	55	0.17	0.21	...	0.42	0.56	...
72	7	54	88	4	5	...	0.26	0.36	...	0.20	0.27	...	60	0.26	0.36	...	67	0.20	0.27	...	0.52	0.72	...
84	8	62	102	4	5	...	0.32	0.44	...	0.24	0.34	...	68	0.32	0.44	...	77	0.24	0.34	...	0.64	0.88	...
90	8½	72	115
96	9	77½	122
108	10	87½	138
120	11	96¾	154
132	10	106½	168¾

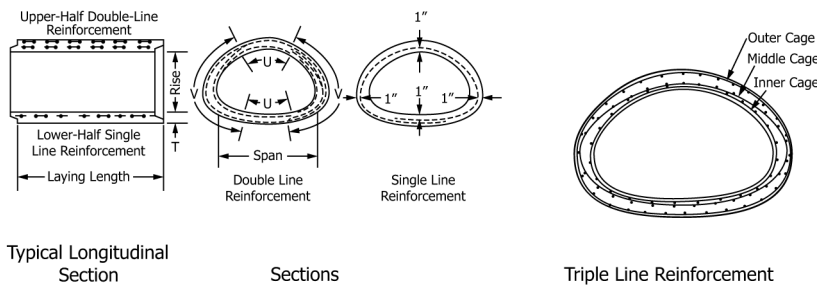

Class	0.01-in. Crack	Ultimate
II	1000	1500
III	1350	2000
IV	2000	3000

Note—Test load in pounds per linear foot equals D-load x inside span in feet.

^AFor modified or special designs, see 7.3.

^Bf'c, ksi = minimum compressive strength of concrete in thousands of pounds-force per square inch.

^CAs an alternative to designs requiring double line reinforcement, the reinforcement may be positioned and proportioned so that the total reinforcement of the inner cage plus the middle cage shall not be less than that specified for the inner cage continuous basic reinforcement, and the additional reinforcement "U" and the total reinforcement of the outer cage plus the middle cage shall not be less than that specified for the outer cage continuous basic reinforcement and the additional reinforcement "V."

^DA_s = circumferential steel area in square inches per longitudinal foot of pipe barrel in each continuous basic cage and additional cages in area denoted "U" and "V." Dimensions "U" and "V" are measured on the center line of the culvert wall.

³ The last approved version of this historical standard is referenced on www.astm.org.

5. Basis of Acceptance

5.1 Unless otherwise designated by the owner at the time of, or before placing an order, there are two separate and alternative bases of acceptance. Independent of the method of acceptance, the pipe shall be designed to meet both the 0.01-in. crack and ultimate strength requirements.

5.1.1 *Acceptance on Basis of Plant Load Bearing Tests, Material Tests, and Inspection of Manufactured Pipe for Visual Defects and Imperfections*—Acceptability of the pipe in all diameters and classes produced in accordance with 7.1 or 7.2, shall be determined by the results of the three-edge-bearing tests as defined in 11.3.1; by such material tests as are required in accordance with 6.2, 6.3, 6.5, and 6.6, by an absorption test of the concrete from the wall of the pipe as required in 11.9; and by visual inspection of the finished pipe to determine its conformance with the accepted design and its freedom from defects.

5.1.2 *Acceptance on Basis of Material Tests and Inspection of Manufactured Pipe for Defects and Imperfections*—Acceptability of the pipe in all diameters and classes produced in accordance with 7.1 or 7.2 shall be determined by the results of such material tests as are required in 6.2, 6.3, 6.5, and 6.6; by crushing tests on concrete cores or cured concrete cylinders; by an absorption test of the concrete from the wall of the pipe for each mix design that is used on an order; and by inspection of the finished pipe, including amount and placement of reinforcement, to determine its conformance with the accepted design and its freedom from defects.

5.1.3 When agreed upon by the owner and the manufacturer, any portion or any combination of the tests itemized in 5.1.1 or 5.1.2 may form the basis of acceptance.

5.2 *Age for Acceptance*—Pipe shall be considered ready for acceptance when they conform to the requirements as indicated by the specified tests.

6. Materials

6.1 *Reinforced Concrete*—The reinforced concrete shall consist of cementitious materials; mineral aggregates; admixtures, if used; and water in which steel has been embedded in such a manner that the steel and concrete act together.

6.2 *Cementitious Materials:*

6.2.1 *Cement*—Cement shall conform to the requirements for portland cement of Specification C150/C150M, or shall be portland blast-furnace slag cement, portland-limestone cement, or portland-pozzolan cement conforming to the requirements of Specification C595/C595M, except that the pozzolan constituent in the Type IP portland-pozzolan cement shall be fly ash.

6.2.2 *Slag Cement*—Slag cement shall conform to the requirements of Grade 100 or 120 of Specification C989/C989M.

6.2.3 *Fly Ash*—Fly ash shall conform to the requirements of Class F or Class C of Specification C618.

6.2.4 *Allowable Combinations of Cementitious Materials*—The combination of cementitious materials used in the concrete shall be one of the following:

6.2.4.1 Portland cement only,

6.2.4.2 Portland blast-furnace slag cement only,

6.2.4.3 Portland-pozzolan cement only,

6.2.4.4 Portland-limestone cement only,

6.2.4.5 A combination of portland cement or portland-limestone cement and slag cement,

6.2.4.6 A combination of portland cement or portland-limestone cement and fly ash,

6.2.4.7 A combination of portland cement or portland-limestone cement, slag cement, and fly ash, or

6.2.4.8 A combination of portland-pozzolan cement and fly ash.

6.3 *Aggregates*—Aggregates shall conform to the requirements of Specification C33/C33M except that the requirement for gradation shall not apply.

6.4 *Admixtures*—The following admixtures and blends are allowable:

6.4.1 Air-entraining admixture conforming to Specification C260/C260M;

6.4.2 Chemical admixture conforming to Specification C494/C494M;

6.4.3 Chemical admixture for use in producing flowing concrete conforming to Specification C1017/C1017M; and

6.4.4 Chemical admixture or blend approved by the owner.

6.5 *Steel Reinforcement*—Reinforcement shall consist of wire or welded wire conforming to Specification A1064/A1064M, or of bars conforming to Specification A36/A36M, Specification A615/A615M Grade 40 or 60, or Specification A706/A706M Grade 60. For helically wound cages only, weld shear tests are not required.

6.6 *Fibers*—Synthetic fibers and nonsynthetic fibers shall be allowed to be used, at the manufacturer's option, in concrete pipe as a nonstructural manufacturing material. Synthetic fibers (Type II and Type III) and nonsynthetic fiber (Type I) designed and manufactured specifically for use in concrete and conforming to the requirements of Specification C1116/C1116M shall be accepted.

6.7 *Water*—Water used in the production of concrete shall be potable or nonpotable water that meets the requirements of Specification C1602/C1602M.

7. Design

7.1 *Size and Dimensions*—The standard sizes of arch pipe are listed in Table 1. The internal dimensions for each standard size shall be as defined in Fig. 1, subject to the permissible variations of Section 12.

<https://standards.iteh.ai/catalog/standards/sist/21dda7e5-bda9-465f-9751-c63204b2e1a2/astm-c506-22a>

7.2 *Design Tables*—The wall thickness, compressive strength of concrete, and the area of circumferential reinforcement shall be as prescribed in Table 1, subject to the provisions of 7.3 and Sections 11 and 12.

7.2.1 Footnotes to the tables herein are intended to be amplifications of the tabulated requirements and are to be considered applicable and binding as if they were contained in the body of the specification.

7.3 Modified and Special Designs:

7.3.1 If permitted by the owner, the manufacturer may request approval by the owner of modified designs that differ from the designs in this Section 7 or special designs for sizes and loads beyond those shown in Table 1, or special designs for pipe sizes that do not have steel reinforcement areas shown in Table 1.

7.3.2 Such modified or special designs shall be based on rational or empirical evaluations of the ultimate strength and cracking behavior of pipe and shall fully describe to the owner any deviations from the requirements of this Section 7. The descriptions of modified or special designs shall include the wall thickness, the concrete strength, and the area, type, placement, number of layers, and strength of the steel reinforcement.

7.3.3 The manufacturer shall submit to the owner proof of the adequacy of the proposed modified or special design. Such proof may comprise the submission of certified three-edge-bearing tests already made, which are acceptable to the owner or, if such three-edge-bearing tests are not available or acceptable, the manufacturer may be required to perform proof tests on sizes and classes selected by the owner to demonstrate the adequacy of the proposed design.

7.3.4 Such pipe must meet all of the test and performance requirements specified by the owner in accordance with Section 5.

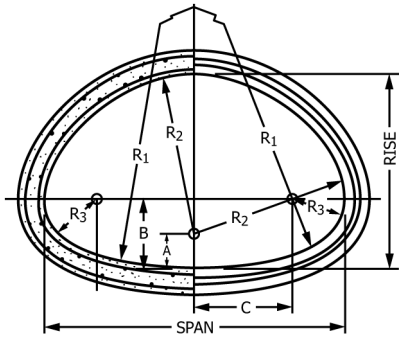

$$A = \text{Rise} - R_2$$

$$B = A + \sqrt{(R_2 - R_3)^2 - C^2}$$

$$C = \frac{\text{Span}}{2} - R_3$$

Approximate Equivalent Round Size, in.	Water Area, ft ²	Rise, in.	Span, in.	A, in.	B, in.	C, in.	R ₁ , in.	R ₂ , in.	R ₃ , in.
15	1.1	11	18	3/8	4 11/16	4 31/32	22 7/8	10 5/8	4 1/32
18	1.65	13 1/2	22	-1/4	6	5 3/4	27 1/2	13 3/4	5 1/4
21	2.2	15 1/2	26	3/4	6 1/4	7 3/4	35 1/2	14 3/4	5 1/4
24	2.8	18	28 1/2	37/16	5 29/32	9 21/32	40 11/16	14 9/16	4 19/32
30	4.4	22 1/2	36 1/4	3 3/4	7 11/16	12 3/32	51	18 3/4	6 1/32
36	6.4	26 5/8	43 3/4	4 1/8	8 9/16	15 1/2	62	22 1/2	6 5/8
42	8.8	31 5/16	51 1/8	5 1/16	10 1/16	18	73	26 1/4	7 9/16
48	11.4	36	58 1/2	6	11 19/32	20 1/2	84	30	8 3/4
54	14.3	40	65	6 5/8	13	22 11/16	92 1/2	33 3/8	9 13/16
60	17.7	45	73	7 1/2	14 11/16	25 9/32	105	37 1/2	11 7/32
72	25.6	54	88	9	17	31 7/16	126	45	12 9/16
84	34.6	62	102	10	18 21/32	37 1/32	162 1/2	52	13 31/32
90	44.5	72	115	13	23 13/16	38 7/32	183	59	19 9/32
96	51.7	77 1/4	122	15 1/4	24 11/32	40 15/16	218	62	20 1/16
108	66.0	87 1/8	138	17 1/8	26 27/32	46 5/8	269	70	22 3/8
120	81.8	96 7/8	154	18 7/8	29 7/32	53	301 3/8	78	24
132	99.1	106 1/2	168 3/4	20 7/8	32 15/16	57 1/2	329	85 5/8	26 7/8

FIG. 1 Cross-Sectional Shape of Arch Pipe

7.4 Area—In this specification, when the word area is not described by adjectives, such as cross-section or single wire, it shall be understood to be the cross-sectional area of reinforcement per unit lengths of pipe.

8. Reinforcement

8.1 Circumferential Reinforcement—A line of circumferential reinforcement for any given total area may be composed of two layers for pipe with wall thicknesses of less than 7 in. or three layers for pipe with wall thicknesses of 7 in. or greater. The layers shall not be separated by more than the thickness of one longitudinal plus 1/4 in. The multiple layers shall be fastened together to form a single cage. All other specification requirements such as laps, welds, and tolerances of placement in the wall of the pipe, etc., shall apply to this method of fabricating a line of reinforcement.

8.1.1 Where one line of reinforcement is used, it shall be placed so that the cover of the concrete over the circumferential reinforcement at the vertical and horizontal diameters of the pipe is 1 in. from the inside and outside surfaces of the pipe, except for wall thicknesses less than 2 1/2 in., the protective cover of the concrete over the circumferential reinforcement in the wall of the pipe shall be 3/8 in.

8.1.2 Where two lines of reinforcement of arch shape corresponding to the contour of the pipe are used, each line shall be so placed that the covering of concrete over the reinforcement is 1 in.

8.1.3 The location of the reinforcement shall be subject to the permissible variations in dimensions given in 12.5. Requirements for placement and protective covering of the concrete from the inner or outer surface of the pipe do not apply to that portion of a cage which is flared so as to extend into the bell or reduced in diameter so as to extend into the spigot.

8.1.3.1 Where the wall reinforcement does not extend into the joint, the maximum longitudinal distance to the last circumferential from the inside shoulder of the bell or the shoulder of the spigot shall be 3 in. except that if this distance exceed one-half the wall

thickness, the pipe wall shall contain at least a total reinforcement area of the minimum specified area per linear foot times the laying length of the pipe section. The minimum cover on the last circumferential near the spigot shoulder shall be ½ in.

8.1.3.2 Where the reinforcement is in the bell or spigot the minimum end cover on the last circumferential shall be ½ in. in the bell or ¼ in. in the spigot.

8.1.4 The spacing center to center of circumferential reinforcement in a cage shall not exceed 4 in. for pipe up to and including pipe having a 4-in. wall thickness nor exceed the wall thickness for larger pipe, and shall in no case exceed 6 in.

8.1.5 The continuity of the circumferential reinforcing steel shall not be destroyed during the manufacture of the pipe, except that when agreed upon by the owner, lift eyes or holes may be provided in each pipe for the purpose of handling.

8.1.6 If splices are not welded, the reinforcement shall be lapped not less than 20 diameters for deformed bars and deformed cold-worked wire, and 40 diameters for plain bars and cold-worked wire. The measurement of this lap length shall be tip-to-tip from the ends of the circumferential wires. In addition, where lapped cages of welded wire reinforcement are used without welding, the lap shall contain a longitudinal wire.

8.1.6.1 When splices are welded and are not lapped to the minimum requirements above, there shall be a minimum lap of 2 in. and a weld such that pull tests of representative specimens shall develop at least 50 % of the minimum specified tensile strength of the steel. For butt-welded splices in bars or wire, permitted only in helically wound cages, pull tests of representative specimens shall develop at least 75 % of the minimum specified tensile strength of the steel. Pull tests shall conform to Test Methods C497.

8.1.6.2 When requested by the owner, the manufacturer shall submit proof of the adequacy of welded splices. Such proof includes weld pull tests already made that are acceptable to the owner or, if such tests are not available or acceptable, pull tests on representative samples selected by the owner to demonstrate the adequacy of the welded splice.

8.2 *Longitudinal Reinforcement*—Each line of circumferential reinforcement shall be assembled into a cage that shall contain sufficient longitudinal bars or members, to maintain the reinforcement in shape and in position within the form to comply with permissible variations in 8.1. The exposure of the ends of longitudinals, stirrups, or spacers that have been used to position the cages during the placement of the concrete shall not be a cause for rejection.

8.3 *Joint Reinforcement*—In all pipe 36 in. or larger in diameter either the bell or the spigot of the joint shall contain circumferential reinforcement.

<https://standards.iteh.ai/catalog/standards/sist/21dda7e5-bda9-465f-9751-c63204b2e1a2/astm-c506-22a>

8.3.1 For single-cage pipe, joint reinforcement shall be at least equal in area to that required for an equivalent length of pipe wall.

8.3.2 For double-cage and triple-cage pipe, joint reinforcement shall be at least equal in area to that required for an equivalent length of the outer circular cage if placed in the bell, or at least equal in area to that required for an equivalent length of the inner circular cage if placed in the spigot.

9. Joints

9.1 The joints shall be of such design and the ends of the concrete pipe sections so formed that the pipe can be laid together to make a continuous line of pipe compatible with the permissible variations given in Section 12.

9.2 Joints shall conform to the requirements of Specification C990, C1896, or other established joint types approved by the owner, including, but not limited to, mortar, sealant or externally-wrapped joints.

10. Manufacture

10.1 *Mixture*—The aggregates shall be sized, graded, proportioned, and mixed with such proportions of cementitious materials, water, and admixtures, if any, to produce a thoroughly mixed concrete of such quality that the pipe will conform to the test and design requirements of this specification. All concrete shall have a water-cementitious materials ratio not exceeding 0.53 by weight. Cementitious materials shall be as specified in 6.2 and shall be added to the mix in a proportion not less than 470 lb/yd³ unless mix designs with a lower cementitious materials content demonstrate that the quality and performance of the pipe meet the requirements of this specification.

10.1.1 *Mixing Water*—Water used in the production of concrete shall be potable or non-potable water that meets the requirement of Specification **C1602/C1602M**.

10.2 *Curing*—Pipe shall be subjected to any one of the methods of curing described in **10.2.1 – 10.2.3**, or to any other method or combination of methods approved by the owner, that will give satisfactory results. The pipe shall be cured for a sufficient length of time so that the specified D-load is obtained when acceptance is based on **5.1.1** or so that the concrete will develop the specified compressive strength at 28 days or less when acceptance is based on **5.1.2**.

10.2.1 *Steam Curing*—Pipe shall be placed in a curing chamber, free of outside drafts, and cured in a moist atmosphere maintained by the injection of live steam for such time and such temperature as needed to enable the pipe to meet the strength requirements. At no time shall the ambient temperature exceed 160°F. The curing chamber shall be so constructed as to allow full circulation around the inside and outside of the pipe.

10.2.2 *Water Curing*—Concrete pipe may be water-cured by covering with water-saturated material or by a system of perforated pipes, mechanical sprinklers, porous hose, or by any other approved method that will keep the pipe moist during the specified curing period.

10.2.3 A sealing membrane conforming to the requirements of Specification **C309** may be applied and should be left intact until the required strength requirements are met. The concrete at the time of application shall be within 10°F of the atmospheric temperature. All surfaces shall be kept moist prior to the application of the compounds and shall be damp when the compound is applied.

10.2.4 The manufacturer may, at his option, combine the methods described in **10.2.1** to **10.2.3** as long as the required concrete compressive strength is attained.

11. Physical Requirements

11.1 *Test Specimens*—The specified number of pipe required for the tests shall be furnished without charge by the manufacturer, shall be selected at random by the owner, and shall be pipe that would not otherwise be rejected under this specification. The selection shall be made at the point or points designated by the owner when placing the order.

11.2 *Number and Type of Tests Required for Various Delivery Schedules:*

11.2.1 *Small Orders*—Small orders are those that consist of less than 100 pieces of each size and class of pipe. The owner of such an order shall be entitled to copies of test reports as are routinely performed on the particular lot, as required by the type and basis of acceptance specified by the owner in Section **5**. A lot shall include up to five consecutive days of production, or 100 pieces, whichever is greater, provided the process and mix design is not altered in any way between production days.

11.2.2 *Large Orders*—For orders of 100 or more pieces of a size and class, the owner shall be entitled to tests per Section **5** on not more than one pipe per lot except where **11.2.3** and **11.2.4** are applicable.

11.2.3 *Tests for Extended Delivery Schedules for Large Orders*—An owner of pipe, whose needs require shipments at intervals over extended periods of time, shall be entitled to such tests, preliminary to delivery of pipe, as required by the type of basis of acceptance specified by the owner in Section **5**, of not more than three sections of pipe covering each size in which the owner is interested.

11.2.4 *Additional Tests for Extended Delivery Schedules*—An owner shall be entitled to additional tests at such times as the owner may deem necessary, provided that the total number of pipe tested shall not exceed one pipe or 1 %, whichever is greater, of each size and class of pipe in the original order.

11.3 *External Load Crushing Strength:*

11.3.1 The load required to produce a 0.01-in. crack or the ultimate load, as determined by the three-edge-bearing method described in Test Methods **C497** shall be not less than that prescribed in **Table 1** for each respective class of pipe. Pipe that have been tested only to the formation of a 0.01-in. crack and that meet the 0.01-in. crack load requirements shall be accepted for use.