



Designation: **D5156–02 (Reapproved 2016) D5156 – 22**

## Standard Test Methods for Continuous Measurement of Ozone in Ambient, Workplace, and Indoor Atmospheres (Ultraviolet Absorption)<sup>1</sup>

This standard is issued under the fixed designation D5156; the number immediately following the designation indicates the year of original adoption or, in the case of revision, the year of last revision. A number in parentheses indicates the year of last reapproval. A superscript epsilon ( $\epsilon$ ) indicates an editorial change since the last revision or reapproval.

### 1. Scope

1.1 This test method describes the sampling and continuous analysis of ozone ( $O_3$ ) in the atmosphere at concentrations ranging from 10 to 2000  $\mu\text{g}/\text{m}^3$  of  $O_3$  in air (5 ppb(v) to 1 ppm(v)).

1.1.1 The test method is limited to applications by its sensitivity to interferences as described in Section 6. The interference sensitivities may limit its use for ambient and workplace atmospheres.

1.2 The values stated in SI units are to be regarded as standard. No other units of measurement are included in this standard.

1.3 *This standard does not purport to address all of the safety concerns, if any, associated with its use. It is the responsibility of the user of this standard to establish appropriate safety, health, and environmental practices and determine the applicability of regulatory limitations prior to use.*

1.4 *This international standard was developed in accordance with internationally recognized principles on standardization established in the Decision on Principles for the Development of International Standards, Guides and Recommendations issued by the World Trade Organization Technical Barriers to Trade (TBT) Committee.*

### 2. Referenced Documents

#### 2.1 ASTM Standards:<sup>2</sup>

D1356 Terminology Relating to Sampling and Analysis of Atmospheres

D1357 Practice for Planning the Sampling of the Ambient Atmosphere

D1914 Practice for Conversion Units and Factors Relating to Sampling and Analysis of Atmospheres

D3249 Practice for General Ambient Air Analyzer Procedures

D3631 Test Methods for Measuring Surface Atmospheric Pressure

D3670 Guide for Determination of Precision and Bias of Methods of Committee D22

D5011 Practices for Calibration of Ozone Monitors Using Transfer Standards

D5110 Practice for Calibration of Ozone Monitors and Certification of Ozone Transfer Standards Using Ultraviolet Photometry

IEEE/ASTM SI-10 Practice for Use of the International System of Units (SI) (the Modernized Metric System)

#### 2.2 Other Documents:

EPA-600/4-76-005 *Quality Assurance Handbook for Air Pollution Measurement Systems, Vol I, "Principles"*<sup>3</sup>

<sup>1</sup> These test methods are under the jurisdiction of ASTM Committee D22 on Air Quality and is the direct responsibility of Subcommittee D22.03 on Ambient Atmospheres and Source Emissions.

Current edition approved Oct. 1, 2016; Sept. 1, 2022. Published October 2016/September 2022. Originally approved in 1991. Last previous edition approved in 2008/2016 as D5156 – 02 (2008)/(2016). DOI: 10.1520/D5156-02R16.10.1520/D5156-22.

<sup>2</sup> For referenced ASTM standards, visit the ASTM website, www.astm.org, or contact ASTM Customer Service at service@astm.org. For *Annual Book of ASTM Standards* volume information, refer to the standard's Document Summary page on the ASTM website.

<sup>3</sup> Available from National Technical Information Service (NTIS), 5301 Shawnee Rd., Alexandria, VA 22312, http://www.ntis.gov.

### 3. Terminology

3.1 *Definitions*—For definitions of terms used in this test method, refer to Terminology **D1356**. An explanation of units, symbols, and conversion factors may be found in Practice **IEEE/ASTM SI-10**.

3.2 *Definitions of Terms Specific to This Standard:*

3.2.1 *absolute ultraviolet photometer*—a photometer whose design, construction, and maintenance is such that it can measure the absorbance caused by O<sub>3</sub> mixtures without reference to external absorption standards. Given a value for the absorption coefficient of O<sub>3</sub> at 253.7 nm and a reading from the absolute ultraviolet photometer, O<sub>3</sub> concentrations can be calculated with accuracy. An absolute ultraviolet photometer is used only on prepared O<sub>3</sub> mixtures free from interferences, as in calibration activity.

3.2.2 *primary standard*—a standard directly defined and established by some authority, against which all secondary standards are compared.

3.2.3 *secondary standard*—a standard used as a means of comparison, but checked against a primary standard.

3.2.4 *standard*—an accepted reference sample or device used for establishing the measurement of a physical quantity.

3.2.5 *transfer standard*—a type of secondary standard; it is a transportable device or apparatus that, together with operational procedures, is capable of reproducing pollutant concentrations or producing acceptable assays of pollutant concentrations.

### 4. Summary of Test Method

4.1 This test method is based on the absorption of ultraviolet radiation at 253.7-nm wavelength by O<sub>3</sub> and the use of an ozone-specific scrubber to generate a reference air stream with only O<sub>3</sub> scrubbed from it. A single-cell ultraviolet absorption photometer is used, with the cell filled alternately with ambient and O<sub>3</sub>-scrubbed ambient air. The absorption to be measured at the lower part of the operating range is extremely small. Special precautions and designs must be used to obtain accurate results.

4.2 The absorption of radiation at 253.7 nm by O<sub>3</sub> at very low concentrations follows the Beer-Lambert Law. Namely, for a cell of length  $d$ , assuming a constant input ultraviolet intensity, the ratio of the emerging intensities for the cell filled with sample air,  $I_s$ , and with O<sub>3</sub>-scrubbed air,  $I_o$ , is:

$$\frac{I_s}{I_o} = e^{-(cad)} \quad (1)$$

where:

$c$  = the concentration of O<sub>3</sub>, ppm (v),

$d$  = the length of the cell, cm, and

$a$  = the absorption coefficient of O<sub>3</sub> per length unit of  $d$  and per concentration unit of  $c$ .

4.3 When  $(cad)$  is  $\ll 1$ , as is the case for O<sub>3</sub> at 253.7 nm in the concentration range specified for this test method, the approximation

$$e^{-x} \approx (1 - x) \quad (2)$$

can be used to simplify the signal processing electronics, so that

$$I_s \approx I_o (1 - cad) \quad (3)$$

and thus

$$c \approx \frac{(I_o - I_s)}{I_o ad} \quad (4)$$

4.4 At 1 ppm (v), the high end of the recommended range, and a path length of 50 cm, the error resulting from application of the above approximation is approximately 1 part in 10 000.

4.5 Thus, the concentration of O<sub>3</sub> can be obtained from the difference between the signal from the photosensor (often a vacuum photodiode) when the contents of the absorption cell contain sample air from which O<sub>3</sub> has been scrubbed, and when it contains sample air containing O<sub>3</sub>.

4.6 At 5 ppb (v) with a 50-cm path length, the absorption is approximately  $308 \times 0.005 \times 50 \times 10^3$  or  $0.30439 \times 0.005 \times 50 \times 10^{-6}$  or  $\times 10^{-5}$  (**1-45**).<sup>4</sup>

4.7 The instrument is calibrated by methods given in Practices **D5011** and **D5110**, which describe the use of an absolute ultraviolet photometer as a primary standard and the qualification and use of transfer standards.

## 5. Significance and Use

5.1 Standards for O<sub>3</sub> in the atmosphere have been promulgated by government authorities to protect the health and welfare of the public (**56**) and also for the protection of industrial workers (**67**).

5.2 Although O<sub>3</sub> itself is a toxic material, in ambient air it is primarily the photochemical oxidants formed along with O<sub>3</sub> in polluted air exposed to sunlight that cause smog symptoms such as lachrymation and burning eyes. Ozone is much more easily monitored than these photochemical oxidants and provides a good indication of their concentrations, and it is therefore the substance that is specified in air quality standards and regulations.

## 6. Interferences

6.1 Any aerosol or gas that absorbs or scatters ultraviolet radiation at 253.7 nm, and that is removed by the O<sub>3</sub>-specific scrubber, constitutes an interferent (**78**) to this test method (**89**). Particulate matter can be removed with a poly-tetrafluoroethylene (PTFE) membrane filter. Any type of filter can, however, become contaminated and may then scrub O<sub>3</sub>. It is important to check the O<sub>3</sub>-inertness of such devices frequently.

6.2 Some reported positively interfering organic species for a manganese dioxide scrubber are tabulated in **Annex A2** of this test method. In general, if interferences are suspected, it is preferable to use another test method rather than to try to scrub out the interfering agent, since the instability of O<sub>3</sub> makes the testing and proving of additional interferant scrubbers particularly difficult.

6.3 Water vapor may constitute either a positive or negative interferant in instruments calibrated with dry span gas (**9-10-1213**).

6.3.1 Improperly polished absorption cell windows may lead to increased signal noise and apparent ozone increases in instruments subject to rapidly changing humidity, such as at a coastal site where instruments may be exposed to frequent shifts between relatively dry terrestrial and moist oceanic air parcels (**89**).

6.3.2 A negative water vapor interference, due to humidity dependent changes in elution rates of interferences from the ozone scrubber may develop in manganese dioxide scrubbers exposed to ambient air (**1011, 1213, 1314**). This phenomenon is described in **7.2.6**.

## 7. Apparatus

7.1 Instruments are commercially available that meet the specifications provided in **Annex A1**. Note that these specifications do not cover operation where the ambient temperature changes rapidly.

7.2 The elements of the typical ozone-measuring system are shown in **Fig. 1**. Assembled, they form a photometric ultraviolet monitor with specifications conforming to those listed in **Annex A1**. The components are described in **7.2.1 – 7.2.8**.

7.2.1 *Ultraviolet Absorption Cell*, constructed of materials inert to O<sub>3</sub>, for example, PTFE-coated metal, borosilicate glass, and fused silica. It shall be mechanically stable so that the optical alignments of the source, sensor, and any beam-directing devices (mirror, prisms, or lenses) are not affected by changes in ambient temperature (**Fig. 1(F)**).

<sup>4</sup> The boldface numbers in parentheses refer to the list of references at the end of this test method.

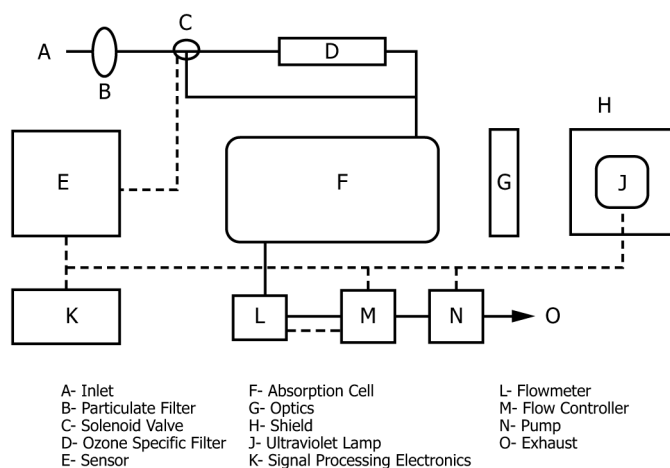

FIG. 1 Schematic Diagram of a Typical Ultraviolet Photometer

7.2.2 *Ultraviolet Lamp*—A low-pressure mercury vapor discharge lamp enclosed in a shield to prevent its radiation at 185-nm 185 nm (which generates O<sub>3</sub>) from reaching the absorption cell (Fig. 1(J)).

7.2.2.1 The lamp output at 253.7 nm shall be extremely stable, or provision shall be made to compensate for short-term variations at 253.7-nm output, for example, by the use of a lamp-intensity monitor to measure output from the lamp and with electronics to adjust the signal from the ultraviolet sensors correspondingly.

7.2.2.2 *Shield*, constructed of high-silica glass<sup>5</sup> to remove the 185-nm line and permit the transmission at 253.7-nm radiation (Fig. 1(H)).

7.2.3 *Particulate Filter*, installed in the sample line to prevent aerosols or particulate matter from entering the measuring system. PTFE fluorocarbon filters with pore sizes between 0.2 and 5.0 μm shall be used. The filter shall be replaced frequently since accumulated materials on the filter may catalyze the breakdown of O<sub>3</sub> into oxygen (Fig. 1(B)).

7.2.4 *Sensor*—Vacuum photodiodes with cesium telluride photocathode sensitivity at 253.7-nm radiation and negligible sensitivity to the other mercury lamp lines. The response at 253.7 nm shall be extremely stable over the short-term periods of the sampling cycle, of the same order as the stability demanded of the ultraviolet source. Temperature stabilization and a well-regulated photosensor supply voltage shall be provided to achieve the necessary stability (Fig. 1(E)).

7.2.5 *Three-Way PTFE Solenoid Valve*, constructed with internal parts of, or coated with, PTFE fluorocarbon or other material that will not catalyze the destruction of O<sub>3</sub>, to route the sample through or to bypass the O<sub>3</sub> selective scrubber (Fig. 1(C)).

7.2.6 *Ozone-Specific Scrubber*, containing a material that selectively catalyzes the destruction of O<sub>3</sub> without altering or adding any other compound. Manganese dioxide on a substrate and heated silver wool have been found generally to perform this function. However, several aromatic organic compounds identified in Annex A2 have been shown to be adsorbed by manganese dioxide. Some compounds may be adsorbed partly, producing at first an apparent higher concentration of O<sub>3</sub>, followed by a falsely lower concentration as the material is desorbed (1011). Mean O<sub>3</sub> values are not affected by reversibly adsorbed species when averaging times are much longer than that of the absorption-desorption cycle, provided that the possible “negative” O<sub>3</sub> values that result from the desorption of the interferant while actual O<sub>3</sub> values are very low or zero are included in the mean. This may not be true where hourly averages are calculated by simple arithmetical averaging of instantaneous values taken within a 1-h period, or where the instrument contains a zero clamp that prevents negative values from being output (Fig. 1(D)). After exposure to ambient air, some manganese dioxide ozone scrubbers may develop anomalous sensitivity to water vapor. Since such anomalous scrubbers regain normality at low humidity, their anomalous behavior can not be detected during span gas calibrations using dry zero air. *Scrubber efficiency tests must be conducted with wet span gas to identify such anomalous manganese dioxide cartridges (1415, 1516).*

7.2.7 *Pump*—A small air pump to pull the sample air through the instrument (Fig. 1(N)).

<sup>5</sup> “Vycor” brand material has been found to be satisfactory.

7.2.8 *Flowmeter*, to verify that air is moving through the instrument (Fig. 1(L)).

7.3 *Internal Lines and Fittings*, in the sample stream prior to the adsorption cell and the scrubber, constructed of PTFE fluorocarbon or other O<sub>3</sub>-inert material.

7.4 *Signal Processing Electronics*, containing several distinct elements (Fig. 1(K)):

7.4.1 Circuits to condition the signal from the ultraviolet-sensitive sensor (diode) with short-term stability.

7.4.2 Timing and control circuits to operate the flow switching valves and different phases of the signal conditioning circuits.

7.4.3 Circuits to generate mean values from the signals from the sensor (diode) interface circuits for the two parts of the cycle, to subtract them, and to output the resultant differences in a scaled form. The circuits shall also compensate for temperature and pressure so that the adsorption measured is proportional to the gas density in the absorption cell.

7.4.4 The concentration of O<sub>3</sub> can be obtained from the ratio of the sensor (diode) signals when the adsorption cell contains sample air from which O<sub>3</sub> has been scrubbed, to when it contains sample air containing O<sub>3</sub>. The conversion of this value to parts per million by volume shall include correction for ambient temperature and barometric pressure according to the ideal gas law. The correction can be ignored if errors as great as  $\pm 5\%$  are acceptable. Some commercially available instruments correct automatically for actual measurement temperature and pressure in their concentration outputs.

7.4.5 Signal processing shall not prevent the output of negative values, which may arise from instrument malfunction, from random fluctuations in measurements of  $I_s$  and  $I_o$  in the absence of O<sub>3</sub>, and from interferences being desorbed from the O<sub>3</sub>-selective scrubber.

7.5 *Ports*, included in the instrument at the entry and exit of the adsorption cell. These are helpful in determining whether O<sub>3</sub> is being destroyed in the cell. The calibration method given in Practice D5110 describes how the ports are used.

7.6 *Barometer*, to measure and record atmospheric pressure during sampling, in accordance with Test Methods D3631.

7.7 *Temperature Measuring Equipment*, to measure and record ambient temperature during sampling.

## 8. Hazards

8.1 See Practice D3249 for general safety precautions in using instruments.

8.2 The wavelength used for adsorption measurements is in the extreme ultraviolet, where eye damage is possible if the lamp is viewed directly.

8.3 When calibrating the instrument, vent the excess gas mixture through a charcoal filter. This will prevent contamination of the work area around the instrument with O<sub>3</sub>, which, at the concentrations encountered at the high end of the method's range, can induce headaches and, occasionally, nausea.

## 9. Sampling

9.1 Sampling of the atmosphere shall be conducted in accordance with the guidelines given in Practices D1357 and D3249. These recommended practices point out the need for avoiding sites that are closer than a 50-m distance from traffic, which could lead to transient hydrocarbon and nitrogen oxide interferences.

9.2 The sampling lines shall be made of PTFE fluorocarbon with an inside diameter between 4 and 7 mm. The sampling line shall be short and direct, preferably not more than 5 m in length.

9.3 Since O<sub>3</sub> in ambient air is created and destroyed in a series of interacting chemical reactions of varying speeds, driven by

sunlight in the presence of hydrocarbon and nitrogen oxide gases, the ambient O<sub>3</sub> concentration found in a shady location under calm air conditions may be quite different from that found only a few metres away in bright sunshine.

9.4 Although the test method is not directly dependent on the flow rate of the sample, the sample flow shall be sufficient to flush the adsorption cell thoroughly between the two cycles, as well as to ensure that the residence time in the sample line does not affect the O<sub>3</sub> concentration passing through it (~~1617~~).

9.5 Measure and record the ambient temperature and pressure during sampling.

## 10. Calibration and Standardization

10.1 The calibration of O<sub>3</sub> monitors and the certification of transfer standards using an absolute ultraviolet photometer are described in Practice D5110 (~~1718~~, ~~1819~~). The use of transfer standards thus certified is described in Practices D5011 (~~1920~~).

## 11. Procedure and Maintenance

11.1 Site the monitor with consideration of Practice D1357 and other applicable documents (for example, EPA-600/4-77-027a) (~~2021~~).

11.2 Sample the atmosphere with a probe having nonreactive inside walls such as PTFE fluorocarbon or glass. Keep the probe clean and leak-test it monthly. Since the sample flow into the instrument should be kept free of particulate matter, change the PTFE fluorocarbon filter used to achieve this frequently, depending on the area being monitored. Each month, check the degree to which the concentration of O<sub>3</sub> in the sample atmosphere is affected by the probe and filter by passing calibration gases to the monitor directly, and then via the probe and filter, and observing the difference in response.

11.3 When the outside ambient air is hot and humid, neither the sample nor its path through the instrument shall be cooled to the point at which condensation occurs, since O<sub>3</sub> is both soluble in and possibly destroyed by condensate although Kleindeinst et al. (~~112~~) report little effect.

11.4 Avoid situations in which the analyzer will be exposed to rapid and frequent changes of ambient temperature. If, for example, the monitor is placed in a small sampling station that is cooled or heated by a high-capacity system, it shall be shielded from direct air flow from the air-conditioning system. Many instruments are well compensated for slow changes in ambient temperature, but do not respond well to the rapid changes often found in small air monitoring stations, which may exceed  $\pm 1^{\circ}\text{C}/\text{min}$ . Manganese dioxide ozone scrubber cartridges appear to be particularly susceptible to this effect, with reported ozone signal oscillations up to 40 ppb(v) that are associated with temperature functions  $(\pm 1^{\circ}\text{C})(\pm 1^{\circ}\text{C})$  in monitor shelters due to air conditioner cycling (~~1213~~). Heated silver metal scrubbers also show some sensitivity to fluctuations in temperature control (~~1415~~, ~~1516~~). Check instruments for calibration and baseline stability in the type of environment in which they are actually deployed.

11.5 Select a data recording system that matches the output of the monitor, and, in the case of a data logger or telemetry system, be sure that the sampling interval and data analysis method will detect and report instrument malfunctions such as excessive noise in the output, spikes, etc., and will not merely average them away. Verify that the dynamic range and precision of the recorder or data logger is wide enough to accommodate the range of concentrations expected. In the case of O<sub>3</sub> in the ambient atmosphere, the peak levels experienced very infrequently can be ten times greater than typical summer day levels. Automatic multi-ranging may help to retain accuracy at low levels while allowing for occasional high levels to be measured and recorded.

11.5.1 Recording or data logging devices shall identify calibration values positively. This can be achieved as simply as using a chart recorder and writing the information on the chart. An automatic data logger shall include a status signal recorded along with the instrument output information that will label calibration points as different from ambient measurements.

## 12. Calculation

12.1 To convert the O<sub>3</sub> found from ppb or ppm to  $\mu\text{g}/\text{m}^3$ , see Practice D1914.

## 13. Quality Assurance

13.1 Quality Assurance Handbooks EPA-600/4-76-005 and EPA-600/4-77-027a contain useful quality assurance criteria for performing this test method.

**TABLE 1 Precision Test Results of a Commercial Ultraviolet Photometer**

Test Day	0.5 ppm Range		1.0 ppm Range	
	O <sub>3</sub> Concentrations, ppm			
	0.1	0.4	0.2	0.8
1	0.00068 ppm	0.0025 ppm	0.00117 ppm	0.00216 ppm
2	0.00080	0.0029	0.00117	0.00207
3	0.00032	0.00093	0.00084	0.00082
4	0.00076	0.00074	0.00098	0.00160
5	0.00418	0.0025	0.00075	0.00251
6	0.00061	0.0022	0.00117	0.00210
7	0.00069	0.00102	0.00103	0.00210
Average	0.00113 ppm	0.00183 ppm	0.00102 ppm	0.00189 ppm

**TABLE 2 Comparison of Ozone Calibration Variability Procedure**

Procedure	N <sup>A</sup>	Mean Slope	O <sub>total</sub> <sup>B</sup>	Reproducibility
UV Photometry	10	1.0037	0.0123	0.0341
GPT-NO <sup>C</sup>	10	1.0742	0.0383	0.1062
GPT-O <sub>3</sub> <sup>D</sup>	9	1.0787	0.0669	0.1854
BAKI <sup>E</sup>	12	0.9865	0.0557	0.1544

<sup>A</sup> N = number of participating volunteers.

<sup>B</sup> O<sub>total</sub> = total random variability.

<sup>C</sup> GPT-NO = nitric oxide gas phase titration.

<sup>D</sup> GPT-O<sub>3</sub> = ozone gas phase titration.

<sup>E</sup> BAKI = boric acid buffered potassium iodide method.

## 14. Precision and Bias

### 14.1 Precision:

14.1.1 *Repeatability*—The standard deviation of determinations of an atmospheric sample, for a single instrument, is proportional to concentration. Results of the precision test described in Rehme et al. (2122) for one commercially available instrument are given in Table 1.

14.1.2 *Reproducibility*—The results of an interlaboratory comparison test (2223) in which ultraviolet photometers of the California Air Resources Board (ARB), the Environmental Protection Agency, Research Triangle Park (EPA/RTP), and the Jet Propulsion Laboratory (JPL) were compared with an absolute photometer of the National Institute of Standards and Technology (NIST). The results indicated excellent agreement, with a total variation of 2.8 %. Compared to the NIST photometer, the California ARB photometer read 0.4 % low, the EPA/RTP photometer read 1.3 % low, and the JPL photometer read 1.5 % high. The correlation coefficients of the same data sets were 0.9999, 1.0000, and 1.0000, respectively.

### 14.2 Bias:

14.2.1 The measuring system described in this test method produces relative values that depend on the accuracy of the calibration used and of its transfer. A study performed by EPA Environmental Monitoring Systems Laboratory (2122) determined the bias of four of the transfer method standards described in Practices D5011. The results are given in Table 2.

## 15. Keywords

15.1 ambient atmospheres; indoor atmospheres; monitoring; ozone; ultraviolet absorption; workplace atmospheres