



Standard Specification for Low Velocity Projectile Marker¹

This standard is issued under the fixed designation F2574; the number immediately following the designation indicates the year of original adoption or, in the case of revision, the year of last revision. A number in parentheses indicates the year of last reapproval. A superscript epsilon (ϵ) indicates an editorial change since the last revision or reapproval.

1. Scope

1.1 This specification covers low velocity projectile markers (herein referred to as LVP marker) that propel a low velocity resilient material projectile (herein referred to as LVRM projectile as defined in Specification F2573) by means of energy released by compressed air, compressed gas, or a combination thereof, with velocity not to exceed 53.34 m/s (175 ft/s).

1.2 LVRM projectiles are made of a resilient material and have a diameter no smaller than 20 mm (0.7874 in.) and no greater than 30 mm (1.18 in.). The hardness of the LVRM projectile is to be no greater than 75 Shore 00. The weight of the LVRM projectile is not to exceed 4.0 g.

1.3 The values stated in SI units are to be regarded as standard. The values given in parentheses are for information only.

1.4 The following precautionary caveat pertains only to the test method portion, Section 8, of this specification. *This standard does not purport to address all of the safety concerns, if any, associated with its use. It is the responsibility of the user of this standard to establish appropriate safety, health, and environmental practices and determine the applicability of regulatory limitations prior to use.*

1.5 *This international standard was developed in accordance with internationally recognized principles on standardization established in the Decision on Principles for the Development of International Standards, Guides and Recommendations issued by the World Trade Organization Technical Barriers to Trade (TBT) Committee.*

2. Referenced Documents

2.1 *ASTM Standards:*²

F1750 Specification for Paintball Marker Threaded-

Propellant Source Interface

F1776 Specification for Eye Protective Devices for Paintball Sports

F2573 Specification for Low Velocity Resilient Material Projectile

2.2 *ANSI Standard:*³

Z535.1 Safety Color Code

3. Terminology

3.1 *Definitions of Terms Specific to This Standard:*

3.1.1 *auto-trigger, n*—trigger that, when held in the discharge position, will automatically cause the LVP marker to discharge when the pump or bolt action is manipulated.

3.1.2 *backstop, n*—object intended to stop a LVRM projectile.

3.1.3 *barrel, n*—that portion of a LVP marker through which the LVRM projectile is discharged.

3.1.4 *barrel blocking device, n*—muzzle blocking safety device that when properly installed, reduces the likelihood of an intact LVRM projectile discharging from the marker or leaving the confines of the barrel blocking device. The device is often referred to as a barrel plug or sleeve.

3.1.5 *cautionary statement, n*—warning outlined in Section 9 that is to be placed on LVP markers, packaging, and literature.

3.1.6 *disabling device, n*—device that, when activated, disables a part of the LVP marker, usually the trigger, to prevent unintentional discharges and must be released to allow the marker to be discharged by the movement of the trigger. The device is sometimes referred to as the “safety,” “safety button,” or “safety lever.” An electronic on/off switch is considered a disabling device if when placed in the “off” position, it renders the marker inoperable.

3.1.7 *discharge mode, n*—mode that controls the number of LVRM projectiles discharged per trigger cycle.

3.1.8 *feed mechanism, n*—mechanism that stores, transports, and facilitates the loading of LVRM projectiles. It may be gravity, mechanically or air assisted, or automatic in its actions.

¹ This specification is under the jurisdiction of ASTM Committee F08 on Sports Equipment, Playing Surfaces, and Facilities and is the direct responsibility of Subcommittee F08.24 on Paintball and Equipment.

Current edition approved Sept. 1, 2022. Published October 2022. Originally approved in 2006. Last previous edition approved in 2018 as F2574 – 06 (2018). DOI: 10.1520/F2574-06R22.

² For referenced ASTM standards, visit the ASTM website, www.astm.org, or contact ASTM Customer Service at service@astm.org. For *Annual Book of ASTM Standards* volume information, refer to the standard’s Document Summary page on the ASTM website.

³ Available from American National Standards Institute (ANSI), 25 W. 43rd St., 4th Floor, New York, NY 10036.

3.1.9 *hopper, n*—device used with a LVP marker to store LVRM projectiles.

3.1.10 *impact tester, n*—device used to test for accidental discharges of LVP marker. See Fig. 1.

3.1.11 *low velocity resilient material projectile, n*—object propelled by means of a discharge mechanism, capable of storing and releasing energy under the control of the operator, comprised of a resilient material, and has a diameter no smaller

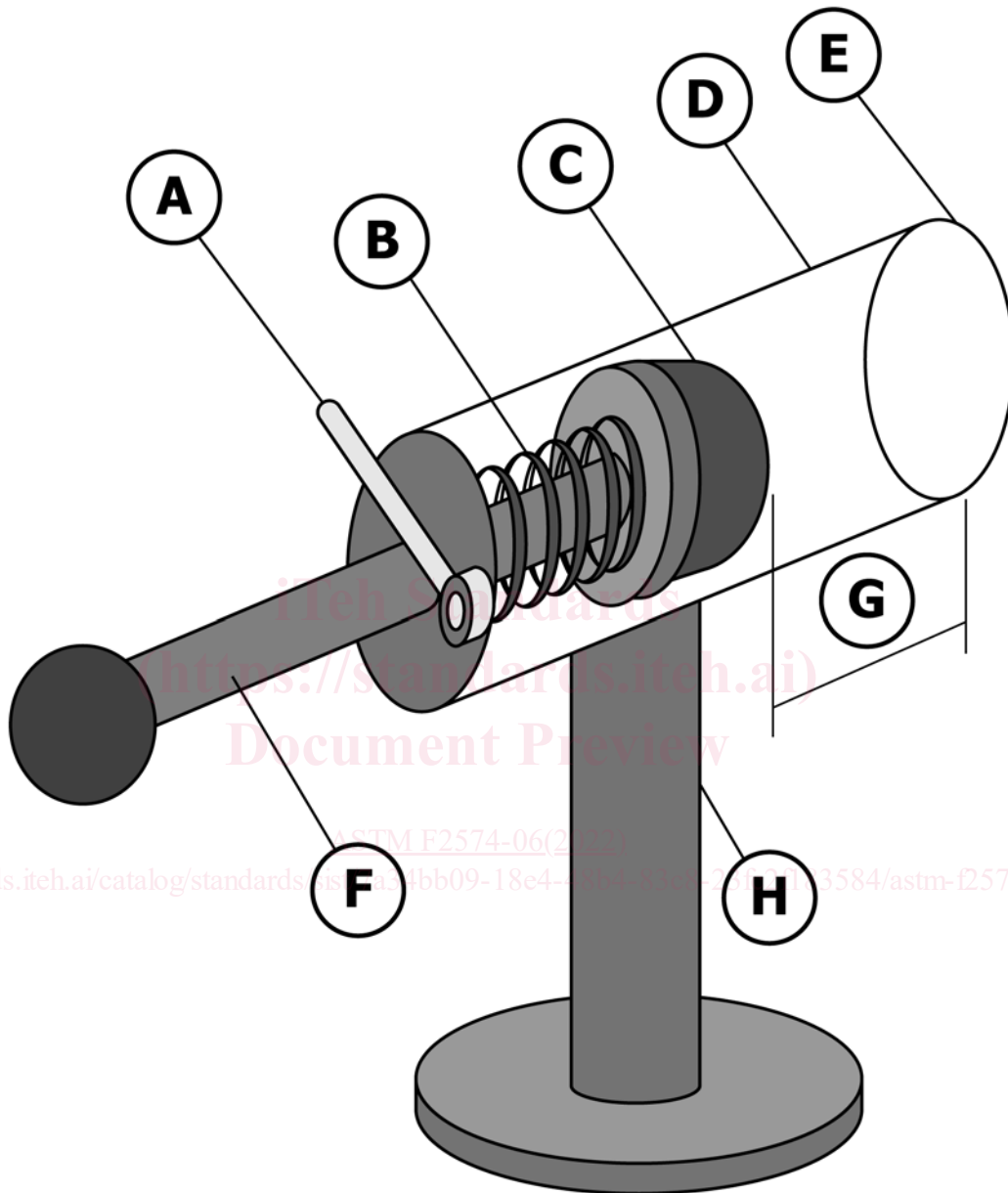

- A. Release Latch
- B. Compression Spring (spring rate 1.145 kg/cm or 16.28 lb/in.)
- C. Impact Ball (new pressurized tennis ball with regular felt, total mass of moving parts is 1.13 kg or 2.5 lb)
- D. Plastic tube with 7.62 cm (3 in.) internal diameter
- E. Face placed against marker
- F. Cocking arm
- G. Stroke of 15.21 cm (6 in.)
- H. Secured support base

FIG. 1 Impact Tester

than 20 mm (0.7874 in.) and no greater than 30 mm (1.18 in.). The hardness of the low velocity resilient material projectile is to be no greater than 75 Shore 00. The weight is not to exceed 4.0 g.

3.1.12 *low velocity projectile marker, n*—device specifically designed to discharge low velocity resilient material projectiles.

3.1.13 *pump mode marker, n*—marker that requires the operator to manually cock or engage the sear of the marker before each shot by a means of a pump, bolt, lever, cocking handle, or similar device.

3.1.14 *range, n*—maximum distance to which an object may be propelled, whether limited by energy or an obstacle.

3.1.15 *sear, n*—catch that holds the mechanism in the ready-to-discharge position until released by the user, usually through trigger movement.

3.1.16 *semi-automatic mode marker, n*—semi-automatic marker discharges one time with each trigger cycle. Markers that “store” the number of trigger pulls and discharge more than one LVRM projectile at some point do not meet this definition. Markers that operate in any other discharge mode(s) do not meet this definition.

3.1.17 *shore 00, n*—applicable durometer type scale to measure the hardness of sponge and foam materials.

3.1.18 *standard ambient temperature and pressure (SATP), n*—used to describe a substance at the pressure of 1 bar (1.01325 atmospheres, 750 mm Hg, 14.5 psi, 100 kPa) and a temperature of 25 °C (77 °F).

3.1.19 *target, n*—object at which the LVRM projectile shall be discharged.

3.1.20 *trigger, n*—device operated by the user to discharge a marker.

3.1.21 *trigger cycle, n*—movement of the trigger through discharge and returning to a reset or recycle position.

3.1.22 *trigger pull, n*—force required to move the trigger from its start or recycle/reset position to a position that discharges the marker.

4. Significance and Use

4.1 This specification establishes performance requirements and test methods for LVP markers.

4.2 This specification identifies the minimum warnings and instructions that are to be provided in literature, on labels, on packaging, and on the marker itself.

5. Conformance

5.1 LVP markers shall not, either by label or other means, indicate conformance with this specification, unless at the time of manufacture they conform to all applicable requirements contained herein.

6. Procedure

6.1 *Literature*—Literature shall be provided with each LVP marker and shall include, as applicable, the instructions, cautionary statements, and safety tips specified in Section 11.

6.2 *Packaging*—Packaging shall be labeled in a prominent and conspicuous manner in accordance with the provisions of 10.1.

6.3 *Finish*—The exposed edges of all LVP markers shall be smooth and free of sharp edges and burrs.

6.4 *Shipping*:

6.4.1 Each LVP marker shall be shipped in an unloaded and degassed condition.

6.4.2 All LVP markers must shoot at a velocity under 53.34 m/s (175 ft/s) at the time of shipment at SATP.

6.5 *Design*:

6.5.1 All LVP markers intended to be used with removable cylinders shall be able to withstand input pressure of 3000 lb/in.² 207 bar (3000 psi) without catastrophic failure. Leaking in a manner that would not cause injury to the operator shall not constitute failure in accordance with Specification F1750.

6.5.2 A marker’s performance may not be enhanced, including but not limited to increasing the markers’ velocity without the use of tools or disassembly.

6.5.3 All LVP markers shall only operate in semi-automatic or pump mode and may not operate in other discharge modes.

7. Performance Requirements

7.1 *Marker Function*—The cocking or pumping mechanism of a LVP marker shall not cause a marker to discharge unintentionally while a marker is being cocked in accordance with the manufacturer’s instructions. This does not limit the use of “auto-triggers.” Markers shall be a pump or a semi-automatic, or both, as defined in this specification.

7.2 *Disabling Device*—Disabling devices shall be provided on all LVP markers and all such devices shall keep from firing marker whether or not the marker is cocked. All such devices shall be clearly marked to indicate the “safe” and “fire” or “on” and “off” positions in accordance with 3.1.6. All such devices shall be capable of preventing the markers from being discharged when a weight of 13.6 kg (30 lb) is applied to the trigger. Tests shall be conducted in accordance with 8.3.

7.3 *Accidental Discharge*—Markers should not accidentally discharge when exposed testing in accordance with 8.3.

8. Test Methods

8.1 No precision statement on any of the following test methods is available at this time.

8.2 *Disabling Device Test*:

8.2.1 *Significance*—This method determines if the disabling device will withstand a 13.6 kg (30 lb) applied weight without failure, causing the marker to discharge.

8.2.2 *Apparatus*—A trigger weight system having a 13.6 kg ± 0.02 kg (30 lb ± 0.05 lb) weight. Arrange the weight system so that the weights can be picked up by the trigger of the marker with the marker in a vertical position, muzzle up. (A spring gage capable of measuring the trigger force can be used instead of the weight system.)

8.2.3 *Test Specimen*—The test specimen shall consist of a new LVP marker selected in accordance with the manufacturer’s usual quality assurance practices.

8.2.4 Procedure:

8.2.4.1 Conduct the test at SATP.

8.2.4.2 Conduct all tests without LVRM Projectiles in the marker.

8.2.4.3 Place disabling device in “safe” position or the electronic switch in the “off” position.

8.2.4.4 Apply a 13.6 kg (30 lb) load at the center point of the trigger for 30 s with the load applied to the center of the face of the trigger and remove the load.

8.2.4.5 Put disabling device in the “fire” position or the electronic switch in the “on” position. The marker must not discharge as the safety is disengaged.

8.2.4.6 Test the marker for proper trigger and disabling device action.

8.2.4.7 The marker passes the test if it withstands the load applied without causing the marker to discharge during the application of the load and does not discharge upon the disengagement of the disabling device, and the disabling device and trigger function properly after testing.

8.3 Accidental Discharge Test:

8.3.1 Significance—LVP markers should not discharge while their disabling device is disengaged.

8.3.2 Test Specimen—The test specimen shall consist of a new LVP marker, selected in accordance with the manufacturer’s usual quality assurance practices.

8.3.3 Procedure:

8.3.3.1 Conduct the test at SATP.

8.3.3.2 Attach a properly charged propellant source if required in accordance with the manufacturer’s instructions. Test discharge the marker.

8.3.3.3 Leave the marker in the ready to discharge condition.

8.3.3.4 Suspend marker using a sling (see Fig. 2).

8.3.3.5 Place the cocked impact tester (see Fig. 1) against the side of the marker centered on the grip frame directly behind the center point of the trigger with the impact tester firmly affixed to an immobile surface.

8.3.3.6 Release the impact tester and observe if the marker discharges.

8.3.3.7 Repeat by impacting the marker on the following axis:

- (1) 180 degrees to the first impact.
- (2) The front of the barrel aligned with the barrel’s axis.
- (3) The rearmost point of the marker aligned with the barrel’s axis.

8.3.3.8 The marker fails if it discharges on any impact.

8.4 Barrel Blocking Device Requirement:

8.4.1 Significance—All LVP markers that include a barrel must be packaged with a barrel blocking device.

8.4.2 Test Specimen—The test specimen shall consist of a new LVP marker packaged in the manufacturer’s original packaging.

8.4.3 Procedure—Open packaging and inspect for the presence of a barrel blocking device. Any package not containing a barrel blocking device fails this requirement.

8.5 Impact Testing:

8.5.1 Significance—The test is intended to simulate situations in which possible damage can occur by reason of its falling or other impact situations that may occur as a result of

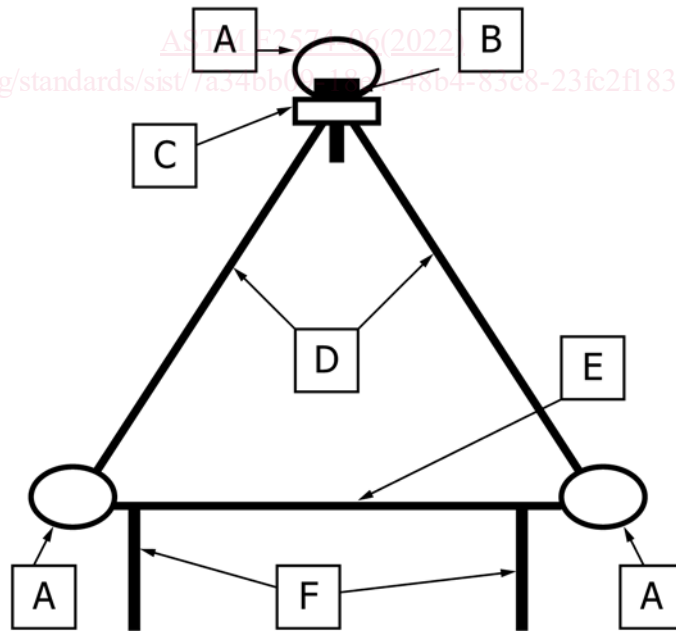

- A. Yoke
- B. Pivot Bolt
- C. Swivel
- D. 91.29 cm (36 in.) Strap or Rope
- E. 60.86 cm (24 in.) aluminum bar with 1.27 cm (0.5 in.) diameter or 1.9 cm (0.75 in.) copper tube
- F. Hook and loop strap able to suspend marker parallel to and 15.21 cm (6 in.) below E

FIG. 2 Sling Example