



Designation: E754 – 80 (Reapproved 2022)

# Standard Test Method for Pullout Resistance of Ties and Anchors Embedded in Masonry Mortar Joints<sup>1</sup>

This standard is issued under the fixed designation E754; the number immediately following the designation indicates the year of original adoption or, in the case of revision, the year of last revision. A number in parentheses indicates the year of last reapproval. A superscript epsilon ( $\epsilon$ ) indicates an editorial change since the last revision or reapproval.

## INTRODUCTION

The attachment of masonry walls to building exteriors has been based largely on experience and professional judgment. Codes and standards requirements relating to the attachment of masonry veneer and nonload-bearing masonry walls generally specify the size and spacing of the fasteners to be provided (ties or anchors) rather than the forces to be resisted. In addition, there are very limited data available on the structural performance of most types of fasteners currently used in masonry construction.

This test method is recommended for determining conservative ultimate pullout values of masonry fasteners under conditions that approach those usually found in the upper courses of masonry wall construction, which experience little or practically no vertical load restraint. Its use is recommended until more comprehensive methods are developed which can evaluate, economically, the capacity of masonry ties and anchors to resist pullout loads, giving due consideration to service parameters such as expanse of surrounding wall area and in-plane dead loads.

## 1. Scope

1.1 This test method provides procedures for determining the ability of individual masonry ties and anchors to resist extraction from a masonry mortar joint.

1.2 Two laboratory testing procedures are provided for use with test specimens which consist of a masonry tie or anchor embedded in mortar between twin stack-bonded masonry units.

1.2.1 *Procedure A*—For use with small (brick-size) masonry units.

1.2.2 *Procedure B*—For use with large (block-size) masonry units.

1.3 The values stated in inch-pound units are to be regarded as standard. The values given in parentheses are mathematical conversions to SI units that are provided for information only and are not considered standard.

1.4 *This standard does not purport to address the safety concerns, if any, associated with its use. It is the responsibility of the user of this standard to establish appropriate safety, health, and environmental practices and determine the applicability of regulatory limitations prior to use.*

<sup>1</sup> This test method is under the jurisdiction of ASTM Committee E06 on Performance of Buildings and is the direct responsibility of Subcommittee E06.13 on Structural Performance of Connections in Building Construction.

Current edition approved Oct. 1, 2022. Published October 2022. Originally approved in 1980. Last previous edition approved in 2014 as E754 – 80 (2014) <sup>$\epsilon$ 1</sup>. DOI: 10.1520/E0754-80R22.

1.5 *This international standard was developed in accordance with internationally recognized principles on standardization established in the Decision on Principles for the Development of International Standards, Guides and Recommendations issued by the World Trade Organization Technical Barriers to Trade (TBT) Committee.*

## 2. Referenced Documents

2.1 *ASTM Standards:*<sup>2</sup>

C67/C67M Test Methods for Sampling and Testing Brick and Structural Clay Tile

C109/C109M Test Method for Compressive Strength of Hydraulic Cement Mortars (Using 2-in. or [50 mm] Cube Specimens)

C140/C140M Test Methods for Sampling and Testing Concrete Masonry Units and Related Units

C144 Specification for Aggregate for Masonry Mortar

C270 Specification for Mortar for Unit Masonry

E4 Practices for Force Calibration and Verification of Testing Machines

E6 Terminology Relating to Methods of Mechanical Testing

E171/E171M Practice for Conditioning and Testing Flexible Barrier Packaging

<sup>2</sup> For referenced ASTM standards, visit the ASTM website, [www.astm.org](http://www.astm.org), or contact ASTM Customer Service at [service@astm.org](mailto:service@astm.org). For *Annual Book of ASTM Standards* volume information, refer to the standard's Document Summary page on the ASTM website.



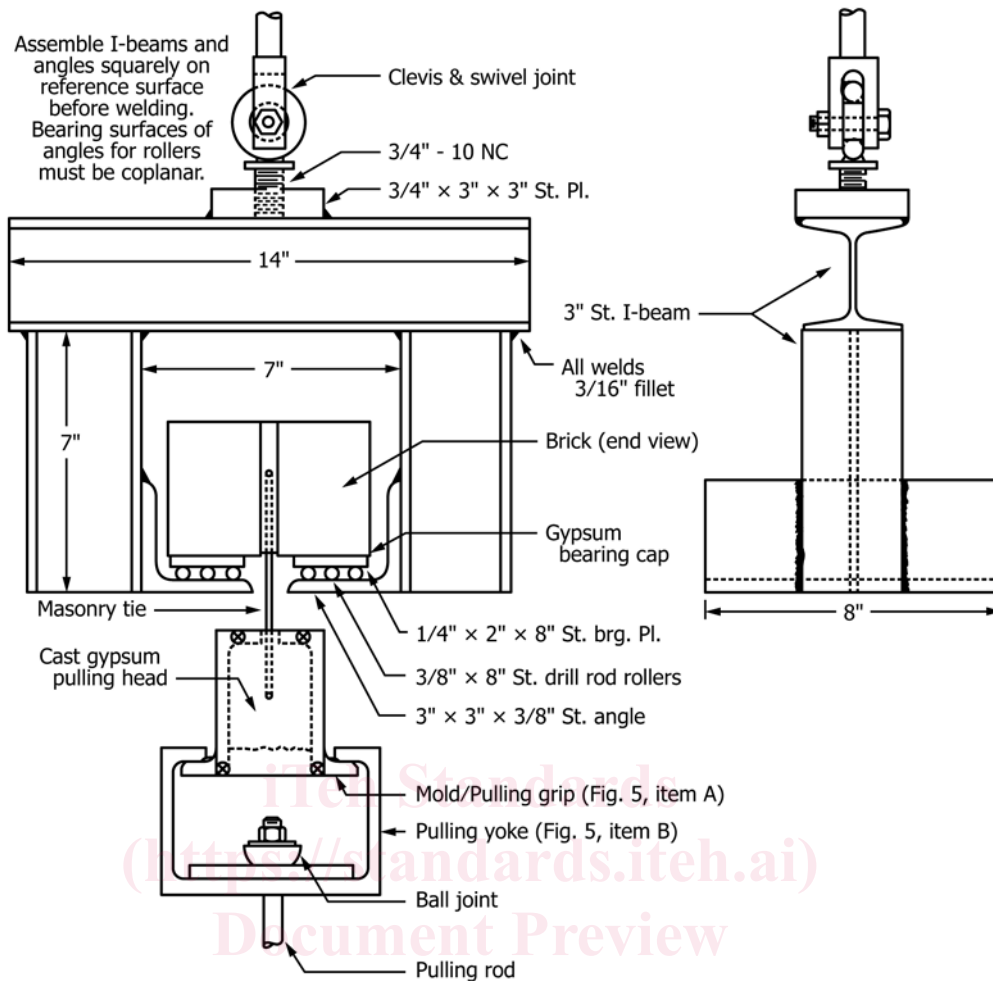

NOTE 1—1 in. = 25.4 mm.

FIG. 2 Procedure A Apparatus and Setup

<https://standards.iteh.ai/catalog/standards/sist/c61d5380-a3c2-4222-a835-f7453f0798d/astm-e754-802022>

specimens may be needed depending on the variability of the masonry constituents. If necessary, determine suitable statistical parameters to evaluate the composite variability and to select the number of specimens needed for obtaining a given minimum precision in determining the capacity of the fastener.

**7.2 Sampling and Testing of Masonry Units**—Select representative masonry units and test according to applicable standard test methods (Test Methods **C67/C67M** and **C140/C140M**) to determine basic properties.

**7.3 Sampling and Testing of Mortar**—Use mortar that is representative of that specified for the intended construction; or, for comparative research data, select one of the types of mortar specified in Specification **C270**. Determine the compressive strength of the mortar in accordance with Test Method **C109/C109M** except that the sand shall conform to Specification **C144**. Allow the mortar to cure undisturbed for 24 h in the molds. Release the cubes and store them in the same atmosphere as the pullout test specimens, as specified in **7.5**. Determine and record the 28-day compressive strength of the

mortar (at least three cubes for each set of five pullout specimens), and the sieve analysis of the sand used.

**7.4 Fabrication**—Construct at least five specimens for a given combination of variables. Make each specimen a singlewythe (one-tier), stack-bonded, two-unit prism containing one tie or anchor. Unless otherwise specified, make the single mortar joint  $\frac{3}{8}$  in. (10 mm) thick. Embed the fastener as required for its proper use at the midlength of the masonry units. (Unless otherwise specified, use a full bed of mortar on solid masonry units (without furrowing the mortar bed), and fully bed the face shells of hollow units.) Strike the mortar joint flush with the faces of the masonry units without tooling. Mark the lower masonry unit for future reference (**8.4.2**).

**7.5 Curing and Handling:**

**7.5.1** Cure all pullout specimens and corresponding mortar cube specimens for 28 days. Unless other conditions are specified, cure and test all specimens in laboratory air maintained at 73 °F (23 °C) and 50 % relative humidity as provided by Practice **E171/E171M**.

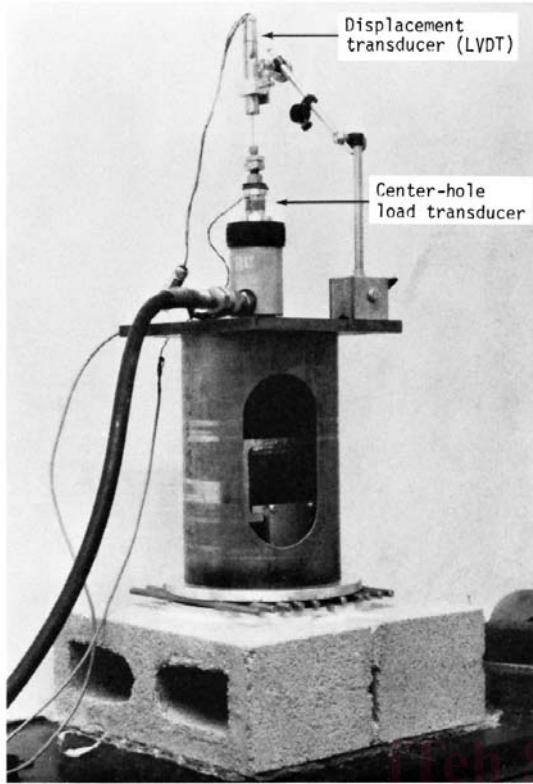

FIG. 3 Procedure B Apparatus and Setup

7.5.2 To prevent accidental failure of mortar bond in the joints, do not disturb the pullout specimens for at least 14 days. After that time they may be handled with care in order to complete capping operations before testing at a specimen age of 28 days.

## 8. Procedure

8.1 *Gypsum Capping Test Specimens*—To provide a smooth bearing surface on the fastener side of the fabricated specimen, apply a gypsum plaster cap. Taking care to prevent the gypsum paste from bridging the mortar joint, cap the masonry unit faces beyond which the fastener protrudes, in the same general way described under “Gypsum Plaster Capping” of Test Methods C67/C67M or C140/C140M, except:

8.1.1 *Procedure A Specimens*—For a casting surface on which to spread the gypsum plaster, use the notched metal capping plate (Fig. 5) elevated on supports that are high enough to accommodate the protruding fastener in a hanging position.

8.1.2 *Procedure B Specimens*—Cap specimens made of block-size units in an inverted position with the fastener side up. To cap the test load-bearing surface of these specimens, bed the half-ring plates (two halves held coplanar by attachment to a whole-ring plate: Fig. 6) in a thin coat of gypsum paste that has been spread on the masonry unit faces on the side toward the fastener.

8.2 *Casting the Gypsum Pulling Heads*—In order to grip the end of the fastener with the pulling apparatus, cast a slug of high-strength gypsum around the protruding end in an upright

position (for example, Fig. 6) using the four-piece mold shown in Fig. 7 (Part A). For casting, support the assembled mold so as to enclose the maximum available length of the fastener, but leaving exposed the necessary length to accommodate the pulling apparatus when testing (Fig. 2 and Fig. 4). The mold must be coaxial with the fastener. If necessary, mechanical anchoring of the fastener in the gypsum casting can be increased by bending the end of the fastener, or by attaching (for example, by welding) a small suitable auxiliary anchor. Coat the inner surfaces of the mold with a light film of oil, and cast the head using high-strength capping gypsum. Before removing the mold after the gypsum has set, mark the head to identify its position relative to the mold; this will make possible a matching fit when reassembling the mold/jig on the gypsum pulling head for testing. Casting must be completed in time to allow the gypsum to attain sufficient strength for testing the pullout specimens at an age of 28 days.

### 8.3 Pullout Testing:

8.3.1 *Pulling-Head Grip*—In both Procedures A and B, reassemble the mold/pulling jig on the gypsum head of the test specimen oriented so that originally matching surfaces are in contact.

8.3.2 *Procedure A (Small, Masonry-Unit Specimens)*—Center the specimen in the auxiliary pulling apparatus and universal testing machine as shown in Fig. 1 and Fig. 2. The specimen must also rest symmetrically on the bearing plates and rollers.

8.3.3 *Procedure B (Large, Masonry-Unit Specimens)*—Place the specimen on a sponge rubber mat and assemble the special pulling apparatus centrally on the specimen, positioning the roller bearings parallel to the mortar joint (Fig. 3 and Fig. 4).

NOTE 1—Detach the two half-ring plates which were used for capping from the whole-ring plate and reinstall on the plaster caps; these three plates serve as bearing plates for the rollers between them (Fig. 3 and Fig. 4).

8.3.4 *Gage Mounting*—Mount the displacement measuring gage to detect the movement of the end of the pulling rod relative to the masonry (Figs. 1-4). This movement is taken to be equal to the displacement of the fastener under load, relative to the surrounding masonry.

NOTE 2—For the magnitude of the loads and displacements accompanying these test conditions, it is not likely that elongation of the apparatus will be significant. However, if necessary, such measurements can be corrected by calibration-test data for an equivalent setup using a rigid mock-up (steel block and rod) in place of the masonry and fastener specimen.

8.3.5 *Loading*—Apply an initial load to the specimen of about 5 % of the fastener’s estimated maximum pullout capacity in order to bring all elements of the pulling apparatus into tensile contact. The initial load value may be adjusted for subsequent tests of replicate specimens, depending on the results of preceding tests. Set the displacement measuring gage to zero while maintaining the initial load constant. Continue to apply increasing load at the rate of 20 % of the estimated fastener maximum capacity per minute until failure occurs. Record at least eight intermediate load/displacement measurements in addition to the initial and maximum values at approximately equal load intervals.

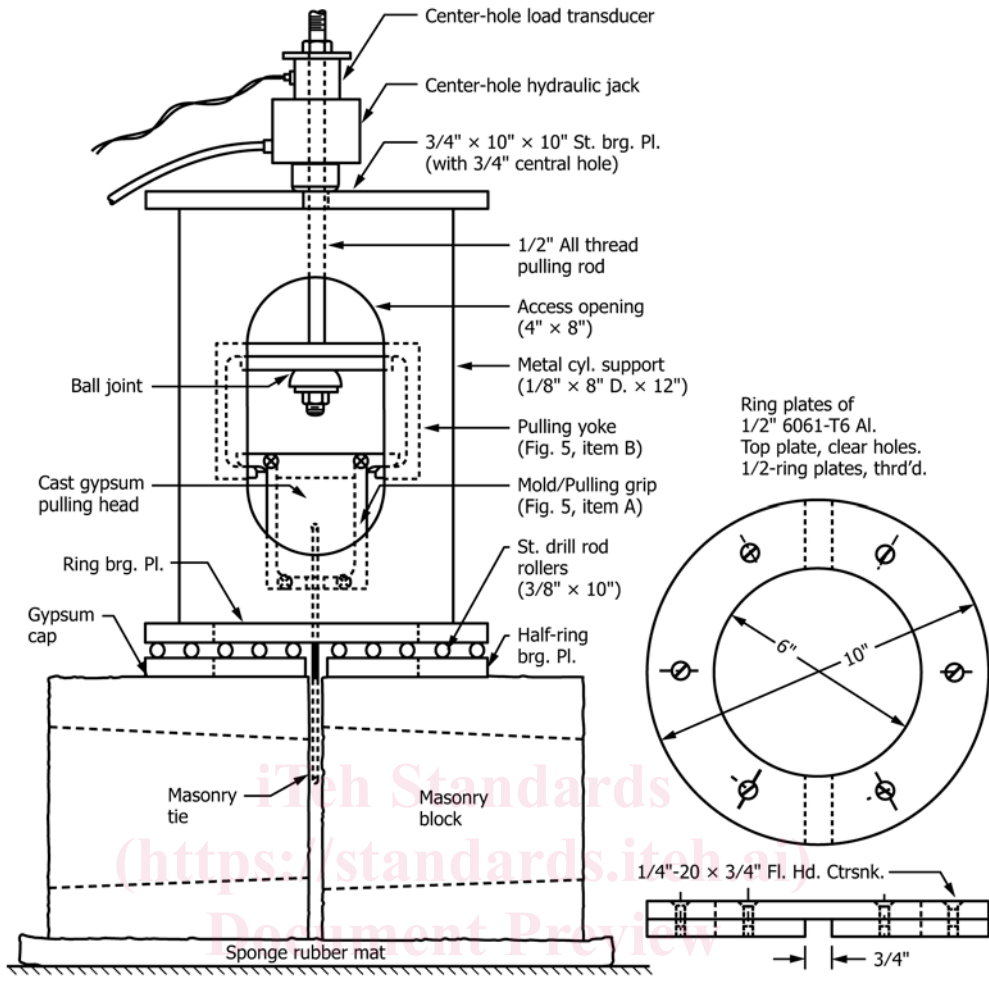

(b)

NOTE 1—1 in. = 25.4 mm.

FIG. 4 Procedure B Apparatus and Setup

<https://standards.iteh.ai/catalog/standards/sist/c61d5380-a5c2-4222-a835-f7453f0798d/astm-e754-802022>

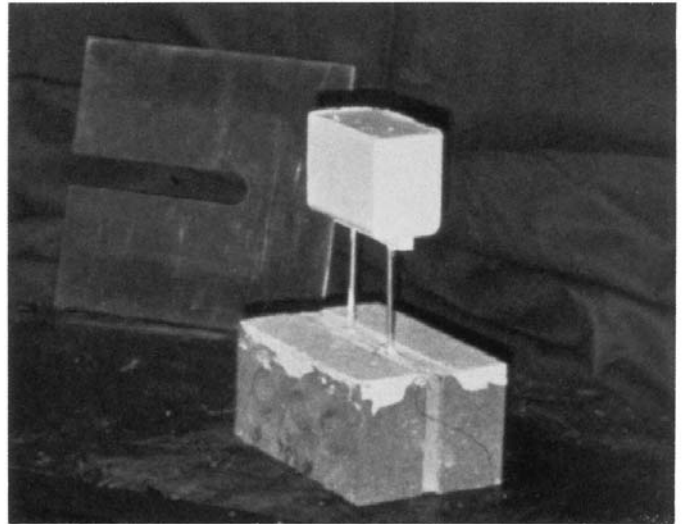
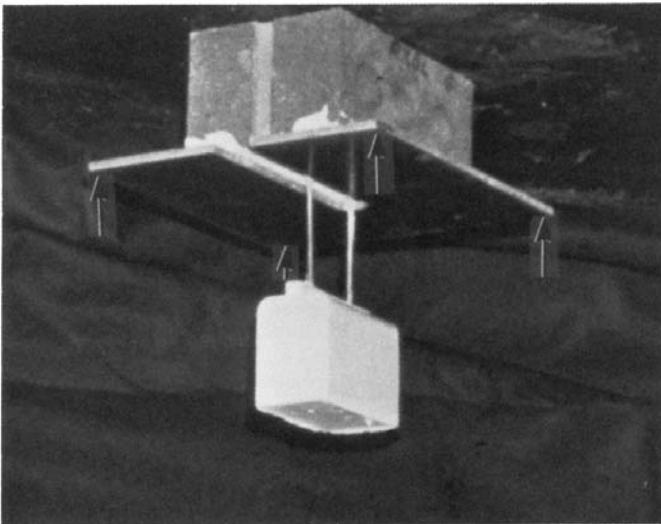

FIG. 5 Notched Metal Plate Used for Capping Specimens in Procedure A