



Designation: ~~C1921/C1921M – 21~~ C1921/C1921M – 22

Standard Test Method for Comparative Impact Testing of Gypsum Panel Outside 90° Corner Systems¹

This standard is issued under the fixed designation C1921/C1921M; the number immediately following the designation indicates the year of original adoption or, in the case of revision, the year of last revision. A number in parentheses indicates the year of last reappraisal. A superscript epsilon (ϵ) indicates an editorial change since the last revision or reappraisal.

1. Scope

1.1 This test method details the method for a laboratory-based evaluation of aesthetic damage caused to a non-structural gypsum panel outside 90° corner system when impacted by a hard body. This test's purpose is to provide comparative information on different gypsum panel corner systems to demonstrate aesthetic robustness and durability by minimizing initial damage.

1.2 There is no known ISO equivalent to this standard.

1.3 *Units*—The values stated in either SI units or inch-pound units are to be regarded separately as standard. The values stated in each system are not necessarily exact equivalents; therefore, to ensure conformance with the standard, each system shall be used independently of the other, and values from the two systems shall not be combined.

1.4 *This standard does not purport to address all of the safety concerns, if any, associated with its use. It is the responsibility of the user of this standard to establish appropriate safety, health, and environmental practices and determine the applicability of regulatory limitations prior to use.*

1.5 *This international standard was developed in accordance with internationally recognized principles on standardization established in the Decision on Principles for the Development of International Standards, Guides and Recommendations issued by the World Trade Organization Technical Barriers to Trade (TBT) Committee.*

2. Referenced Documents

2.1 ASTM Standards:²

[C11 Terminology Relating to Gypsum and Related Building Materials and Systems](#)

[C475/C475M Specification for Joint Compound and Joint Tape for Finishing Gypsum Board](#)

[C645 Specification for Nonstructural Steel Framing Members](#)

[C754 Specification for Installation of Steel Framing Members to Receive Screw-Attached Gypsum Panel Products](#)

[C954 Specification for Steel Drill Screws for the Application of Gypsum Panel Products or Metal Plaster Bases to Steel Studs from 0.033 in. \(0.84 mm\) to 0.112 in. \(2.84 mm\) in Thickness](#)

[C1002 Specification for Steel Self-Piercing Tapping Screws for Application of Gypsum Panel Products or Metal Plaster Bases to Wood Studs or Steel Studs](#)

[C1047 Specification for Accessories for Gypsum Wallboard and Gypsum Veneer Base](#)

[C1396/C1396M Specification for Gypsum Board](#)

¹ This test method is under the jurisdiction of ASTM Committee C11 on Gypsum and Related Building Materials and Systems and is the direct responsibility of Subcommittee C11.02 on Specifications and Test Methods for Accessories and Related Products.

Current edition approved Dec. 1, 2021/Oct. 1, 2022. Published December 2021/October 2022. Originally approved in 2021. Last previous edition approved in 2021 as C1921/C1921M – 21. DOI: [10.1520/C1921-21](https://doi.org/10.1520/C1921-21); [10.1520/C1921_C1921M-22](https://doi.org/10.1520/C1921_C1921M-22).

² For referenced ASTM standards, visit the ASTM website, www.astm.org, or contact ASTM Customer Service at service@astm.org. For *Annual Book of ASTM Standards* volume information, refer to the standard's Document Summary page on the ASTM website.

F879 Specification for Stainless Steel Socket Button and Flat Countersunk Head Cap Screws

2.2 *AISI Standard:*

S220 North American Standard for Cold-formed Steel Framing – non-structural members³

2.3 *Eurogypsum Standard:*

Drywall Jointing & Finishing Surface Quality Level Classifications⁴

2.4 *Gypsum Association Standards:*

GA-214 Recommended Levels of Finish: Gypsum Board, Glass Mat & Fiber-Reinforced Gypsum Panels⁵

GA-216 Application and Finishing of Gypsum Panel Products⁵

3. Terminology

3.1 *Definitions*—Definitions shall be in accordance with Terminology C11 unless otherwise indicated.

3.2 *Definitions of Terms Specific to This Standard:*

3.2.1 *corner attachment method, n*—as per the manufacturer’s instructions and may be specific to the type of corner protection, the most common methods of which include: embedding, nailing, clinching, and stapling.

3.2.2 *corner protection, n*—product designed to provide some additional protection to a gypsum panel partition wall corner structure, which may be in stick/trim or roll format.

3.2.3 *double-layer, adj*—partition corner test specimen comprised of a two-layer gypsum panel system (see Fig. 1).

3.2.4 *gypsum panel outside 90° corner system, n*—describes all components that make up a 90° corner of a partition wall commonly comprised of gypsum panel, studs, fasteners, joint compound, corner protection, potentially joint tape, and, also, the method of corner protection attachment.

3.2.5 *hollow corner, n*—non-standard, but commonly used, corner configuration that has no apex (see Fig. 2 and Fig. 3).

3.2.6 *mitered corner, n*—gypsum panel corner formed by cutting a “v-shaped” channel through the reverse of the panel, leaving the paper face liner intact; the panel is then folded and glued to form a 90° corner (see Appendix X1 and Fig. 4).

3.2.7 *90° degree corners, n*—corners that measure approximately outside 90 degrees.

3.2.8 *overlapped corner, n*—standardized configuration for a gypsum panel corner in accordance with GA-216.

3.2.9 *single-layer, adj*—partition corner test specimen comprised of a one-layer gypsum panel system (see Fig. 4).

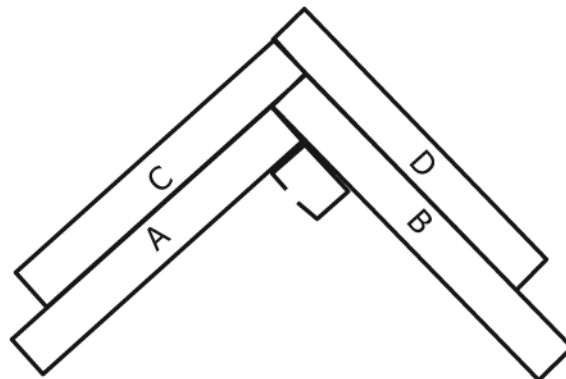

FIG. 1 Double-layer Corner (with Steel Stud)

³ Available from the American Iron and Steel Institute, 25 Massachusetts Ave., NW, Suite 800, Washington, DC 20001, shop.steel.org.

⁴ Available from eurogypsum.org.

⁵ Available from the Gypsum Association, 962 Wayne Ave., Suite 620, Silver Spring, MD 20910, gypsum.org.

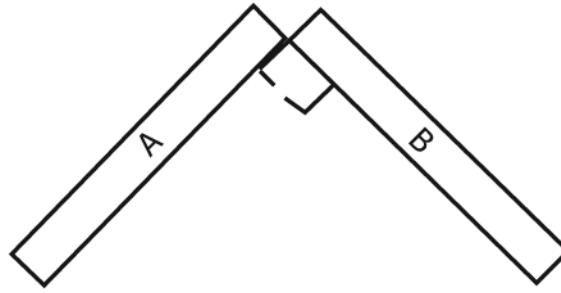

FIG. 2 Single-layer Hollow Corner with Steel Stud

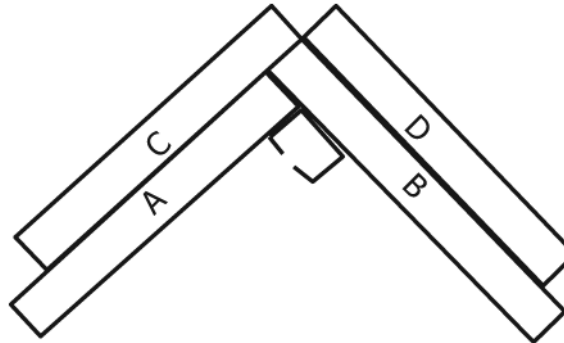

FIG. 3 Double-layer Hollow Corner with Steel Stud

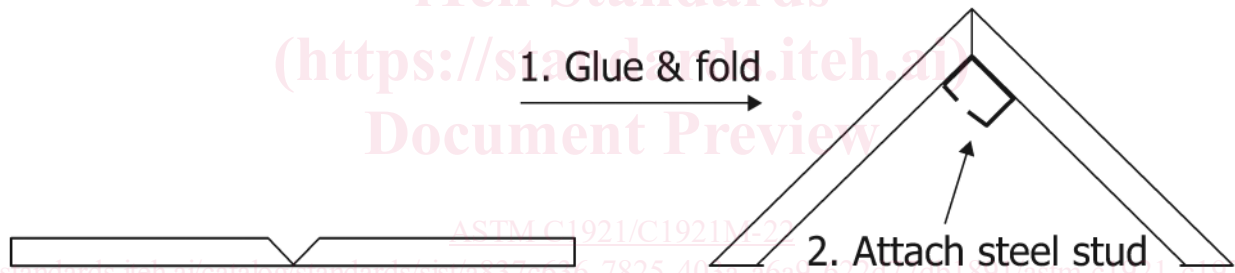

FIG. 4 Mitred Corner

4. Summary of Test Method

4.1 The principle of this test method is to provide characterization and data for gypsum panel outside 90° corner systems when subject to an impact of defined energy, specifically at the apex of the corner. This methodology allows comparisons to be drawn between different systems.

4.2 The system is comprised of a cornerbead conforming to Specification C1047, a gypsum panel conforming to Specification C1396/C1396M, joint compound conforming to Specification C475/C475M, and related fastening products conforming to Specification C754, C954/C1002 (depending upon steel stud thickness), and AISI S220.

5. Significance and Use

5.1 This test method provides a repeatable methodology for evaluating outside 90° corner systems.

6. Interferences

6.1 The build consistency of the test specimens greatly influences the result. Creating a fixture to support the sample for application of the corner protection provides greater consistency. Batch details of all components should be recorded for traceability.

7. Apparatus

7.1 Nine cylindrical weights of the same outer dimensions but of varying mass are used (Fig. 5). Weights shall be made from stainless steel or other similar durable material. Weights shall be ± 10 g [± 0.022 lb] of the target weight. The point at which the weight will contact the sample shall be 50 mm [2 in. $\pm 5/64$ in.] in diameter.

7.2 The only factors that shall be adhered to are the dimensions of the striking end of the weights (Table 1), the mass of the weights, and the drop heights (Table 2). Other dimensions pertaining to the drop pipe and weights such as the length of the pipe, pipe diameter, length of the weight, and so forth are suggestions only and should be determined by the user.

7.3 Cylindrical seamless steel pipe of 88.9 mm [$3\frac{1}{2}$ in.] outer diameter (NPS3; Schedule 30) and 1600 mm ± 50 mm [63 in. ± 2 in.] in length, with three predetermined “drop points” for the aforementioned weights at 500 mm ± 5 mm, 1000 mm ± 5 mm, and 1500 mm ± 5 mm [~~20 in.~~ 19.69 in. $\pm 13/64$ in., ~~39 in.~~ 39.37 in. $\pm 13/64$ in., and ~~59 in.~~ 59.06 in. $\pm 13/64$ in.] from the center of the release pin to the base of the pipe (± 5 mm [$13/64$ in.]) (Fig. 6). Each drop level has an access point in the pipe where the weight is positioned on top of a steel release pin before testing. The pipe is mounted vertically and is positioned directly above the center of the sample.

7.4 Care shall be taken to ensure that the weight falls freely; it shall not “chatter” down the pipe.

7.5 *Steel Release Pin*—See Fig. 7.

7.6 The steel sample support doubles as a fixture for sample preparation (see Figs. 8-10).

7.7 *Calibrated Dial Test Indicator of Resolution 0.01 mm [0.0005 in.] and travel of 0 mm to 25 mm [0 in. to 1 in.]*—A standard or tapered point are both suitable with a contact point of 0.2 mm [$1/64$ in.]. The indicator should be supported in a suitable bracket so as to straddle the impact damage and sit comfortably on the apex of the corner.

8. Materials

8.1 Gypsum panel, as defined in Specification C1396/C1396M.

8.2 Galvanized steel stud as defined in Specifications C645 and AISI S220. The stud used shall fit into the aperture of the support. Commonly used sizes would include 48 mm/ 0.5 mm [$1\frac{5}{8}$ in./ 18 mil] steel studs.

8.3 *Screws*—Screws shall be compliant with Specification C1002 or C954 depending on steel stud thickness.

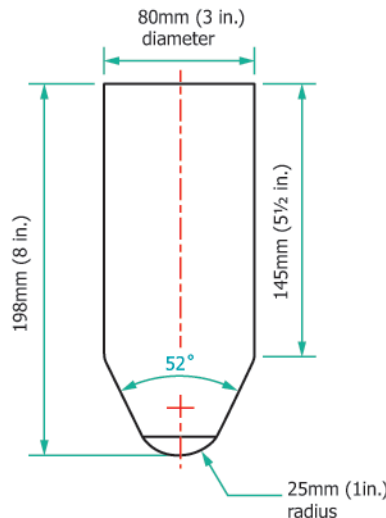

FIG. 5 Weight Outer Dimensions



TABLE 1 Weight Dimensions

	mm [in.]
Diameter	80 ± 0.5 [3 ± 1/64]
Total length	198 ± 2 [8 ± 5/64]
Length of cylinder section	145 ± 2 [5 1/2 ± 5/64]
Radius of striking end (mandatory)	25 ± 1 [1 ± 3/64]

NOTE 1—The weights and drop heights shown have been calculated in order to achieve impact energies from 5 J to 100 J in 5 J increments. Thus it is a more regular scale than the ft.lbs conversion.

TABLE 2 Matrix for Test Selection: Drop Height and Drop Weight Settings (Mandatory)

Energy imparted to sample in Joules, metric weights and heights				
Drop height, millimetres				
	500	1000	1500	
Weight, kg	1	5	10	15
	3	15	30	45
	4	20	40	60
	5	25	50	75
	5.5	25	55	80
	5.75	30	55	85
	6	30	60	90
	6.5	30	65	95
7	35	70	100	
Energy imparted to sample in ft-lb, Imperial weights and heights				
Drop height, inches				
	19.50	39.50	59.00	
	19.69	39.37	59.06	
Weight, lbs	2.2	4	7	11
	6.6	11	22	32
	8.8	14	29	43
	11.0	18	36	54
	12.0	20	40	59
	12.7	21	41	62
	13.2	22	43	65
	14.3	23	47	70
15.4	25	50	76	

TABLE 3 Weights Required (Mandatory)

kg	lb
1	2.2
3	6.6
4	8.8
5	11.0
5.5	12.0
5.75	12.7
6	13.2
6.5	14.3
7	15.4

8.4 *Joint Compound*—Drying type or setting-type compound. The setting compound should be mixed as specified on the product packaging. The compound shall be compliant with Specification **C475/C475M**.

8.5 *Corner Protection*—Corner tape or rigid corner trim (metal, various plastics, or laminate construction) as defined in Specification **C1047**.

8.6 *Materials for the Attachment of the Corner Trim to the Gypsum Panel Corner*—Determined by corner manufacturers installation guidelines.

8.7 *Glue*—Solvent-based adhesive appropriate for gypsum panels.

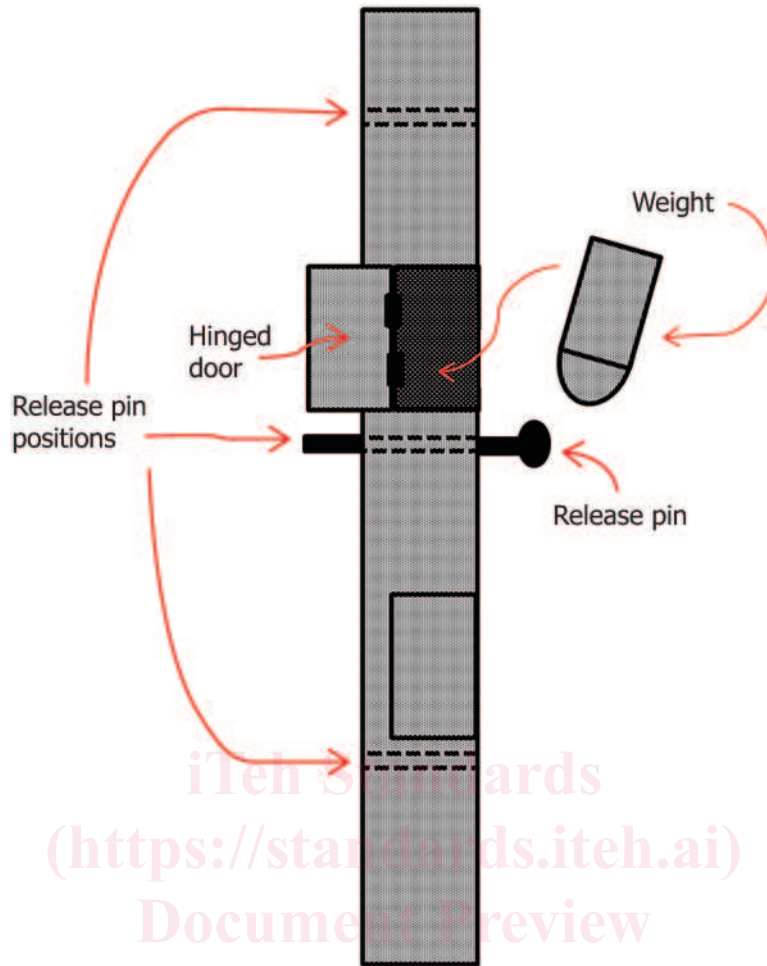

FIG. 6 Pipe Apparatus

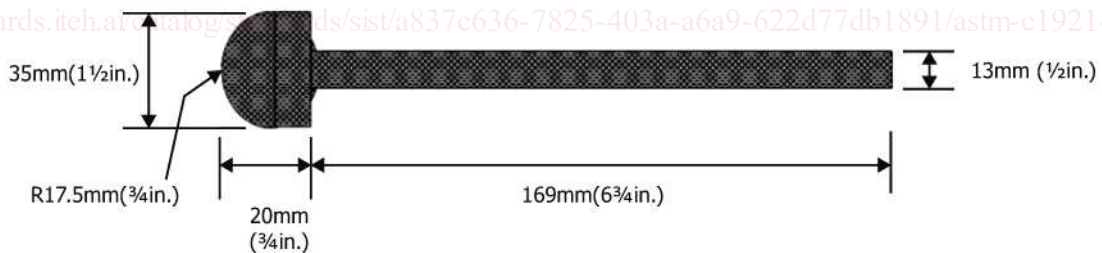

FIG. 7 Steel Release Pin

9. Sampling, Test Specimens, and Test Units

9.1 Single-layer Corner Sample:

9.1.1 Cut two pieces of gypsum panel: Piece A: 320 mm × 200 mm [12½ in. × 8 in.] and Piece B: 320 mm × 200 mm [12½ in. × 8 in.] + thickness of the gypsum panel.

9.1.2 Cut steel stud to 320 mm [12½ in.] in length.

9.1.3 Attach the steel stud to gypsum panel Piece A next to the long (320 mm [12½ in.]) edge on the back side of the panel. Fix through the stud using two screws approximately 10 mm [3/8 in.] in from each edge.

9.1.4 Position gypsum panel Piece B so it overlaps gypsum panel Piece A to create a flush corner. Fix with two screws approximately 10 mm [3/8 in.] in from each edge of gypsum panel Piece B.

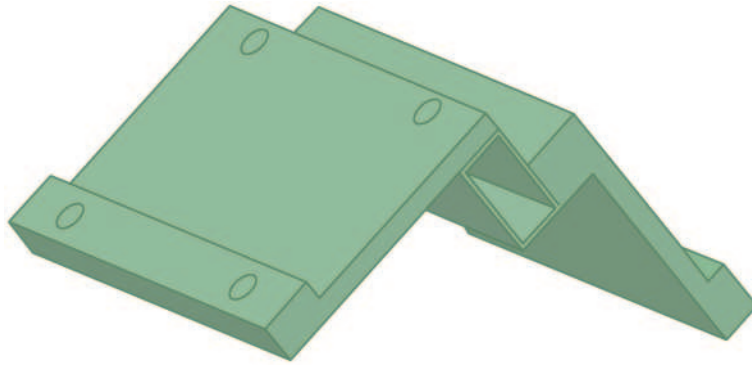
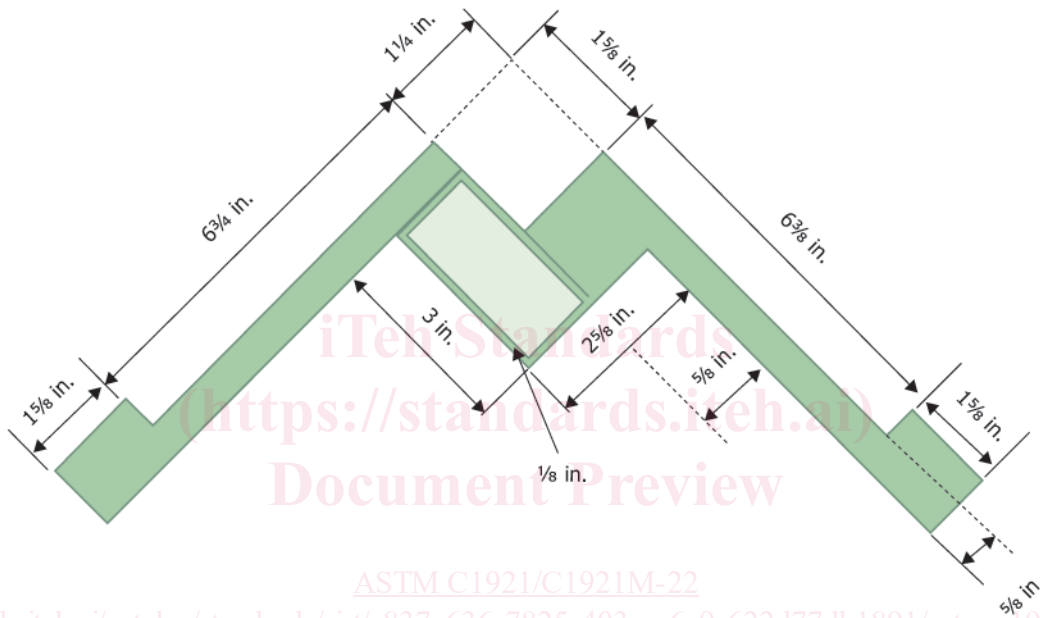

FIG. 8 Sample Support



NOTE 1—The structure is held together with eight M8 or $\frac{5}{16}$ in. stainless steel socket flat countersunk cap screws and mating A2/18-8 SS nuts.

FIG. 9 Steel Sample Support, of Plate Thickness $\frac{5}{8}$ in. and $\frac{1}{8}$ in.

9.1.5 Cut corner protection to 320 mm [12½ in.] in length.

9.1.6 Attach the corner protection as directed by the manufacturer’s instructions and coat the sample with your compound of choice (two coats may be required).

9.1.7 Once dry, finish to Level 3 (as defined in GA-214) or Q2 (as defined in Eurogypsum Drywall Jointing & Finishing Surface Quality Level Classifications).

9.1.8 Samples should be allowed to dry for at least three days and then conditioned for at least 24 h before testing ($23\text{ }^{\circ}\text{C} \pm 2\text{ }^{\circ}\text{C}$ [$72\text{ }^{\circ}\text{F} \pm 3\text{ }^{\circ}\text{F}$] and $50\% \pm 5\%$ relative humidity).

9.2 *Double-layer Corner Sample:*

9.2.1 Cut four pieces of gypsum panel: Piece A: 320 mm × 200 mm [12½ in. × 8 in.], Piece B: 320 mm × 200 mm [12½ in. × 8 in.] + thickness of the panel, Piece C: 320 mm × 200 mm [12½ in. × 8 in.], and Piece D: 320 mm × 200 mm [12½ in. × 8 in.] + thickness of the panel.

9.2.2 Cut steel stud to 320 mm [12½ in.] in length.