



Standard Specification for Gauge Piping Assemblies¹

This standard is issued under the fixed designation F721; the number immediately following the designation indicates the year of original adoption or, in the case of revision, the year of last revision. A number in parentheses indicates the year of last reapproval. A superscript epsilon (ϵ) indicates an editorial change since the last revision or reapproval.

This standard has been approved for use by agencies of the U.S. Department of Defense.

1. Scope

1.1 This specification covers details of gauge piping assemblies for pressure gauges with optional provisions for additional gauges, pressure switches, transmitters, and so forth, for use with steam, steam drains, feed water, condensate, fresh water, salt water, compressed air, fuel oil, and lubricating oil systems.

1.2 The values stated in inch-pound units are to be regarded as standard. The values given in parentheses are mathematical conversions to SI units that are provided for information only and are not considered standard.

1.3 *This international standard was developed in accordance with internationally recognized principles on standardization established in the Decision on Principles for the Development of International Standards, Guides and Recommendations issued by the World Trade Organization Technical Barriers to Trade (TBT) Committee.*

2. Referenced Documents

2.1 ASTM Standards:²

- A105/A105M Specification for Carbon Steel Forgings for Piping Applications
- A106/A106M Specification for Seamless Carbon Steel Pipe for High-Temperature Service
- A108 Specification for Steel Bar, Carbon and Alloy, Cold-Finished
- A182/A182M Specification for Forged or Rolled Alloy and Stainless Steel Pipe Flanges, Forged Fittings, and Valves and Parts for High-Temperature Service
- A276 Specification for Stainless Steel Bars and Shapes
- A335/A335M Specification for Seamless Ferritic Alloy-Steel Pipe for High-Temperature Service

- A576 Specification for Steel Bars, Carbon, Hot-Wrought, Special Quality
- B16/B16M Specification for Free-Cutting Brass Rod, Bar and Shapes for Use in Screw Machines
- B61 Specification for Steam or Valve Bronze Castings
- B62 Specification for Composition Bronze or Ounce Metal Castings
- B75 Specification for Seamless Copper Tube (Metric) B0075_B0075M
- B124/B124M Specification for Copper and Copper Alloy Forging Rod, Bar, and Shapes
- B453/B453M Specification for Copper-Zinc-Lead Alloy (Leaded-Brass) Rod, Bar, and Shapes
- B466/B466M Specification for Seamless Copper-Nickel Pipe and Tube

2.2 ANSI Standards:³

- B16.11 Forged Steel Fittings, Socket Weld, and Threaded
- B16.15 Cast Bronze Threaded Fittings

2.3 SAE International:⁴

- AMS-QQ-S-763 Steel, Corrosion Resistant, Bars, Wire, Shapes, and Forgings

3. List of Assemblies

3.1 This specification incorporates 13 gauge piping assemblies as described in **Table 1**.

4. General Requirements and Guidelines

4.1 **Fig. 1** shows a typical piping assembly for bottom-connected gauges and **Fig. 2** a typical piping assembly for back-connected gauges.

4.2 A siphon shall be used as shown in all gauge applications for steam systems to maintain a protective water seal between the gauge and the steam supply.

4.3 Each assembly includes a test connection beyond the gauge valve which consists of a tee with a 1/4-in. NPT threaded plug in the branch. The plug is removable for the purpose of installing a test gauge for calibration. As an alternative, a gauge

¹ This specification is under the jurisdiction of ASTM Committee F25 on Ships and Marine Technology and is the direct responsibility of Subcommittee F25.11 on Machinery and Piping Systems.

Current edition approved Oct. 1, 2022. Published October 2022. Originally approved in 1981. Last previous edition approved in 2018 as F721 – 18. DOI: 10.1520/F0721-18R22.

² For referenced ASTM standards, visit the ASTM website, www.astm.org, or contact ASTM Customer Service at service@astm.org. For *Annual Book of ASTM Standards* volume information, refer to the standard's Document Summary page on the ASTM website.

³ Available from American National Standards Institute (ANSI), 25 W. 43rd St., 4th Floor, New York, NY 10036.

⁴ Available from SAE International (SAE), 400 Commonwealth Dr., Warrendale, PA 15096, <http://www.sae.org>.

TABLE 1 Gauge Piping Assemblies^{A,B}

Assembly No.	Service	Maximum Pressure, psi (kPa)	Maximum Temperature, °F (°C)
1	Superheated steam	1125 (7757)	960 (516)
2	High-pressure desuperheated steam and high-pressure extractions	1100 (7584)	580 (304)
3	Low-pressure extractions, gland seal, auxiliary exhaust, and 150-psig (1034-MPa) steam	900 (6205)	563 (295)
4	Low-pressure steam	125 (861)	353 (178)
5	Boiler feed discharge	1500 (10 342)	450 (232)
6	Feed suction and condensate	165 (1138)	300 (149)
7	Compressed air above 165 psi (1.14 MPa)	900 (6205)	563 (295)
8	Compressed air	165 (1138)	300 (149)
9	Fresh and potable water	200 (1379)	150 (66)
10	Main and auxiliary salt water circulating, salt water service, and wet firemain	200 (1379)	150 (66)
11	Dry firemain and deck washdown	200 (1379)	150 (66)
12	Fuel oil and lube oil	900 (6205)	250 (121)
13	Diesel oil	900 (6205)	563 (295)

^A For typical piping assemblies see Fig. 1 and Fig. 2.

^B For materials required see Table 2 and Table 3.

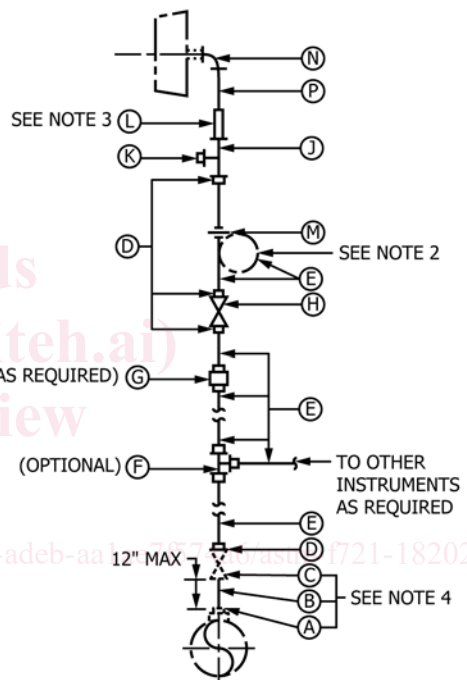
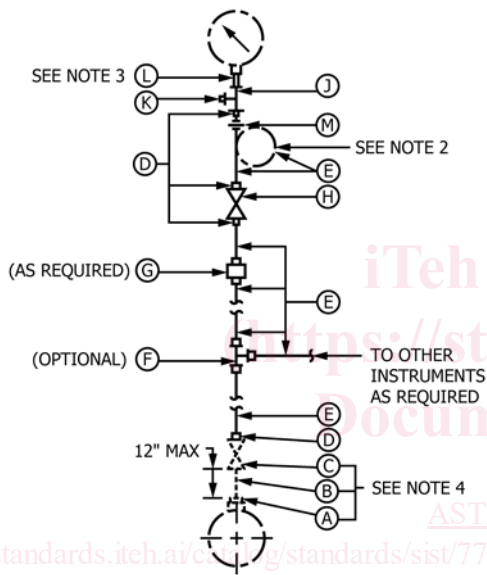

NOTE 1—For material identification see Table 3.

NOTE 2—Use siphon for Assemblies 1 through 4.

NOTE 3—For pulsation dampener requirements see 4.6 and Table 3.

NOTE 4—Piping through the root valve is normally detailed on the piping arrangement drawings but is shown here as an aid in establishing material requirements.

FIG. 1 Typical Piping Assembly for Bottom-Connected Gauges

valve that incorporates a built-in test connection integral with the valve may be substituted for the gauge valve and test tee.

4.4 Root connections should be kept to a minimum by connecting other instruments at the tee between the root and gauge valves. There is no limit to the number of dead-end-type instruments that can be served from a single root connection. However, each instrument should have its own shutoff valve and, if desired, a test tee may be fitted at each instrument.

4.5 Two shutoff valves are generally used in each assembly, a root valve and a gauge cutout valve. The gauge valve may be eliminated and a single shutoff valve may serve as both a root and gauge valve provided the gauge is within 6 ft (1.8 m) of the root connection and readily accessible and the single shutoff valve is fitted within 12 in. (300 mm) of the root connection.

NOTE 1—For material identification see Table 3.

NOTE 2—Use siphon for Assemblies 1 through 4.

NOTE 3—For pulsation dampener requirements see 4.6 and Table 3.

NOTE 4—Piping through the root valve is normally detailed on the piping arrangement drawings but is shown here as an aid in establishing material requirements.

FIG. 2 Typical Piping Assembly for Back-Connected Gauges

4.6 Pulsation dampeners are shown for certain assemblies between the test tee and gauge and should be used in other assemblies in which the gauge may be subjected to pulsating pressures, as from a reciprocating pump, air compressor, quick-acting solenoid valves, and high-frequency vibrations of high-pressure feed pumps.

4.7 Isolation devices (diaphragm seals) should be installed where system fluid viscosity and fuel isolation is a consideration.

5. Services, Pressure/Temperature Limitations, and Material

5.1 Service and pressure/temperature limitations for each assembly are listed in **Table 1** and materials are listed in **Table 2** and **Table 3**. Other services, pressure/temperatures, and materials may be used provided the materials selected are compatible with the intended system media, and the pressure/temperature limitations do not exceed the limitations of the material chosen.

TABLE 2 Material List

Part No.	Nominal Size, in.	Description	Material	Specification
1	½ NPS by ½ FPT	Globe valve, thread by socket weld	alloy steel (Cr-Mo)	ASTM A182/A182M , F11
2	¼ FPT	Globe needle valve, thread, bar stock type	carbon steel	ASTM A108 , Grades 1213 and 1215
3	¼ NPS by ¼ FPT	Globe needle valve, thread by socket weld, bar stock type	carbon steel	ASTM A108 , 1213 and 1215
4	½ NPS by ½ FPT	Globe needle valve, thread by socket weld, bar stock type	carbon steel	ASTM A108 , 1213 and 1215
5	¼ NPS	Globe needle valve, socket weld, bar stock type	carbon steel	ASTM A108 , 1213 and 1215
6	¼ NPS by ¼ FPT	Globe needle valve, thread by socket weld, bar stock type	316 stainless steel	AMS-QQ-S-763
7	¼ FPT	Globe needle valve, thread, bar stock type	316 stainless steel	AMS-QQ-S-763
8	¼ NPS by ¼ FPT	Globe needle valve, thread by silbraz	bronze	ASTM B61
9	¼ FPT	Globe needle valve, thread	bronze	ASTM B61
10	½ NPS	Pipe, Schedule 80	alloy steel (Cr-Mo)	ASTM A335/A335M , P11
11	¼ NPS	Pipe, Schedule 80	carbon steel	ASTM A106/A106M , Grade B
12	½ NPS	Pipe, Schedule 80	carbon steel	ASTM A106/A106M , Grade B
13	¼ NPS	Pipe, Schedule 80	copper-nickel 90-10	ASTM B466/B466M , Alloy 706
14	¼ OD	Tubing, 0.065-in. (1.65-mm) wall	carbon steel	ASTM A106/A106M , Grade B
15	¼ OD	Tubing, 0.035-in. (0.89-mm) wall	copper	ASTM B75
16	¼ OD by ½ MPT	Connector, tube by thread, compression type	carbon steel	ASTM A108 , Grade 12L14
17	½ by ¼ NPS	Reducing insert, socket weld	carbon steel	ASTM A105/A105M , ANSI B16.11
18	¼ FPT	Tee, thread	carbon steel	ASTM A105/A105M , ANSI B16.11
19	¼ MPT	Plug, thread	carbon steel	ASTM A105/A105M , ANSI B16.11
20	¼ NPS	Tee, socket weld	carbon steel	ASTM A105/A105M , ANSI B16.11
21	¼ NPS	Union, socket weld	carbon steel	ASTM A105/A105M , ANSI B16.11
22	¼ NPS	Coupling	carbon steel	ASTM A105/A105M , ANSI B16.11
23	¼ OD by ¼ MPT	Connector, tube by thread, compression type	carbon steel	ASTM A108 , Grade 12L14
24	¼ OD	Tee, tube, compression type	carbon steel	ASTM A576 , Grade 12L14
25	¼ OD	Union, tube, compression type	carbon steel	ASTM A108 , Grade 12L14
26	¼ FPT	Tee thread	bronze	ASTM B62 , ANSI B16.15
27	¼ MPT	Plug, thread	bronze	ASTM B62 , ANSI B16.15
28	¼ OD	Union, tube, compression type	brass	ASTM B453/B453M , Alloy 345; ASTM B16/B16M , Alloy 360
29	¼ OD by ¼ MPT	Connector, tube by thread, compression type	brass	ASTM B453/B453M , Alloy 345; ASTM B16/B16M , Alloy 360
30	¼ OD	Tee, tube, compression type	brass	ASTM B124/B124M , Alloy 377
31	¼ OD by ¼ MPT	Connector, tube by thread, compression type	316 stainless steel	ASTM A276
32	¼ OD	Tee, tube, compression type	316 stainless steel	ASTM A276
33	¼ MPT by ¼ FPT	Pulsation dampener, thread	316 stainless steel	commercial
34	¼ FPT	90° elbow, thread	carbon steel	ASTM A105/A105M , ANSI B16.11
35	¼ FPT	90° elbow, thread	bronze	ASTM B62 , ANSI B16.15
36	¼ OD	Union, tube, compression type	316 stainless steel	ASTM A276