



Designation: **D4929—19a** **D4929 – 22**

## Standard Test Method for Determination of Organic Chloride Content in Crude Oil<sup>1</sup>

This standard is issued under the fixed designation D4929; the number immediately following the designation indicates the year of original adoption or, in the case of revision, the year of last revision. A number in parentheses indicates the year of last reapproval. A superscript epsilon ( $\epsilon$ ) indicates an editorial change since the last revision or reapproval.

### 1. Scope\*

1.1 The procedures in this test method cover the determination of organic chloride (above 1  $\mu\text{g/g}$  organically-bound chlorine) in crude oils, using either distillation and sodium biphenyl reduction, distillation and microcoulometry, or distillation and X-ray fluorescence (XRF) spectrometry.

1.2 The procedures in this test method involve the distillation of crude oil test specimens to obtain a naphtha fraction prior to chloride determination. The chloride content of the naphtha fraction of the whole crude oil can thereby be obtained. See Section [56](#) regarding potential interferences.

1.3 Procedure A covers the determination of organic chloride in the washed naphtha fraction of crude oil by sodium biphenyl reduction followed by potentiometric titration.

1.4 Procedure B covers the determination of organic chloride in the washed naphtha fraction of crude oil by oxidative combustion followed by microcoulometric titration.

1.5 Procedure C covers the determination of organic chloride in the washed naphtha fraction of crude oil by X-ray fluorescence spectrometry.

1.6 The values stated in SI units are to be regarded as standard. No other units of measurement are included in this standard.

1.6.1 The preferred concentration units are micrograms of chloride per gram of sample, though milligrams of chloride per kilogram of sample is commonly used for Procedure C.

1.7 *This standard does not purport to address all of the safety concerns, if any, associated with its use. It is the responsibility of the user of this standard to establish appropriate safety, health, and environmental practices and determine the applicability of regulatory limitations prior to use.*

1.8 *This international standard was developed in accordance with internationally recognized principles on standardization established in the Decision on Principles for the Development of International Standards, Guides and Recommendations issued by the World Trade Organization Technical Barriers to Trade (TBT) Committee.*

<sup>1</sup> This test method is under the jurisdiction of ASTM Committee D02 on Petroleum Products, Liquid Fuels, and Lubricants and is the direct responsibility of Subcommittee D02.03 on Elemental Analysis.

Current edition approved Dec. 1, 2019/Oct. 1, 2022. Published December 2019/October 2022. Originally approved in 1989. Last previous edition approved in 2019 as [D4929 – 19](#); [D4929 – 19a](#). DOI: [10.1520/D4929-19A](#); [10.1520/D4929-22](#).

\*A Summary of Changes section appears at the end of this standard

## 2. Referenced Documents

### 2.1 ASTM Standards:<sup>2</sup>

- [D86 Test Method for Distillation of Petroleum Products and Liquid Fuels at Atmospheric Pressure](#)
- [D1193 Specification for Reagent Water](#)
- [D4057 Practice for Manual Sampling of Petroleum and Petroleum Products](#)
- [D4175 Terminology Relating to Petroleum Products, Liquid Fuels, and Lubricants](#)
- [D4177 Practice for Automatic Sampling of Petroleum and Petroleum Products](#)
- [D6299 Practice for Applying Statistical Quality Assurance and Control Charting Techniques to Evaluate Analytical Measurement System Performance](#)
- [D6300 Practice for Determination of Precision and Bias Data for Use in Test Methods for Petroleum Products, Liquid Fuels, and Lubricants](#)
- [D6708 Practice for Statistical Assessment and Improvement of Expected Agreement Between Two Test Methods that Purport to Measure the Same Property of a Material](#)
- [D7343 Practice for Optimization, Sample Handling, Calibration, and Validation of X-ray Fluorescence Spectrometry Methods for Elemental Analysis of Petroleum Products and Lubricants](#)

## 3. Terminology

### 3.1 Definitions:

3.1.1 For definitions of terms used in this test method, refer to Terminology [D4175](#).

### 3.2 Definitions of Terms Specific to This Standard:

3.2.1 *naphtha fraction, n*—the fraction of the crude oil collected from atmospheric distillation over a boiling range up to 204 °C.

3.2.2 *organic chloride compounds, n*—compounds containing carbon and at least one chlorine.

3.2.3 *total organic chloride compounds, n*—the sum of compounds containing carbon and at least one chlorine.

## 4. Summary of Test Method

4.1 A crude oil distillation is performed to obtain the naphtha cut at 204 °C (400 °F). The distillation method was adapted from Test Method [D86](#) for the distillation of petroleum products. The naphtha cut is washed with caustic, repeatedly when necessary, until all hydrogen sulfide is removed. The naphtha cut, free of hydrogen sulfide, is then washed with water, repeatedly when necessary, to remove inorganic halides (chlorides).

4.2 There are three alternative procedures for determination of the organic chloride in the washed naphtha fraction, as follows.

4.2.1 *Procedure A, Sodium Biphenyl Reduction and Potentiometry*—The washed naphtha fraction of a crude oil specimen is weighed and transferred to a separatory funnel containing sodium biphenyl reagent in toluene. The reagent is an addition compound of sodium and biphenyl in ethylene glycol dimethyl ether. The free radical nature of this reagent promotes very rapid conversion of the organic halogen to inorganic halide. In effect this reagent solubilizes metallic sodium in organic compounds. The excess reagent is decomposed, the mixture acidified, and the phases separated. The aqueous phase is evaporated to 25 mL to 30 mL, acetone is added, and the solution titrated potentiometrically.

4.2.2 *Procedure B, Combustion and Microcoulometry*—The washed naphtha fraction of a crude oil specimen is injected into a flowing stream of gas containing about 80 % oxygen and 20 % inert gas, such as argon, helium, or nitrogen. The gas and sample flow through a combustion tube maintained at about 800 °C. The chlorine is converted to chloride and oxychlorides, which then flow into a titration cell where they react with the silver ions in the titration cell. The silver ions thus consumed are coulometrically replaced. The total current required to replace the silver ions is a measure of the chlorine present in the injected samples.

4.2.3 The reaction occurring in the titration cell as chloride enters is as follows:



<sup>2</sup> For referenced ASTM standards, visit the ASTM website, [www.astm.org](http://www.astm.org), or contact ASTM Customer Service at [service@astm.org](mailto:service@astm.org). For *Annual Book of ASTM Standards* volume information, refer to the standard's Document Summary page on the ASTM website.

4.2.4 The silver ion consumed in the above reaction is generated coulometrically thus:



4.2.5 These microequivalents of silver are equal to the number of microequivalents of titratable sample ion entering the titration cell.

4.2.6 *Procedure C, X-ray Fluorescence Spectrometry*—The washed naphtha fraction of a crude oil specimen is placed in the X-ray beam, and the peak intensity of the chlorine K $\alpha$  line is measured by monochromatic wavelength dispersive X-ray fluorescence (MWDXRF), monochromatic energy dispersive X-ray fluorescence (MEDXRF), or energy dispersive X-ray fluorescence (EDXRF) spectrometry. The resulting net counting rate is then compared to a previously prepared calibration curve or equation to obtain the concentration of chlorine in mg/kg.

## 5. Significance and Use

5.1 Organic chlorides do not occur naturally in crude oil. When present, they result from contamination in some manner, such as disposal of chlorinated solvent used in many dewaxing pipeline or other equipment operations.

5.1.1 Uncontaminated crude oil will contain no detectable organic chloride, and most refineries can handle very small amounts without deleterious effects.

5.1.1.1 Most trade contracts specify that no organic chloride is present in the crude oil.

5.1.2 Several pipelines have set specification limits at <1 mg/kg organic chlorides in the whole crude, and <5 mg/kg in the light naphtha, on the basis of the naphtha fraction being 20 % of the original sample.

5.1.2.1 To ensure <1 mg/kg organic chloride in the crude oil, the amount measured in the naphtha fraction shall be <1/f (where f is the naphtha fraction calculated with Eq 3).

5.1.3 Organic chloride present in the crude oil (for example, methylene chloride, perchloroethylene, etc.) is usually distilled into the naphtha fraction. Some compounds break down during fractionation and produce hydrochloric acid, which has a corrosive effect. Some compounds survive fractionation and are destroyed during hydro-treating (desulfurization of the naphtha).

<https://standards.iteh.ai/catalog/standards/sist/47d177b3-5ecc-43d5-91f1-c740d53ae830/astm-d4929-22>

5.2 Other halides can also be used for dewaxing crude oil; in such cases, any organic halides will have similar impact on the refining operations as the organic chlorides.

5.3 Organic chloride species are potentially damaging to refinery processes. Hydrochloric acid can be produced in hydrotreating or reforming reactors and the acid accumulates in condensing regions of the refinery. Unexpected concentrations of organic chlorides cannot be effectively neutralized and damage can result. Organic chlorides are not known to be naturally present in crude oils and usually result from cleaning operations at producing sites, pipelines, or tanks. It is important for the oil industry to have common methods available for the determination of organic chlorides in crude oil, particularly when transfer of custody is involved.

## 6. Interferences

6.1 *Procedure A*—Other titratable halides will also give a positive response. These titratable halides include HBr and HI.

6.2 *Procedure B*—Other titratable halides will also give a positive response. These titratable halides include HBr and HI (HOBr and HOI do not precipitate silver). Since these oxyhalides do not react in the titration cell, approximately 50 % microequivalent response is detected.

6.2.1 This procedure is applicable in the presence of total sulfur concentration of up to 10 000 times the chlorine level.

6.3 *Procedure C*—X-ray fluorescence spectrometry techniques may have interferences due to high sulfur content and matrix effects due to differences in the carbon-hydrogen ratio.

6.3.1 Matrix effects result when the elemental composition (excluding chlorine) of samples differs significantly from the standards, and significant errors in the chlorine determination can result. For example, differences in the carbon-hydrogen ratio of sample and calibration standards introduce errors in the determination.

6.3.2 In general, naphthas with compositions that vary from white oils as specified in [27-128.1](#) can be analyzed with standards made from base materials that are of the same or similar composition. A base material for naphtha may be simulated by mixing isooctane and toluene in a ratio that approximates the expected aromatic content of the samples to be analyzed.

6.3.3 Naphtha samples may contain high amounts ( $\geq 0.5$  mass %) of sulfur leading to significant absorption of chlorine K $\alpha$  radiation and low chlorine results. Such samples can, however, be analyzed using this test method provided either that the calibration standards are prepared to match the matrix of the sample or correction factors are applied to the results. In some cases, dilution of samples with sulfur-free and chlorine-free oil can be used to reduce the effect. The main disadvantage is, however, that dilution also lowers the amount of chlorine in the specimen. Make sure that in the diluted specimen, the chlorine content is higher than 1 mg/kg before resorting to dilution.

6.3.4 Matrix matching requires the knowledge of typical sulfur concentration in the naphtha sample and preparing calibration standards, which contain a similar sulfur concentration. This technique is not applicable for naphtha samples with an unknown or differing sulfur content than the calibration samples.

6.3.5 Sulfur correction factors are typically applied by using the software and algorithms supplied by the equipment vendor and typically uses one of the following forms: manual input of sulfur concentration followed by automatic correction, direct measurement of sulfur followed by automatic correction, correction by use of Compton scattering, and correction by applying fundamental parameters. Follow manufacturer's instructions for application of sulfur correction factors and when to apply those factors.

## 7. Purity of Reagents

7.1 *Purity of Reagents*—Reagent grade chemicals shall be used in all tests. Unless otherwise indicated, it is intended that all reagents shall conform to the specifications of the Committee on Analytical Reagents of the American Chemical Society, where such specifications are available.<sup>3</sup> Other grades may be used, provided it is first ascertained that the reagent is of sufficiently high purity to permit its use without lessening the accuracy of the determination.

7.2 *Purity of Water*—Unless otherwise indicated, references to water shall be understood to mean reagent water as defined by Type III of Specification [D1193](#).

## DISTILLATION AND CLEANUP PROCEDURE

### 8. Apparatus

8.1 *Round-Bottom Boiling Flask*, borosilicate, 1 L, single short neck with 24/40 outer ground-glass joint.

8.2 *Tee Adapter*, borosilicate, 75° angle side-arm, 24/40 ground-glass joints.

8.3 *Thermometer*, ASTM thermometer 2C (–5 °C to 300 °C) or 2F, (20 °F to 580 °F).

8.3.1 Other temperature measuring devices, such as thermocouples or resistance thermometers, may be used when the temperature reading obtained by these devices is determined to produce the same naphtha fraction that is obtained when mercury-in-glass thermometers are used.

8.4 *Thermometer Adapter*, borosilicate, 24/40 inner ground-glass joint.

8.5 *Liebig Condenser*, borosilicate, 300 mm length, 24/40 ground-glass joints.

<sup>3</sup> ACS Reagent Chemicals, *Specifications and Procedures for Reagents and Standard-Grade Reference Materials*, American Chemical Society, Washington, DC. For suggestions on the testing of reagents not listed by the American Chemical Society, see *Analar Standards for Laboratory Chemicals*, BDH Ltd., Poole, Dorset, U.K., and the *United States Pharmacopeia and National Formulary*, U.S. Pharmacopeial Convention, Inc. (USPC), Rockville, MD.

- 8.6 *Vacuum Take-Off Adapter*, borosilicate, 105° angle bend, 24/40 ground-glass joints.
- 8.7 *Receiving Cylinder*, borosilicate, 250 mL capacity, 24/40 outer ground-glass joint.
- 8.8 *Wire Clamps*, for No. 24 ground-glass joints, stainless steel.
- 8.9 *Receiver Flask*, for ice bath, 4 L.
- 8.10 *Copper Tubing*, for heat exchanger to cool condenser water, 6.4 mm outside diameter, 3 m length.
- 8.11 *Electric Heating Mantle*, Glas-Col Series 0, 1 L size, 140 W upper heating element, 380 W lower heating element.
- 8.12 *Variacs*, 2, for temperature control of upper and lower heating elements, 120 V, 10 amps.

## 9. Reagents and Materials

- 9.1 *Acetone*, chloride-free. (**Warning**—Extremely flammable, can cause flash fires. Health hazard.)
- 9.2 *Caustic Solution*, 1 M potassium hydroxide (**Warning**—Can cause severe burns to skin.) prepared in distilled/deionized water.
- 9.3 *Distilled/Deionized Water*.
- 9.4 *Filter Paper*, Whatman No. 41 or equivalent.
- 9.5 *Stopcock Grease*.<sup>4,5</sup>
- 9.6 *Toluene*, chloride-free. (**Warning**—Flammable. Health hazard.)

## 10. Sampling

10.1 Obtain a test unit in accordance with Practice **D4057** or **D4177**. To preserve volatile components, which are in some samples, do not uncover samples any longer than necessary. Samples should be analyzed as soon as possible, after taking from bulk supplies, to prevent loss of organic chloride or contamination due to exposure or contact with sample container. (**Warning**—Samples that are collected at temperatures below room temperature may undergo expansion and rupture the container. For such samples, do not fill the container to the top; leave sufficient air space above the sample to allow room for expansion.)

10.2 If the test unit is not used immediately, then thoroughly mix in its container prior to taking a test specimen. Some test units can require heating to thoroughly homogenize. (**Warning**—When heating is required, care should be taken so that no organic chloride containing hydrocarbons are lost.)

## 11. Preparation of Apparatus

11.1 Clean all glassware by rinsing successively with toluene and acetone. After completing the rinse, dry the glassware using a stream of dry nitrogen gas. Obtain and record the masses of the round-bottom flask and receiving cylinder. Assemble the glass distillation apparatus using stopcock grease to seal all joints and wire clamps to prevent loosening of the joints. Adjust the thermometer position within the adapter tee such that the lower end of the capillary is level with the highest point on the bottom of the inner wall of the adapter tee section that connects to the condenser.

---

<sup>4</sup> The sole source of supply of the stop-cock grease known to the committee at this time is Dow Corning silicone, available from Dow Corning Corporation, Corporate Center, PO Box 994, Midland, MI.

<sup>5</sup> If you are aware of alternative suppliers, please provide this information to ASTM International Headquarters. Your comments will receive careful consideration at a meeting of the responsible technical committee, <sup>1</sup> which you may attend.

NOTE 1—A diagram illustrating the appropriate positioning of the thermometer can be found in Fig. 1 (from Test Method D86).

11.2 Form the copper tubing into a coil to fit inside the receiver flask, leaving room in the center of the flask for the receiving cylinder. With the PVC tubing, connect one end of the copper coil to the water source, and connect the other end of the coil to the lower fitting of the Liebig condenser cooling jacket. Connect the upper condenser fitting to the water drain. Fill the receiver flask with an ice/water mixture, and turn on the water. Maintain the temperature of the condenser below 10 °C.

**12. Procedure**

12.1 Add a 500 mL crude oil test specimen to tared round bottom flask. Obtain and record the mass of the crude oil-filled flask to the nearest 0.1 g. Connect the flask to the distillation apparatus. Place the heating mantle around the flask, and support the heating mantle/flask from the bottom. Connect the heating mantle to the variacs. Turn on the variacs and start the distillation. During the distillation, adjust the variac settings to give a distillation rate of approximately 5 mL/min. Continue the distillation until a thermometer reading of 204 °C (400 °F) is attained. When the temperature reaches 204 °C (400 °F), end the distillation by first disconnecting and removing the receiving cylinder. After the receiving cylinder has been removed, turn off the variacs and remove the heating mantle from the flask. Obtain and record the mass of the receiving cylinder and distillate.

12.1.1 The precision and bias statements were determined using mercury-in-glass thermometers only. Therefore, when alternate temperature measuring devices are used, the cut-off temperature so obtained shall be that which will produce a naphtha cut similar to what would be yielded when mercury-in-glass thermometers are used. Such alternate temperature measuring devices shall not be expected to exhibit the same temperature lag characteristics as mercury-in-glass thermometers.

12.2 Transfer the naphtha fraction from the receiving cylinder to the separatory funnel. Using the separatory funnel, wash the naphtha fraction three times with equal volumes of the caustic solution (1 M KOH). Follow the caustic wash with a water wash, again washing three times with equal volumes. The caustic wash removes hydrogen sulfide, while the water wash removes traces of inorganic chlorides either originally present in the crude or from impurities in the caustic solution. After the washings are complete, filter the naphtha fraction to remove residual freestanding water. Store the naphtha fraction in a clean glass bottle. This naphtha fraction can now be analyzed for organic chlorides by either sodium biphenyl, combustion/microcoulometric techniques, or X-ray fluorescence spectrometry.

12.3 Measure the density of the crude oil specimen and the naphtha fraction by obtaining the mass of 10.0 mL (using a 10 mL volumetric flask) of each to the nearest 0.1 g.

**13. Calculation**

13.1 Calculate naphtha fraction as follows:

$$f = M_n / M_c \tag{3}$$

where:

$f$  = mass fraction of naphtha collected,  
 $M_n$  = mass of naphtha collected, and

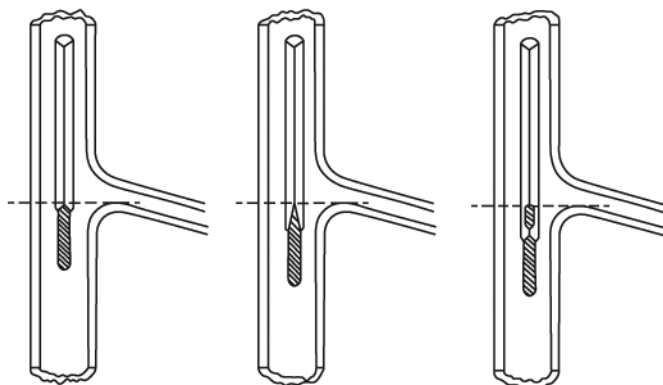

**FIG. 1 Position of Thermometer in Distillation Flask**

$M_c$  = mass of crude oil specimen.

13.2 Calculate the density as follows:

$$\text{Density, g/mL} = m/v \quad (4)$$

where:

$m$  = mass of sample specimen, g, and

$v$  = volume of sample specimen, mL.

## PROCEDURE A—SODIUM BIPHENYL REDUCTION AND POTENTIOMETRY

### 14. Apparatus

14.1 *Electrodes*—The cleaning and proper care of electrodes are critical to the accuracy of this test. Manufacturer's instructions for the care of electrodes shall be followed.

14.1.1 *Glass*, general purpose. When glass electrodes are in continuous use, weekly cleaning with chrome-sulfuric acid (**Warning**—Strong oxidizer; can cause severe burns; recognized carcinogen), or other strongly oxidizing cleaning solution, is recommended.

14.1.2 *Silver-Silver Chloride*, billet-type.

14.2 *Titration*, potentiometric. The titration is equipped with a 5 mL or smaller buret and a magnetic stirring motor.

### 15. Reagents and Materials

15.1 *Acetone*, chloride-free. (**Warning**—Extremely flammable, can cause flash fires. Health hazard.)

15.2 *Congo Red Paper*.

15.3 *2,2,4, trimethyl pentane (isooctane)*, reagent grade. (**Warning**—Flammable. Health hazard.)

15.4 *Nitric Acid*, approximately 5 M. (**Warning**—Corrosive, causes severe burns.) Add 160 mL of concentrated nitric acid to about 200 mL of water and dilute to 500 mL.

15.5 *2-Propanol*, chloride-free. (**Warning**—Flammable. Health hazard.)

15.6 *Silver Nitrate*, 0.01 M, standard aqueous solution.

15.7 *Sodium Biphenyl Reagent*<sup>5,6</sup>—This is packed in 0.5 oz French square bottles (hereafter referred to as vials). The entire contents of one vial are used for each analysis. One vial contains 13 meq to 15 meq of active sodium. Store the sodium biphenyl reagent in a cool storage area, but do not refrigerate. Prior to using, warm the reagent to approximately 50 °C and shake thoroughly to ensure a homogeneous liquid.

15.8 *Toluene*, chloride-free. (**Warning**—Flammable. Health hazard.)

### 16. Preparation of Apparatus

16.1 *Recoating Silver-Silver Chloride Electrodes*—Clean the metal surfaces of a pair of silver-silver chloride electrodes with mild detergent and scouring powder. Rinse the electrodes in distilled water. Immerse the metallic tips in saturated potassium chloride solution. Connect one electrode to the positive pole of a 1.6 V battery and the other to the negative pole. Reverse the polarity for

<sup>6</sup> The sole source of supply of the sodium biphenyl reagent known to the committee at this time is Southwestern Analytical Chemicals, P.O. Box 485, Austin, TX.

several intervals of a few seconds each to alternately clean and recoat the receptor electrode (connected to the positive pole). When adequately coated, the receptor electrode tip will turn violet in color. This results from the action of light on the fresh silver chloride.

## 17. Procedure

17.1 Use extreme care to prevent contamination. Reserve all glassware for the chloride determination. Rinse glassware with distilled water followed by acetone just prior to use. Avoid using chlorine-containing stopcock greases such as chlorotrifluoroethylene polymer grease.

17.2 Place 50 mL of toluene in a 250 mL separatory funnel and add the contents of one vial of sodium biphenyl reagent. Swirl to mix and add about 30 g, obtaining the mass to the nearest 0.1 g of the washed naphtha fraction of crude oil sample. Obtain the mass of the sample bottle to determine the exact amount taken. Stopper the separatory funnel and swirl to mix the contents thoroughly. The solution or suspension that results should be blue-green in color. When it is not, add more sodium biphenyl reagent (one vial at a time) until the solution or suspension is blue-green.

17.3 Allow 10 min after mixing for the reaction to be completed, then add 2 mL of 2-propanol and swirl gently with the funnel unstoppered for a time until the blue-green color changes to white, indicating that no free sodium remains. Stopper the funnel and rock it gently, venting pressure frequently through the stopcock. Then add 20 mL of water and 10 mL of 5 *M* nitric acid. Shake gently, releasing the pressure frequently through the stopcock. Test the aqueous phase with Congo red paper. If the paper does not turn blue, add additional 5 *M* nitric acid in 5 mL portions until the blue color is obtained.

17.4 Drain the aqueous phase into another separatory funnel containing 50 mL of *isooctane* and shake well. Drain the aqueous phase into a 250 mL titration beaker. Make a second extraction of the *isooctane* phase with 25 mL of water that has been acidified with a few drops of 5 *M* nitric acid. Add this second extract to the 250 mL titration beaker. Evaporate the solution on a hot plate kept just below the boiling point of the liquid until 25 mL to 30 mL remains. Do not boil or evaporate to less than 25 mL as loss of chloride may occur.

17.5 Cool the solution and add 100 mL of acetone. Titrate the solution potentiometrically with standard 0.01 *M* silver nitrate, using glass versus silver-silver chloride electrodes. If an automatic titrator, such as a Metrohm, is available, use the semi-micro 5 mL piston buret. If the titration is carried out with a manually-operated pH meter, use a 5 mL semi-micro buret that can be estimated to three decimal places in millilitres.

17.6 Determine the endpoint for the manual titration by plotting the data showing emf versus volume of silver nitrate solution used. Determine the endpoint for the automatic titrator from the midpoint of the inflection of the titration curve.

17.7 Determine a blank for each group of test specimens by using all of the reagents, including the sodium biphenyl, and following all the operations of the analysis except that the sample itself is omitted.

## 18. Calculation

18.1 Calculate chloride concentration in the naphtha fraction as follows:

$$\text{Chloride, } \mu\text{g/g} = \frac{(A - B) (M) (35\ 460)}{W} \quad (5)$$

where:

- A* = volume of titrant for the sample specimen, mL,
- B* = volume of titrant for the blank, mL,
- M* = molarity of silver nitrate, and
- W* = mass of sample specimen, g.

18.2 The concentration of organic chloride in the original crude oil sample specimen can be obtained by multiplying the chloride concentration in the naphtha fraction (see [17-18.1](#)) by the naphtha fraction (see [12-13.1](#)).



## PROCEDURE B—COMBUSTION AND MICROCOULOMETRY

### 19. Apparatus

19.1 *Combustion Furnace*—The sample specimen is to be oxidized in an electric furnace capable of maintaining a temperature of 800 °C to oxidize the organic matrix.

19.2 *Combustion Tube*—Fabricated from quartz and constructed so a sample, which is vaporized completely in the inlet section, is swept into the oxidation zone by an inert gas where it mixes with oxygen and is burned. The inlet end of the tube shall hold a septum for syringe entry of the sample and side arms for the introduction of oxygen and inert gases. The center section is to be of sufficient volume to ensure complete oxidation of the sample.

19.3 *Titration Cell*—Containing a sensor-reference pair of electrodes to detect changes in silver ion concentration and a generator anode-cathode pair of electrodes to maintain constant silver ion concentration and an inlet for a gaseous sample from the pyrolysis tube. The sensor, reference, and anode electrodes shall be silver electrodes. The cathode electrode shall be a platinum wire. The reference electrode resides in a saturated silver acetate half-cell. The electrolyte contains 70 % acetic acid in water.

19.4 *Microcoulometer*, having variable gain and bias control, and capable of measuring the potential of the sensing-reference electrode pair, and of comparing this potential with a bias potential, and of applying the amplified difference to the working-auxiliary electrode pair so as to generate a titrant. The microcoulometer output signal shall be proportional to the generating current. The microcoulometer may have a digital meter and circuitry to convert this output signal directly to nanograms or micrograms of chloride.

19.5 *Sampling Syringe*—A microlitre syringe of 50 µL capacity capable of accurately delivering 5 µL to 50 µL of sample into the pyrolysis tube. A 3 in. or 6 in. (76.2 mm or 152.4 mm) needle is recommended to reach the inlet zone of approximately 500 °C in the combustion zone.

19.6 A constant rate syringe pump or manual dispensing adaptor may be used to facilitate slow injection of the sample into the combustion tube. It is recommended that the injection rate not exceed 0.5 µL/s.

### 20. Reagents and Materials

20.1 *Acetic Acid*, glacial acetic acid. (**Warning**—Corrosive, causes severe burns.)

20.2 *Argon, Helium, Nitrogen, or Carbon Dioxide*, high purity grade (HP) used as the carrier gas. (**Warning**—These gases are normally stored in cylinders under high pressure. These gases also dilute the oxygen content of the surrounding air when they leak.)

20.3 *Cell Electrolyte Solution*, 70 % acetic acid, combine 300 mL reagent water (see [6.27.2](#)) with 700 mL acetic acid (see [19.1](#) and [20.1](#)) and mix well.

20.4 *Chloride, Standard Stock Solution*, 1000 mg chloride per litre. Accurately dispense 1.587 g of chlorobenzene into a 500 mL volumetric flask and dilute to volume with 2,2,4,trimethyl pentane (*isooctane*).

NOTE 2—The exact concentration of chloride may be determined by multiplying the mass of chlorobenzene by the product of the atomic mass of chlorine divided by the molecular mass of chlorobenzene and then multiplying that result by 2000.

$$\text{Cl (mg/L)} = \frac{w \times m_1 \times 2000}{m_2} \quad (6)$$

where:

$w$  = mass of chlorobenzene weighed,  
 $m_1$  = atomic mass of chlorine, and  
 $m_2$  = molecular mass of chlorobenzene.

20.5 *Chlorine, Standard Solution*, 10 mg chloride per litre. Pipet 1.0 mL of chloride stock solution (see [19.420.4](#)) into a 100 mL volumetric flask and dilute to volume with 2,2,4-trimethyl pentane (*isooctane*).

20.6 *Chlorobenzene*, reagent grade.

20.7 *Gas Regulators*, two-stage gas regulator must be used on the reactant and carrier gas.

20.8 *Isooctane*, 2,2,4-trimethylpentane, reagent grade.

20.9 *Oxygen*, high purity grade, used as the reactant gas.

20.10 *Silver Acetate*, powder purified for saturated reference electrode.

## 21. Preparation of Apparatus

21.1 Set up the analyzer in accordance with the equipment manufacturer instructions.

21.2 The typical operational conditions are as follows:

Reactant gas flow, O <sub>2</sub>	160 mL/min
Carrier gas flow	40 mL/min
Furnace temperature:	
Inlet zone	700 °C
Center and outlet zones	800 °C
Coulometer:	
Bias voltage, mV	240 to 265
Gain	ca. 1200

21.3 Optimize the bias voltage setting for the titration cell null-point by injecting 30 µL of chloride-free water directly into the titration cell using a 6 in. needle. Adjust bias up or down to minimize the total integrated value due to this dilution effect.

## 22. Procedure

22.1 Fill a 50 µL syringe with about 30 µL to 40 µL of the sample of washed naphtha fraction of crude oil, being careful to eliminate bubbles. Then retract the plunger so that the lower liquid meniscus falls on the 5 µL mark, and record the volume of liquid in the syringe. After the sample has been injected, again retract the plunger so that the lower liquid meniscus falls on the 5 µL mark, and record the volume of liquid in the syringe. The difference in the two volume readings is the volume of sample injected.

22.2 Alternately, obtain the sample injection device mass before and after injection to determine the amount of sample injected. This method provides greater precision than the volume delivery method, provided a balance with a precision of ±0.01 mg is used and the syringe is carefully handled to obtain repeatable weighings.

22.3 Inject the sample into the pyrolysis tube at a rate not to exceed 0.5 µL/s.

22.4 Below 5 µg/g, the needle-septum blank will become increasingly more obvious. To improve precision, insert the syringe needle into the hot inlet and then wait until the needle-septum blank is titrated before injecting the sample or standard.

22.5 For specimens containing more than 25 µg/g Cl only 5.0 µL of sample need be injected.

22.6 Verify the system recovery, the fraction of chlorine in the standard that is titrated, every 4 h by using the standard solution (see [19.520.5](#)). System recovery is typically 85 % or better.

22.7 Repeat the measurement of the calibration standard at least three times.

22.8 Check the system blank daily with reagent grade *isooctane* (see [19.820.8](#)). Subtract the system blank from both sample and standard data. The system blank is typically less than 0.2 µg/g chloride once the needle-septum blank has been titrated (see [21.422.4](#)).

### 23. Calculation

23.1 Calculate chloride concentration in the naphtha fraction as follows:

23.1.1 For microcoulometers, which read directly in nanograms of chloride, the following equations apply:

$$\text{Chloride, } \mu\text{g/g} = \frac{\text{Sample Readout}}{(V)(D)(RF)} - \frac{\text{Blank Readout}}{(V)(D)(RF)} \quad (7)$$

or

$$\text{Chloride, } \mu\text{g/g} = \frac{\text{Sample Readout}}{(M)(RF)} - \frac{\text{Blank Readout}}{(M)(RF)} \quad (8)$$

where:

Readout = displayed integrated value (sample/standard/ blank),

$V$  = volume injected µL,

$\bar{D}$  = density, g/mL ([11.3](#)),

$D$  = density, g/mL ([12.3](#)),

$RF$  = recovery factor, ration of chloride determined in standard divided by known standard content minus the system blank.

$$RF = \frac{\text{Standard Readout}}{(V)(D)(C_s)} - \frac{\text{Blank Readout}}{(V)(D)(C_s)}$$

$M$  = mass of sample specimen, mg, and

$C_s$  = concentration of standard, mg/L

23.1.2 For microcoulometers with only analog signal output to a recorder the following equation applies:

$$\text{Chloride, } \mu\text{g/g} = \frac{(A)(X)(0.367)}{(R)(Y)(M)(RF)} - B \quad (9)$$

where:

$A$  = area in appropriate units,

$X$  = recorder sensitivity for full-scale response, mV,

0.367 =

$$\frac{(35.45 \text{ gCl/eq})(10^{-3} \text{ V/mV})(10^6 \mu\text{g/g})}{(96500 \text{ coulombs/eq})}$$

$R$  = resistance, Ω,

$Y$  = area equivalence for a full-scale response on the recorder per second-area units per second,

$M$  = mass of sample, g,

$RF$  = recovery factor, and

$B$  = system blank, µg/g Cl.

23.2 The concentration of organic chloride in the original crude oil sample specimen can be obtained by multiplying the chloride concentration in the naphtha fraction (see [22.123.1](#)) by the naphtha fraction (see [12.113.1](#)).

## PROCEDURE C—X-RAY FLUORESCENCE SPECTROMETRY

### 24. Apparatus

24.1 Any spectrometer of the following type: *Monochromatic Wavelength Dispersive X-ray Fluorescence (MWDXRF) Spectrometer*; *Monochromatic Energy Dispersive X-ray Fluorescence (MEDXRF) Spectrometer*; or *Energy Dispersive X-ray Fluorescence (EDXRF) Spectrometer* can be used if it includes the following features for its type described in this section and the