



Designation: E72 – 22

# Standard Test Methods of Conducting Strength Tests of Panels for Building Construction<sup>1</sup>

This standard is issued under the fixed designation E72; the number immediately following the designation indicates the year of original adoption or, in the case of revision, the year of last revision. A number in parentheses indicates the year of last reapproval. A superscript epsilon (ε) indicates an editorial change since the last revision or reapproval.

*This standard has been approved for use by agencies of the U.S. Department of Defense.*

## INTRODUCTION

Sound engineering design of structures using existing or new materials requires accurate technical data on the strength and rigidity of the basic elements employed in various construction systems. It is the purpose of these test methods to provide a systematic basis for obtaining engineering data on various construction elements and structural details of value to designers, builders, building officials, and others interested in this field. The results should closely approximate the performance in actual service.

## 1. Scope

1.1 These test methods cover the following procedures for determining the structural properties of segments of wall, floor, and roof constructions:

Test Specimens	Section 3
Loading	4
Deformation Measurements	5
Reports	6
Precision and Accuracy	7
TESTING WALLS	
Significance and Use	8
Compressive Load	9
Tensile Load	10
Transverse Load—Specimen Horizontal	11
Transverse Load—Specimen Vertical	12
Concentrated Load	13
Impact Load—See Test Methods E695 and E661	
Racking Load—Evaluation of Sheathing Materials on a Standard Wood Frame	14
Racking Load—Evaluation of Sheathing Materials (Wet) on a Standard Wood Frame	15
TESTING FLOORS	
Significance and Use	16
Transverse Load	17
Concentrated Load	18
Impact Load—See Test Methods E695 and E661	
TESTING ROOFS	
Significance and Use	Section 19
Transverse Load	20

<sup>1</sup> These test methods are under the jurisdiction of ASTM Committee E06 on Performance of Buildings and are the direct responsibility of Subcommittee E06.11 on Horizontal and Vertical Structures/Structural Performance of Completed Structures.

Current edition approved Oct. 1, 2022. Published October 2022. Originally approved in 1947. Last previous edition approved in 2015 as E72 – 15. DOI: 10.1520/E0072-22.

Concentrated Load	21
APPENDIX	
Technical Interpretation	Appendix X1

1.2 The values stated in inch-pound units are to be regarded as standard. The values given in parentheses are mathematical conversions to SI units that are provided for information only and are not considered standard.

1.3 *This standard does not purport to address all of the safety concerns, if any, associated with its use. It is the responsibility of the user of this standard to establish appropriate safety, health, and environmental practices and determine the applicability of regulatory limitations prior to use.*

1.4 *This international standard was developed in accordance with internationally recognized principles on standardization established in the Decision on Principles for the Development of International Standards, Guides and Recommendations issued by the World Trade Organization Technical Barriers to Trade (TBT) Committee.*

## 2. Referenced Documents

- 2.1 *ASTM Standards:*<sup>2</sup>
- D2395 Test Methods for Density and Specific Gravity (Relative Density) of Wood and Wood-Based Materials
  - D4442 Test Methods for Direct Moisture Content Measurement of Wood and Wood-Based Materials
  - D7438 Practice for Field Calibration and Application of Hand-Held Moisture Meters

<sup>2</sup> For referenced ASTM standards, visit the ASTM website, www.astm.org, or contact ASTM Customer Service at service@astm.org. For *Annual Book of ASTM Standards* volume information, refer to the standard's Document Summary page on the ASTM website.

- [E4 Practices for Force Calibration and Verification of Testing Machines](#)
- [E73 Practice for Static Load Testing of Truss Assemblies](#)
- [E564 Practice for Static Load Test for Shear Resistance of Framed Walls for Buildings](#)
- [E575 Practice for Reporting Data from Structural Tests of Building Constructions, Elements, Connections, and Assemblies](#)
- [E661 Test Method for Performance of Wood and Wood-Based Floor and Roof Sheathing Under Concentrated Static and Impact Loads](#)
- [E695 Test Method of Measuring Relative Resistance of Wall, Floor, and Roof Construction to Impact Loading](#)
- [E2126 Test Methods for Cyclic \(Reversed\) Load Test for Shear Resistance of Vertical Elements of the Lateral Force Resisting Systems for Buildings](#)
- [E2309/E2309M Practices for Verification of Displacement Measuring Systems and Devices Used in Material Testing Machines](#)
- [E2322 Test Method for Conducting Transverse and Concentrated Load Tests on Panels used in Floor and Roof Construction](#)

## 2.2 Other Document:<sup>3</sup>

[NIST Voluntary Product Standard PS20 American Softwood Lumber Standard](#)

## 3. Test Specimens

3.1 *Size*—There shall be at least three specimens for each test. Specimens shall be constructed to represent sections of the wall, floor, or roof assembly. The specimens shall be representative as to material and workmanship and shall be of the largest practical size to predict structural performance attributes of the assembly. Unsymmetrical assemblies shall be tested in each axis for which the results may be different.

3.2 *Length or Height*—The length or height of specimen for each element shall be chosen to conform to the length or height of that element in actual use.

3.3 *Width*—The width of specimen shall be chosen, insofar as possible, to include several of the principal load-carrying members to ensure that the behavior under load will simulate that under service conditions. With the exception of specimens for the racking load test, the nominal width of wall specimens shall be 4 ft (1.2 m). The actual width of specimens shall be a whole number multiplied by the spacing of the principal load-carrying members except for prefabricated panels, for which the actual width shall be the width of panel used. If the structural properties of a particular construction are to be compared with another construction, there should not be a great difference in the actual widths of the specimens.

3.4 *Age*—Constructions, such as concrete and masonry (brick, structural clay tile, concrete block) for which the structural properties depend upon the age of the specimen, shall be tested not less than 25 days nor more than 31 days after

fabrication. This age requirement applies also to plastered and stuccoed constructions.

## 4. Loading

4.1 *Apparatus*—The testing machine or load-measuring apparatus shall comply with the requirements prescribed in Practices [E4](#).

4.2 *Application of Load*—Apply the load to all of the specimens in any test in increments so chosen that a sufficient number of readings will be obtained to determine definitely the load-deformation curve (see Section [6](#)). Record the initial reading of the load and the reading of the deformation, either with no load on the specimen or under a small initial load. Increase the load to the first increment and record the deformation. Unless otherwise specified, decrease the load to the initial load and record the set (sometimes designated “permanent set”). Increase the load to two increments and record the set, when it is released to the initial load. Follow this sequence of readings for three increments, four increments, and so forth, of load. When for each specimen the behavior of the specimen under load indicates that the specimen might fail suddenly and damage the deformation-measuring apparatus, remove this apparatus from the specimen and increase the load continuously until the maximum load that can be applied to the specimen is determined.

4.3 *Duration of Load Application*—Except for racking tests, after each increment of load is applied, maintain the load level as constant as possible for a period of 5 min (see [Note 1](#)). Take deformation readings as soon as practical after load application, at the end of the 5 min period under constant load, and immediately and at the end of the 5 min period after any partial or complete load release. Plot initial and 5 min readings in the form of load-deformation curves. Maintain complete load-deformation-time records throughout the test. If application of a given load is required for a certain period, such as 24 h, take deformation readings at the beginning, at intervals during this period, and at the end of this period, to allow the satisfactory plotting of a time-deformation curve for the complete period.

NOTE 1—Reasons for the 5 min application of constant-level increment loads are as follows:

(1) To permit the assembly to come to a substantial rest prior to taking the second set of readings (Depending on the method employed for applying the test load, it may be necessary to continue, at a reduced rate, the motion of the loading device in order to maintain the constant load level during the 5 min period.)

(2) To provide sufficient time for making all observations. (Longer time intervals may be required under certain conditions.)

(3) To observe any time-dependent deformation or load redistribution, or both, and to record accurately the load level when time-dependent deformation starts, that is, at the divergence of the immediate and delayed load-deformation curves. This load level may, under certain conditions, have an important bearing on the design load.

(4) To be able to stop the test, if this should be desirable, prior to total failure, after initial failure has been anticipated as a result of the observations.

(5) To assure uniformity in test performance and consistency in test results.

<sup>3</sup> Available from National Institute of Standards and Technology (NIST), 100 Bureau Dr., Stop 1070, Gaithersburg, MD 20899-1070, <http://www.nist.gov>.

**5. Deformation Measurements**

5.1 Measure the deformations with sufficient precision to define the load-deformation relationship, and report at least to the nearest 0.01 in. (0.25 mm). The deformation-measuring apparatus specified for any loading may be replaced by other apparatus, provided that it permits readings of deformation that are equivalent in accuracy to those from the specified apparatus.

**6. Reports**

6.1 Show the results of each of the tests graphically, as illustrated in Fig. 1. Plot loads as ordinates and the deformations as abscissas for all tests. There shall be at least three specimens for each test, and the results for each test shall be shown on the same graph. Show the points for deformation under load by open circles and those for set by solid circles. Average the three values for either the deformation or the set and plot this average value in pencil on the graph. Draw a smooth curve among the average points to show the average behavior of the construction. The load-deformation curves shall be continuous lines and the load-set curves shall be dashed lines. Although the particular specimen for each point on the graph is not designated, record it on the laboratory data sheets. If readings are obtained under greater loads for some specimens than for others, plot all the values, but draw the curves only to the average values for which there are three values.

6.2 Prepare the test report in accordance with Practice E575.

**7. Precision and Bias**

7.1 No statement is made either on the precision or on the bias of these test methods due to the variety of materials and combinations of materials involved.

**TESTING WALLS**

**8. Significance and Use**

8.1 The procedures described are those that will test the behavior of segments of wall construction under conditions

representative of those encountered in service. Performance criteria based on data from those procedures can ensure structural adequacy and service life.

**9. Compressive Load**

9.1 *Test Specimens*—Tests shall be made on three like specimens, each having a height equal to the length of the element and a nominal width of 4 ft (1.2 m) (see Section 3).

9.2 *Apparatus*—The apparatus shall be assembled as shown in Fig. 2 and shall conform to the detailed requirements for component parts prescribed in 9.2.1 and 9.2.2, or the equivalent.

9.2.1 *Compressometer*—A bracket shall be attached to the specimen near the upper end, supporting a metal rod. A bracket shall also be attached to the specimen near its lower end, supporting a deflection—measuring device with the spindle up and the gage length shall be recorded. The conical end of the rod shall seat in a hole in the end of the spindle and the rod and spindle shall be held in contact by stretched rubber bands. The deflection—measuring device shall be graduated to 0.001 in. (0.025 mm) or less.

9.2.2 *Deflectometer*—A fine wire shall be attached to a clamp near the upper end of the specimen. The free end connected to stretched rubber bands shall be attached to a clamp near the lower end of the specimen. A mirror having a paper scale one-half the width of the mirror shall be attached horizontally to the edge of the specimen at mid-height. The scale shall be graduated to 0.1 in. (2.5 mm) or less.

9.3 *Procedure:*

9.3.1 *Loading*—Test the specimen as a column having a flat end at the bottom (Fig. 2). Apply compressive loads to a steel plate covering the upper end of the specimen. Apply the load uniformly along a line parallel to the inside face, and one-third the thickness of the specimen from the inside face. For wood construction, a rate of loading corresponding to a movement of the testing machine crosshead of nominally 0.03 in./min (0.8 mm/min) has been found satisfactory.

9.3.2 *Load-Deformation Data*—Attach four compressometers to the faces of the specimen, one near each corner of the specimen as shown in Fig. 2, to measure the shortening of the specimen. Record the readings to the nearest 0.001 in. (0.025 mm).

9.3.3 *Lateral Deflection*—Attach two deflectometers, one to each edge of the specimen, as shown in Fig. 2. Record the readings, when the image of the wire coincides with the wire, to the nearest 0.01 in. (0.25 mm).

9.4 *Calculations and Report:*

9.4.1 *Deformation*—For each compressometer, calculate the shortening under each load as the difference between the reading of the compressometer when the load is applied and the initial reading. Calculate the shortening of the specimen as the average of the shortenings for each of the four compressometers multiplied by the ratio: specimen length divided by the compressometer gage length. Obtain the sets in a similar manner.

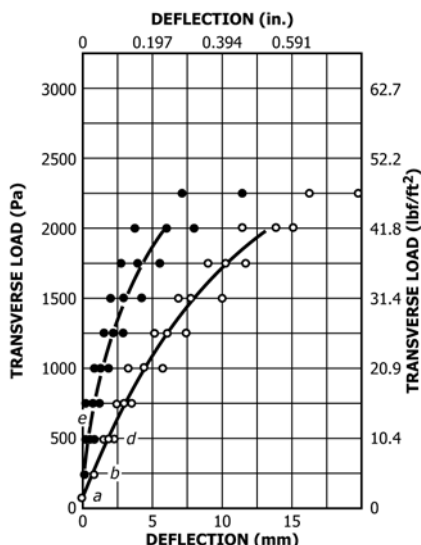

FIG. 1 Typical Graph Showing Results

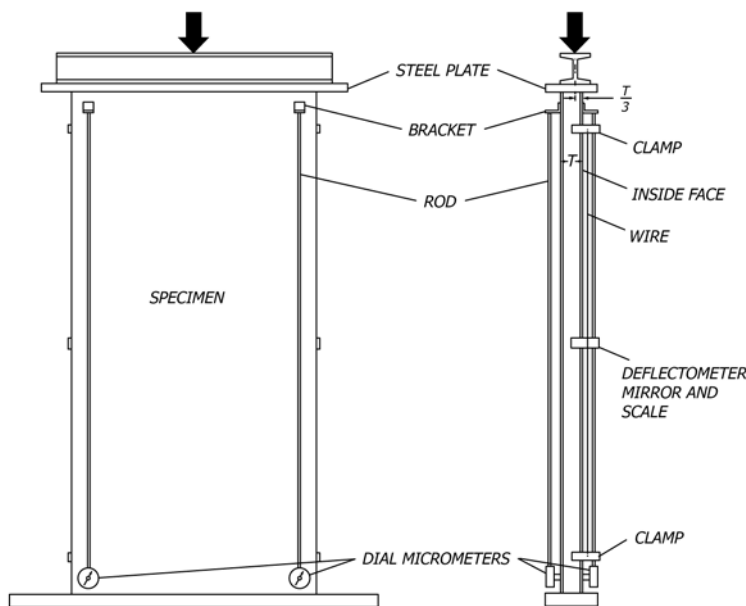

FIG. 2 Compressive Load Test on Wall Specimen

9.4.2 *Lateral Deflection*—Calculate the lateral deflection and the lateral set under each load for each deflectometer as the difference between the reading of the deflectometer when the load is applied and the initial reading. Calculate the lateral deflection and lateral set for the specimen as the average of the lateral deflection and lateral set of the two deflectometers.

9.4.3 *Data Presentation*—Record the maximum load for each specimen and report the results of load-deformation and load-deflection measurements in the form of a graph in accordance with Section 6. Report gage lengths of all deflection or deformation gages.

## 10. Tensile Load

10.1 *Test Specimens*—Tests shall be made on three like specimens, each having a height equal to the length of the element and a nominal width of 4 ft (1.2 m) (see Section 3).

10.2 *Apparatus*—The apparatus preferably shall be assembled in a vertical testing machine and shall conform to the detailed requirements for component parts prescribed in 9.2.1 and 9.2.2, or the equivalent, with the exception that the compressometers prescribed in 9.2.1 shall be replaced by extensometers which shall be like the compressometers but so adjusted before load is applied that the stretch of the specimen can be measured.

### 10.3 Procedure:

10.3.1 *Loading*—Test the specimen as a tension specimen by uniform application of tensile forces along the line of the fastenings at the top and the bottom of the wall in a building. The top and bottom pulling fixtures may be attached to the specimen by fastenings similar to those used in a building, provided that, under the maximum load, failure of the specimen occurs between the top and the bottom of the specimen, not in either the pulling fixtures or the fastenings. If, under the tensile load, failure occurs either in a pulling fixture or in a fastening, the results of the test determine only the properties

of the fixtures or the fastenings, not of the wall construction. When the failure occurs in fastenings, the tensile load indicates the maximum tensile strength of the construction that can be realized in actual service unless improved fastenings are provided.

10.3.1.1 *Masonry Constructions*—The construction may be continued upward beyond the top of the specimen and downward below the bottom of the specimen to enclose attachments for the pulling fixtures.

10.3.1.2 *Framed Wall Constructions*—If the construction has studs (either of wood or metal) the studs may be extended upward and downward beyond the top and bottom of the specimen and attached to the pulling fixtures. If the framed wall has plates at the top and the bottom, attach the pulling fixtures to the plates in the specimen.

10.3.2 *Load-Deformation Data*—Attach four extensometers to the faces of the specimen, one near each corner, as shown in Fig. 2, to measure the stretch of the specimen. Record the readings to the nearest 0.001 in. (0.025 mm).

10.3.3 *Lateral Deflection*—Attach two deflectometers, one to each edge of the specimen, as shown in Fig. 2. Record the readings, when the image of the wire coincides with the wire, to the nearest 0.01 in. (0.25 mm). Lateral deflection (if any) may be caused by nonaxial loading of the specimen.

10.4 *Calculations and Report*—For tensile loads, the calculations and report shall be similar to those required for compressive loads (see 9.4).

## 11. Transverse Load—Specimen Horizontal

11.1 *Test Specimens*—Tests shall be made on three like specimens on symmetrical assemblies and six like specimens on unsymmetrical assemblies, each having a length equal to the length of the element and a nominal width of 4 ft (1.2 m) (see Section 3).

11.2 *Apparatus*—The apparatus shall be assembled as shown in Fig. 3 and shall conform to the detailed requirements for component parts prescribed in 11.2.1 – 11.2.3, or the equivalent.

11.2.1 *Supports*—Two steel rollers with a steel plate between each supporting roller and the specimen.

11.2.2 *Loading Assembly*—Two steel rollers with a steel plate between each loading roller and the specimen.

11.2.3 *Deflection Gage*—A frame shall be placed on the upper face of the specimen. To prevent stresses deforming the frame as the specimen deforms under load, this frame shall rest on three hardened steel balls each supported by a steel block on the face of the specimen. Two of the balls shall be placed in a line vertically above one support and the third ball vertically above the other support. Two deflection—measuring devices, one near each longitudinal edge of the specimen, shall be attached to the frame at midspan. The spindles shall rest on the upper face of the specimen. The devices shall be graduated to 0.001 in. (0.025 mm) or less.

11.3 *Procedure:*

11.3.1 *Loading*—Use “two-point” loading for transverse load tests. Test the specimen as a simple beam (Fig. 3) on a span approximately 6 in. (150 mm) less than the specimen length. Apply two equal loads, each at a distance of one quarter of the span from the supports, toward the middle of the span. For wall specimens tested horizontally (Fig. 3), the load on the specimen shall include the weight of specimen between the supports. Apply the transverse loads to the outside face for three of the specimens and to the inside face for three of the specimens. For symmetrical assemblies, test only three specimens.

11.3.1.1 Uniformly distributed loading may be used instead of quarter-point loading, if a satisfactory method is available. The transverse strength for any span may be greater for some constructions under uniformly distributed load than under

loads applied at the quarter-points of the span. Transverse load, uniformly distributed, may be applied by air pressure, either in a bag or in a chamber having the specimen as one face. Support specimens tested under uniform loading by rollers as for quarter-point loading.

11.3.1.2 The bag method of loading is shown schematically in Fig. 4. Connect a reaction platform parallel to the face to be loaded and wider than the specimen to the supports by tie rods. Place an airtight bag of rubberized cloth as wide as the specimen and as long as the span between the specimen and the reaction platform. Apply transverse load to the specimen by increasing the air pressure in the bag. Measure the pressure by means of a manometer. Water is usually the liquid in the manometer, but the specific gravity of the liquid shall be such that the error in pressure readings does not exceed 1 %.

11.3.1.3 When the chamber method of loading is used with the specimen horizontal, place the specimen near the floor, which should be practically airtight. An airtight frame or curb shall surround the specimen closely and be about flush with the upper surface of the specimen. A rubber blanket covers the specimen, overlaps the frame, and is sealed so that it is reasonably airtight. Use a small vacuum pump or positive action exhaust blower to reduce air pressure between the specimen and floor. Measure the difference in pressure above and below the specimen by means of a manometer.

11.3.2 *Strength on Short Span*—The transverse strength of any construction increases as the span is shortened. If the strength of the construction for a shorter span is desired, do not compute it, but test the construction on the short span.

11.4 *Calculations and Report:*

11.4.1 *Load-Deflection Data*—For each micrometer, calculate the deflection under a given load as the difference between the reading to the nearest division of the micrometer when the load is applied and the initial reading. Calculate the deflection of the specimen for the span as the average of the deflections

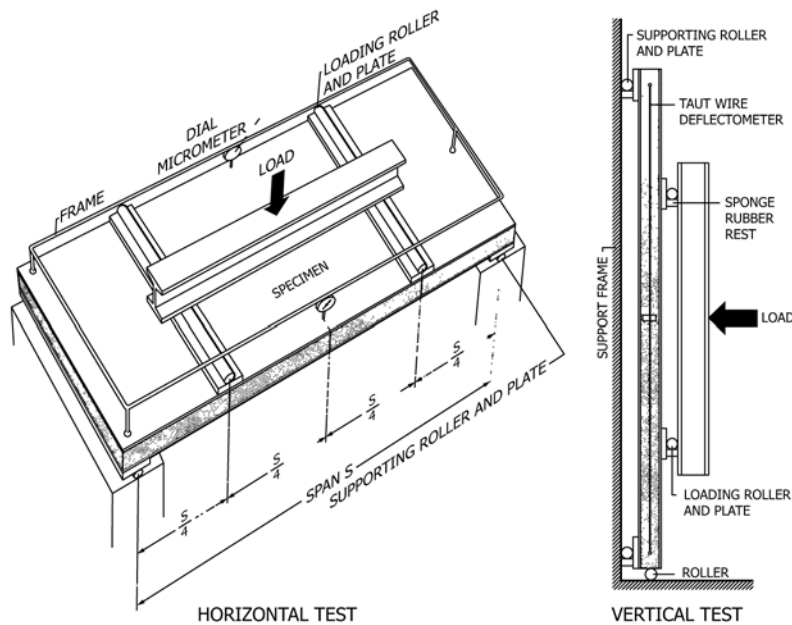

FIG. 3 Transverse Load Test on Wall Specimen

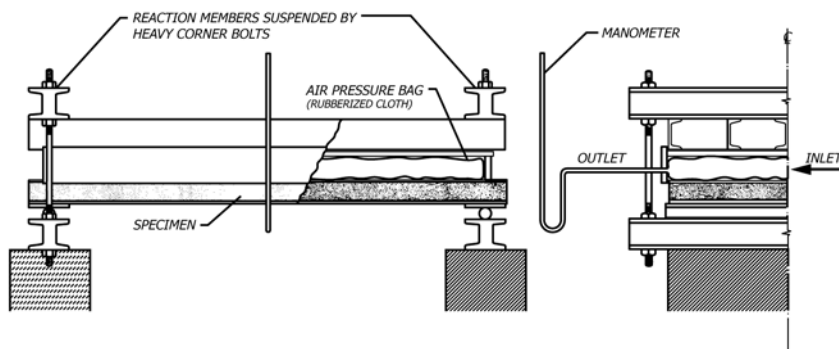

FIG. 4 Apparatus for Uniformly Distributed Transverse Load (Bag Method)

obtained from each of the two micrometers. Calculate the sets under the initial load by using a similar method. Record the maximum load for each specimen.

11.4.2 *Data Presentation*—Report the results in the form of a graph in accordance with Section 6.

## 12. Transverse Load—Specimen Vertical

12.1 *Test Specimens*—Tests shall be made on three like specimens on symmetrical assemblies and six like specimens on unsymmetrical assemblies each having a length equal to the length of the element and a nominal width of 4 ft (1.2 m) (see Section 3).

12.2 *Apparatus*—The apparatus shall be assembled as shown in Fig. 3 and shall conform to the requirements for component parts prescribed in 12.2.1 – 12.2.5, or the equivalent.

12.2.1 *Steel Channel*.

12.2.2 *Rollers*—Cylindrical rollers, two supporting rollers, two loading rollers.

12.2.3 *Screw Jack*.

12.2.4 *Ring Dynamometer*.

12.2.5 *Deflectometers*—Two taut-wire mirror-scale deflectometers similar to those described in 9.2.2.

12.3 *Procedure*—Transverse loads cannot be applied satisfactorily to some wall constructions, such as masonry, with the specimen in a horizontal position. For such constructions, apply the loads with the specimen in a vertical position, as shown in Fig. 3, thus simulating service conditions. The specimen, on a steel channel, shall rest on cylindrical rollers to prevent restrained end conditions. The axes of the rollers shall be parallel to the faces of the specimen. The two supporting rollers shall be in contact with the vertical surface of the frame and each roller shall rest horizontally on sponge rubber about 0.4 in. (10 mm) thick to prevent longitudinal restraint. Each of the two loading rollers shall also rest on sponge rubber. Apply the loads horizontally by a screw jack and measure by a ring dynamometer between the jack and the specimen. The error in the load indicated by the dynamometer shall not exceed 1%. Attach two taut-wire mirror-scale deflectometers to the specimen, one to each vertical edge.

12.3.1 Apply the transverse load to the outside face for three of the specimens, and to the inside face for three of the specimens. For symmetrical assemblies, test only three specimens.

12.3.2 The bag method of loading is shown schematically in Fig. 4. Connect a reaction platform parallel to the face to be loaded and wider than the specimen to the supports by tie rods. Place an airtight bag as wide as the specimen and as long as the span between the specimen and the reaction platform. Apply transverse load to the specimen by increasing the air pressure in the bag. Measure the pressure by means of a manometer or other pressure measuring device. The error of the pressure reading shall not exceed 1%.

12.3.3 When the Chamber Method of loading is used with the specimen vertical, the specimen forms one face of an airtight chamber from which the air is exhausted. If all four edges of the specimen bear on the chamber, this loading determines the strength of the specimen as a plate supported at the four edges, not the transverse strength as defined in these methods.

12.3.4 If a specimen tested by the chamber method, either horizontally or vertically, has an airtight cavity, vent each cavity to the low-pressure face by a hole in the face of the specimen not less than 0.2 in. (5 mm) in diameter, located where it will least affect the transverse strength of the specimen.

12.4 *Calculations and Report*—Calculate the results of test and report as described in 11.4, and report deflectometer readings to the nearest 0.01 in. (0.25 mm).

## 13. Concentrated Load

13.1 *Test Specimens*—Concentrated load tests shall be made on each transverse specimen after the transverse load tests, the concentrated load being applied to the same face to which the transverse load was applied.

13.2 *Apparatus*—The apparatus shall be assembled as shown in Fig. 5 and shall conform to the requirements for component parts prescribed in 13.2.1 – 13.2.3, or the equivalent.

13.2.1 *Steel Bar*—Steel bar having a diameter of 1 in. (25.4 mm) and the edge of the face contacting the specimen rounded to a radius of 0.05 in. (1.3 mm).

13.2.2 *Depth Gage*—The depth gage shall consist of a deflection—measuring device graduated to 0.001 in. (0.025 mm) or less mounted on a three-legged support. The support shall be notched to permit placing the device directly

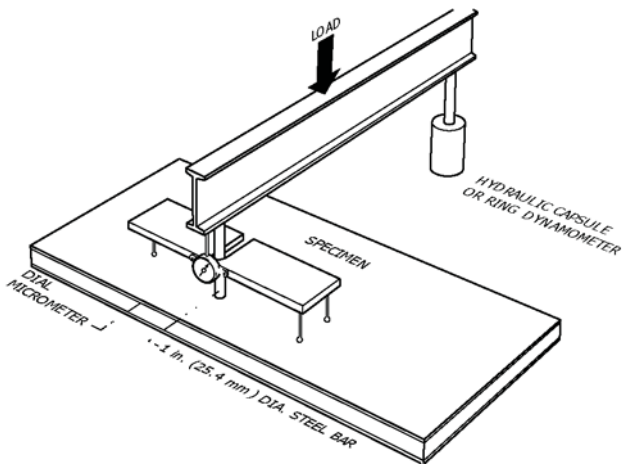

FIG. 5 Concentrated Load Test

adjacent to the bar and shall be long enough to permit placing the supporting legs on undisturbed areas of the face of the specimen.

13.2.3 *Loading Device*—Any convenient means for applying a compressive load up to 1100 lbf (5 kN) and means for measuring the load within 1 %.

13.3 *Procedure:*

13.3.1 *Loading*—Place the entire specimen or portion of the specimen on a horizontal support and properly level. Place the steel bar on the face of the specimen at what is judged to be the weakest place and, also, at what is judged to be the strongest place. Apply a load vertically downward to the upper surface of the bar. Continue loading until maximum load or 1000 lbf (4.45 kN) is attained.

13.3.2 *Depth of Indentation*—Measure the depth of indentation, by means of the depth gage, and record the reading of the micrometer to the nearest 0.001 in. (0.025 mm).

13.4 *Calculations and Report:*

13.4.1 *Depth of Indentation*—Calculate the depth of indentation (set) after a given load has been applied and the bar removed to the nearest 0.001 in. (0.025 mm) as the difference between the depth for that load and the initial reading of the micrometer before a load has been applied to the specimen.

13.4.2 *Data Presentation*—Report the results in the form of a graph in accordance with Section 6.

14. **Racking Load—Evaluation of Sheathing Materials on a Standard Wood Frame**

NOTE 2—These test methods have been used to evaluate design shear resistance of wall assemblies without the involvement of anchorage details. If the test objective is to measure the performance of the complete wall, Practice E564 is recommended.

14.1 *Scope*—This test method measures the resistance of panels, having a wood frame, and sheathed with sheet materials such as structural insulating board, plywood, gypsum board, transite, and so forth, to a racking load such as would be imposed by winds blowing on a wall oriented at 90° to the panel. It is intended to provide a reliable, uniform procedure for determining the resistance to racking load provided by these sheet materials as commonly employed in building

construction. Since a standard frame is employed, the relative performance of the sheathing is the test objective.

14.1.1 This test is conducted with standardized framing, loading procedures, and method of measuring deflection, as detailed in the method to ensure reproducibility. Provision is made for following the sheathing manufacturers' recommendations for attaching the sheathing to the frame, and for reporting the behavior of the specimen over its entire range of use.

14.1.2 In applying the results, due allowance shall be made for any variation in construction details or test conditions from those in actual service.

14.2 *Test Specimens:*

14.2.1 *Size and Number*—The test specimen shall be 8 ft by 8 ft (2.4 m by 2.4 m) and the framing shall be constructed as shown in Fig. 6 and a minimum of three panels of each construction shall be tested.

14.2.2 *Framing*—Frames shall be newly constructed for each test. All individual framing members shall be continuous.

14.2.2.1 *Sheathing Material Evaluation*—The frame shall be constructed as nearly like the frames shown in Fig. 6 as possible. No. 1 Douglas-fir Larch or Southern Pine lumber conforming to NIST Voluntary Product Standard PS20 shall be used. The stud spacing and size of the stud at the vertical panel joint shall be permitted to vary as necessary to reflect the manufacturer's specified test condition or standardized requirements. Any deviations from the framing scheme depicted in Fig. 6 shall be reported.

NOTE 3—A common situation where the 14.2.2.1 framing provisions apply would be for product qualification and evaluation of sheathing products where design values have already been established. In those instances, the sheathing performance and variation is the primary interest.

14.2.2.2 *Sheathing and Sheathing-to-Framing Attachment Design Shear Evaluation without the Involvement of Anchorage*—The framing shall be constructed in accordance with Fig. 6 except that the framing materials (size and specific gravity), stud spacing, and sheathing fastener size and spacing shall conservatively represent the range of applications that use the same design shear or racking resistance. The oven-dry specific gravity of the framing materials that receive perimeter sheathing fasteners at the panel boundaries and center stud shall be determined in accordance with Test Methods D2395 and reported. The average framing specific gravity for any test assembly shall not exceed the targeted average by more than 0.03.

NOTE 4—The framing details of 14.2.2.2 apply in instances where the racking test is used to evaluate the racking resistance of the sheathing and sheathing-to-framing attachment for the establishment of design values. This may include evaluation for sheathing, fastener, or framing products to be used in engineered or braced wall applications. In these instances, the goal is to ensure that the interaction between the framing, sheathing fastener, and sheathing is representative of the end use condition.

14.2.3 *Moisture Content*—The average moisture content of framing material shall be between 6 % and 15 % at the time of testing. Immediately after the racking test, the moisture content of all framing members that receive sheathing perimeter fasteners shall be determined using Test Methods D4442 or Practice D7438 and reported. Racking tests shall be conducted