



Designation: **E661–03 (Reapproved 2015)^{ε1} E661 – 22**

Standard Test Method for Performance of Wood and Wood-Based Floor and Roof Sheathing Under Concentrated Static and Impact Loads ¹

This standard is issued under the fixed designation E661; the number immediately following the designation indicates the year of original adoption or, in the case of revision, the year of last revision. A number in parentheses indicates the year of last reapproval. A superscript epsilon (ϵ) indicates an editorial change since the last revision or reapproval.

^{ε1} NOTE—Units information was editorially corrected in March 2015.

INTRODUCTION

During construction and occupancy of a building, floor and roof sheathing are subjected to concentrated loads that frequently govern the thickness required. Static loads may simulate either foot traffic, or loads from fixtures, when applied through loading disks of appropriate size. Impact loads will occur during construction and also in service.

Roof sheathing and subflooring are likely to be critical in strength or stiffness, or both, under foot traffic and construction loads, while single-layer floors are generally critical under fixture loads, foot traffic, and in-service impact loads. Subfloors, like single floors, must also support fixture loads, but they will have an additional layer of material, such as underlayment above, which will help to distribute concentrated loads.

(<https://standards.iteh.ai>)
Document Preview

1. Scope

1.1 This test method covers procedures for determining the resistance to deflection and damage of floor and roof sheathing used in site-built construction subjected to concentrated static loads as well as impact loads from nonrigid blunt objects. It is applicable to wood and wood-based panels and boards, but is not intended to cover profiled metal decks, nor precast or cast-in-place slabs. Surface indentation is not evaluated separately from deflection.

1.2 Three applications are covered: roof sheathing, subfloors, and single floors. Roof sheathing is tested in both a dry and a wet condition, while subfloors and single floors are both tested in a dry condition, as well as a condition of having dried out after being wet. These moisture conditions are those commonly experienced with site-built construction.

NOTE 1—Where it is anticipated that sheathing will be subjected only to dry conditions during construction and use, or else to greater moisture exposure than is indicated in 7.3.2, the corresponding exposure conditions may be modified by agreement between the interested parties. For example, shop-built construction may be tested dry only, although the possibility of exposure to high humidity or leaks and flooding during use should be considered.

1.3 The values stated in inch-pound units are to be regarded as standard. The values given in parentheses are mathematical conversions to SI units that are provided for information only and are not considered standard.

1.4 *This standard does not purport to address all of the safety concerns, if any, associated with its use. It is the responsibility of the user of this standard to establish appropriate safety, health, and environmental practices and determine the applicability of regulatory limitations prior to use.*

¹ This test method is under the jurisdiction of ASTM Committee E06 on Performance of Buildings and is the direct responsibility of Subcommittee E06.11 on Horizontal and Vertical Structures/Structural Performance of Completed Structures.

Current edition approved March 1, 2015 Oct. 1, 2022. Published March 2015 October 2022. Originally approved in 1978. Last previous edition approved in 2009 2015 as E661 – 03 (2009) (2015)^{ε1}. DOI: 10.1520/E0661-03R15E01-10.1520/E0661-22.

1.5 This international standard was developed in accordance with internationally recognized principles on standardization established in the Decision on Principles for the Development of International Standards, Guides and Recommendations issued by the World Trade Organization Technical Barriers to Trade (TBT) Committee.

2. Referenced Documents

2.1 ASTM Standards:²

[D1517 Terminology Relating to Leather](#)

[E575 Practice for Reporting Data from Structural Tests of Building Constructions, Elements, Connections, and Assemblies](#)

[E631 Terminology of Building Constructions](#)

2.2 ~~Other Standards~~ Standard:³

~~[Fed. Spec. V-T-291E\(1\)](#)~~ [Fed. Spec. A-A-50197A Linen, Thread](#)

3. Terminology

3.1 See Terminology [E631](#) for terms related to this standard.

4. Summary of Test Method

4.1 Roof and floor sheathing specimens are subjected to concentrated loads applied through a ~~3-in. (76-mm)~~ 3 in. (76 mm) or a ~~1-in. (25-mm)~~ 1 in. (25 mm) diameter loading disk, depending on the intended use and the properties to be evaluated. They are also subjected to the impact of a shot-filled drop bag. Specimens are tested in a horizontal position, mounted on fully supported framing members and with loads applied to the top surface near an edge, or at a location determined to be more vulnerable. Any support framing may be used that is representative of the anticipated service, as the framing is not considered a major test variable.

5. Significance and Use

5.1 The procedures outlined will provide data that can be used to evaluate the structural performance, under concentrated loads, of roof and floor sheathing, separate from the effects of the framing, under simulated conditions representative of those in actual service.

5.2 The procedures are intended to be applied to roof or floor sheathing materials installed directly to framing. They are not intended for the evaluation of the framed assembly as a whole.

6. Apparatus

6.1 *Concentrated Load*—The apparatus for the concentrated load test shall conform to the following requirements (see [Fig. 1](#)):

6.1.1 *Supports*—The framing members shall be supported in order not to deflect under the applied loads. The support system shall include provisions for rigidly restraining the ends of the framing members, as with blocking and clamps, to prevent rotation or vertical movement during testing.

6.1.2 *Loading Device*—Any convenient means may be used for applying a compressive load up to ultimate, and for measuring the load within $\pm 1\%$ accuracy. Load shall be applied through a ball-and-socket joint to assure even application.

6.1.3 *Loading Disks*—Two steel disks are required, one having a diameter of 1 in. (25 mm), representing a concentrated load, and one of 3 in. (76 mm) representing foot traffic, each with a thickness of at least 0.50 in. (13 mm). The edge of the loading disk contacting the test specimen shall be rounded to a radius not exceeding 0.06 in. (1.5 mm).

6.1.4 *Deflection Gage*, mounted on a rigid tripod whose legs rest on the sheathing immediately above the framing members that are adjacent to the load point ([Fig. 1](#)). The deflection gage should have a range exceeding the maximum anticipated deflection, have a maximum error of $\pm 1\%$, and be graduated to 0.001 in. (0.02 mm).

² For referenced ASTM standards, visit the ASTM website, www.astm.org, or contact ASTM Customer Service at service@astm.org. For *Annual Book of ASTM Standards* volume information, refer to the ~~standard's~~ Document Summary page on the ASTM website.

³ Available from ~~DLA Document Services, Building 4/D, 700 Robbins Avenue, Philadelphia, PA 19111-5094, <http://quicksearch.dla.mil>~~ U.S. General Services Administration, 1800 F Street, NW Washington, DC 20405, <https://fedspecs.gsa.gov>.

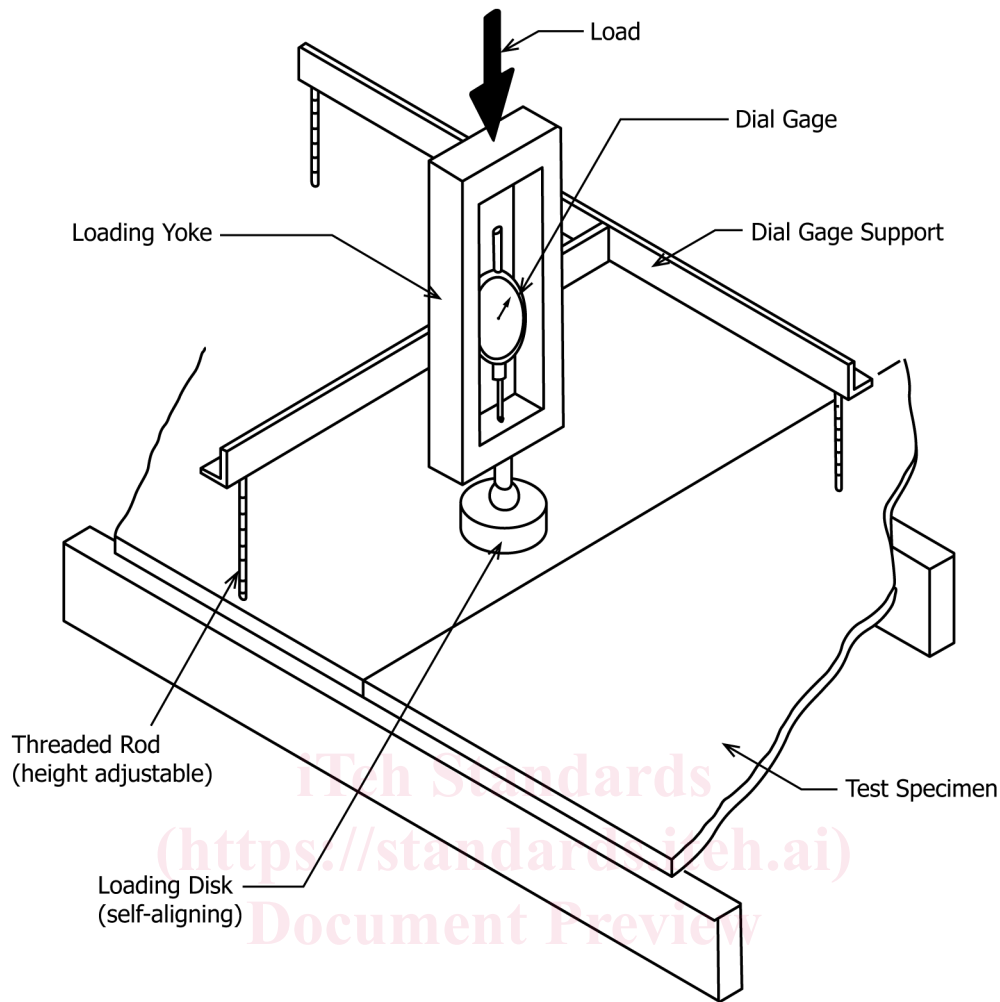

FIG. 1 Concentrated Static Load Apparatus

6.2 *Impact Load*—The apparatus for the impact load test shall conform to the requirements of 6.1.1 – 6.1.4. In addition, the following equipment shall be used:

6.2.1 *Drop Bag*—The bag shall be constructed as in 6.2.1.1 – 6.2.1.3 (see Fig. 2).

6.2.1.1 *Leather*—The leather used in construction of the bag shall be harness leather (oak tanned from packer hides) or latigo leather (alum and vegetable tanned), or both. It shall be selected from a back or a side to contain enough area of the required thickness. Leather thickness shall be expressed in ounces (1 oz = 1/64 in. (0.4 mm)). The above terms are explained in Terminology D1517.

6.2.1.2 *Thread*—Thread used to fabricate the bag shall be linen, of four or more plies, meeting the requirements for Type B₇II, Class 1 or 2, of Fed. Spec. V-T-291E(1)-Fed. Spec. A-A-50197A.

6.2.1.3 *Fabrication*—The bag shall be 28 in. (710 mm) high by 29 in. (735 mm) in circumference, with a sidewall of 8-oz leather 1/8 in. (3 mm) thick. The vertical edges shall be sewn together flesh side out and the seam shall be reinforced with a piece of 8-oz leather overlapping 3/8 in. (9 mm) on each side. The side shall then be turned hair side out and sewn to the bottom. The base (bottom disk) shall be 9 1/2 in. to 10 1/2 in. (230(230 mm) to 265 mm) in diameter of 12-oz leather 3/16 in. (5 mm) thick. The seam attaching the sidewall to the base shall be 1/4 in. (6 mm) from the edge of the base. Two rows of stitching shall be used for the vertical sidewall seam and the seam attaching the sidewall to the base.

(1) The strap to hoist the bag shall be made from 8-oz leather 1/8 in. (3 mm) thick by 5/8 in. (16 mm) wide by 24 in. (610 mm) long. The strap shall be passed through holes, diametrically opposite, in the sidewalls 1 1/2 in. (40 mm) from the top of

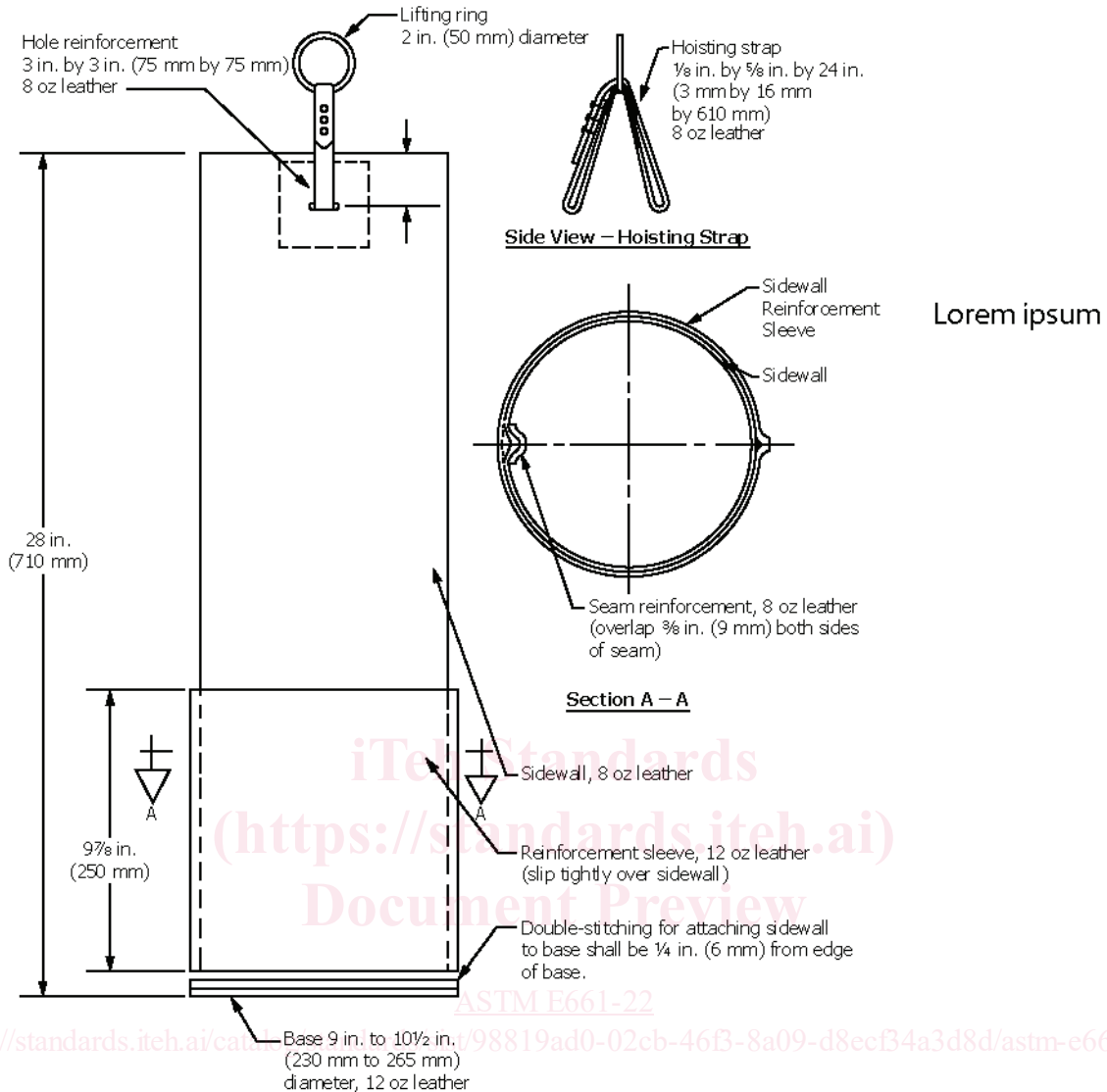

Lorem ipsum

iTech Standards
(https://standards.iteh.ai)
Document Preview

ASTM E661-22

https://standards.iteh.ai/catalog/standards/astm/98819ad0-02cb-46f3-8a09-d8ecf34a3d8d/astm-e661-22

(1) **Leather**—Use harness leather (oak-tanned from packer hides) or latigo leather (alum and vegetable tanned) (see Terminology D1517 for definitions of terms) (1 oz leather = 1/64 in. (0.4 mm) thick).

(1) **Leather**—Use harness leather (oak-tanned from packer hides) or latigo leather (alum and vegetable tanned) (see Terminology D1517 for definitions of terms) (1 oz leather = 1/64 in. (0.4 mm) thick).

(2) **Thread**—Use linen thread (minimum four-ply) in accordance with Fed. Spec. A-A-50197A, Type II, Class 1 or 2. Double-stitch sidewall seam and seam attaching sidewall to base.

(3) **Metal Shot**—Use shot (0.039 in. to 0.138 in. (1 mm to 3.5 mm) diameter). Fill bag with shot and cover with two layers of 3 in. (76 mm) foam rubber. Adjust total weight of assembly to 30 lb (13.6 kg) ± 1/2 %, or more, when specified (see 6.2.1.4).

(2) **Thread**—Use linen thread (minimum four-ply) in accordance with Fed. Spec. V-T-291E(1), Type B, Class 1 or 2. Double-stitch sidewall seam and seam attaching sidewall to base.

(3) **Metal Shot**—Use shot (0.039 to 0.138 in. (1 to 3.5 mm) diameter). Fill bag with shot and cover with two layers of 3 in. (76 mm) foam rubber. Adjust total weight of assembly to 30 lb (13.6 kg) ± 1/2 %, or more, when specified (see 6.2.1.4).

FIG. 2 Leather Drop Bag Assembly

the wall. These holes shall be reinforced with pieces of 8-oz 8 oz leather 3 in. (76 mm) square. The leather strap shall be passed twice through a 2-in. (50-mm) 2 in. (50 mm) diameter lifting ring and the ends fastened by sewing, riveting, or by use of a buckle.

(2) To avoid excessive stretching of the leather sidewall or failure of the vertical seam, a sleeve, made from 12-oz 12 oz leather, of the same type as the base of the bag, shall be fitted to slip tightly over the lower portion of the bag. This sleeve should be 9 7/8 in. (250 mm) high.

6.2.1.4 **Shot**—The bag shall be loosely filled with metal shot or pellets with diameters of 0.039 0.039 in. to 0.138 in. (1 mm to 3.5 mm). Two layers of 3-in. (76-mm) 3 in. (76 mm) thick foam rubber or similar padding shall be placed over the metal shot to prevent spillage during testing. Adjust the total weight of the drop bag and metal shot to the weight specified in Table 1, ± 1/2 %.

TABLE 1 Drop Bag Weights for Impact Load Tests

Sheathing Span, <i>S</i>	Total Weight of Drop Bag (Including Shot), lb (kg)
$S \leq 24$ in. (610 mm)	30 (13.6)
24 in. (610 mm) < $S \leq 48$ in. (1220 mm)	60 (27.3)
$S > 48$ in. (1220 mm)	^A

^A See 6.2.1.4.

This value shall be verified before impact tests are conducted. For spans greater than 48 in. (1220 mm), the weight of the drop bag shall be as agreed upon between the interested parties.

6.2.2 *Measuring Rod*—A measuring rod, graduated in ~~6-in. (152-mm)~~ 6 in. (152 mm) increments and equipped with a sliding pointer, shall be used to measure the drop height of the bag.

7. Test Specimens

7.1 Select specimens that are representative of the product being evaluated, both in accordance with the inherent structural properties, including density, and in accordance with the thickness and thickness tolerances characteristic of the product. Unless otherwise specified, the number of tests shall be such as to develop the desired confidence level for each property measured, but conduct at least ten tests as a minimum for each test condition evaluated.

NOTE 2—A specimen can usually be made from a single panel, or assembled from a number of boards (see Figs. 3 and 4).

7.2 Specimen Size:

7.2.1 *Length*—The specimen length perpendicular to the main framing members shall conform to the center-to-center spacing, *S*, anticipated in service (Figs. 3 and 4). Where sheathing is continuous over more than one span, its length shall be equal to the minimum number of spans permitted or recommended for the product used and its intended application, multiplied by the center-to-center spacing of the framing members.

7.2.2 *Width*—The specimen width shall be at least ~~23½ in.~~ in. (595 mm). The specimen width shall conform to its nominal width when edges are fully supported. When edges are unsupported or partially supported, sheathing may be trimmed to a width not less than 23½ in. (595 mm).

7.2.3 *Thickness*—Measure and report thickness of all sheathing specimens after conditioning in accordance with 7.3.1 and report.

7.2.4 Cut the sheathing to the required size prior to conditioning.

7.3 *Conditioning of Sheathing*—Prior to static and impact testing, subject sheathing to wetting and drying to simulate possible typical construction conditions. Test sheathing intended for roof applications under both dry and wet conditions, as described in 7.3.1 and 7.3.2. Test sheathing intended for subfloor or single-layer floor application both dry and in a re-dried condition after exposure to wet conditions, in accordance with 7.3.1 and 7.3.3. This sheathing may also be tested under wet conditions in accordance with 7.3.2 (see Note 1).

7.3.1 *Dry Tests*—Condition sheathing to either constant weight or moisture content or for at least 2 weeks, at ~~68±6 °F~~ 68±6 °F ± 6°F (20±3 °C) and ~~65±5 %~~ 65±5 % ± 5 % relative humidity.

7.3.2 *Wet Tests*—Expose sheathing to a continuous water spray for 3 days, applied to the top surface of the sheathing at a rate such as to keep this surface continuously wet. Position the sheathing so as to preclude water ponding on it, or immersion of any portion.

NOTE 3—A simplified spray tank may be used to support the sheathing in an approximately vertical position during exposure to the water spray. The tank should be fitted with drains so that water spray does not accumulate, and the sheathing should be placed on blocks to elevate its lower edge above the residual water in the tank bottom.

7.3.3 *Re-dried Tests*—Expose sheathing to the 3-day water spray in accordance with 7.3.2 and then dry in accordance with 7.3.1.

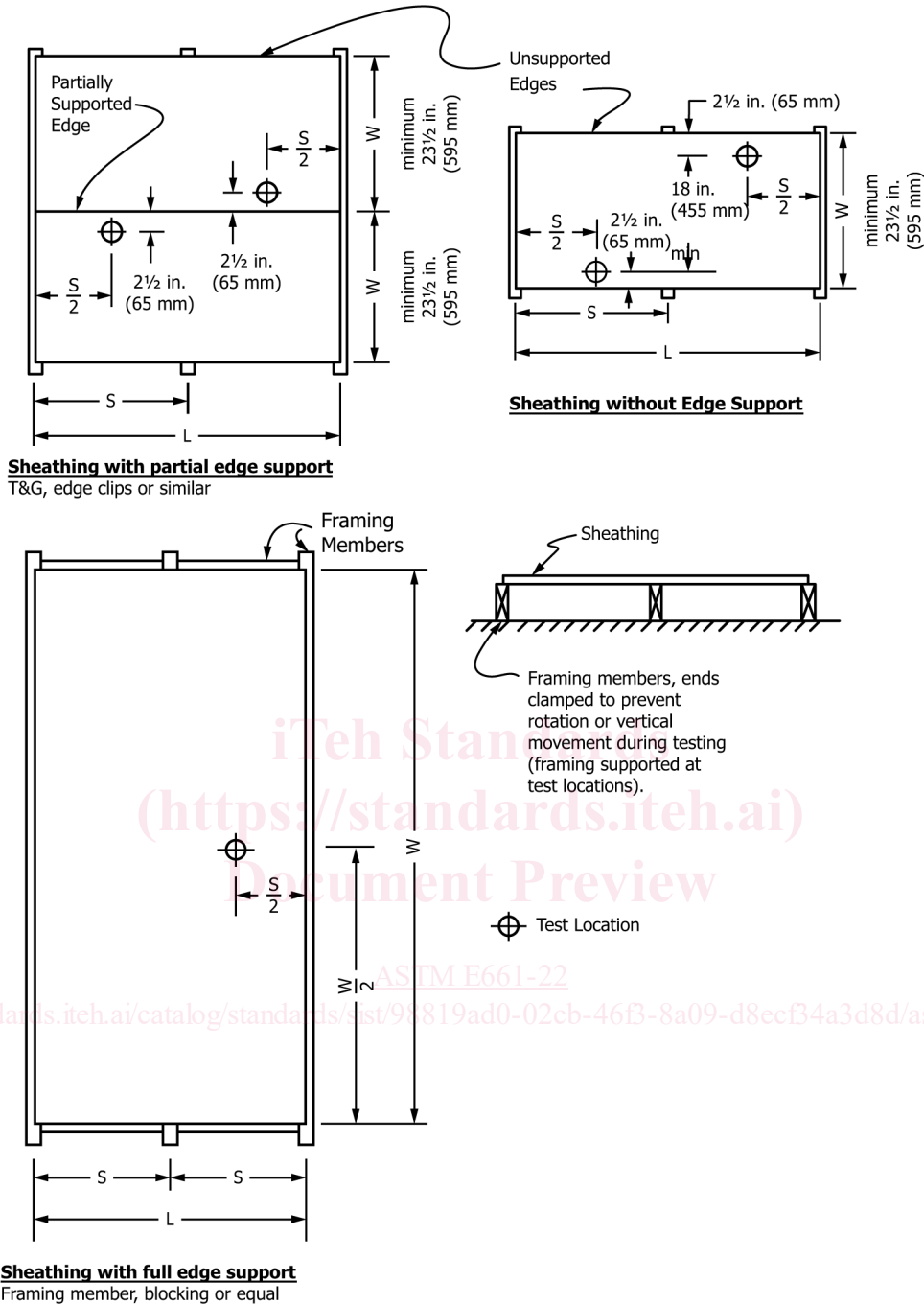

FIG. 3 Concentrated Static Load Test Specimens

7.4 *Fabrication of Test Specimens*—Install the conditioned sheathing on framing as shown in Figs. 3 and 4, using the type of framing, fastener schedule, and installation details as planned for use in service; consider this a part of the test conditions. After fabrication, test specimens promptly at ambient laboratory conditions.

NOTE 4—Where sheathing is installed on wood framing, the framing may be of any species and grade commonly used in construction that has a specific gravity of 0.40 to 0.55, oven-dry basis, with a maximum moisture content of 19 %. If nails are used, they may be double-headed to simplify disassembly of the specimen upon completion of testing, providing such nails will not damage the testing equipment. Framing may be reused for more than one test, provided it has not been significantly damaged by previous testing.

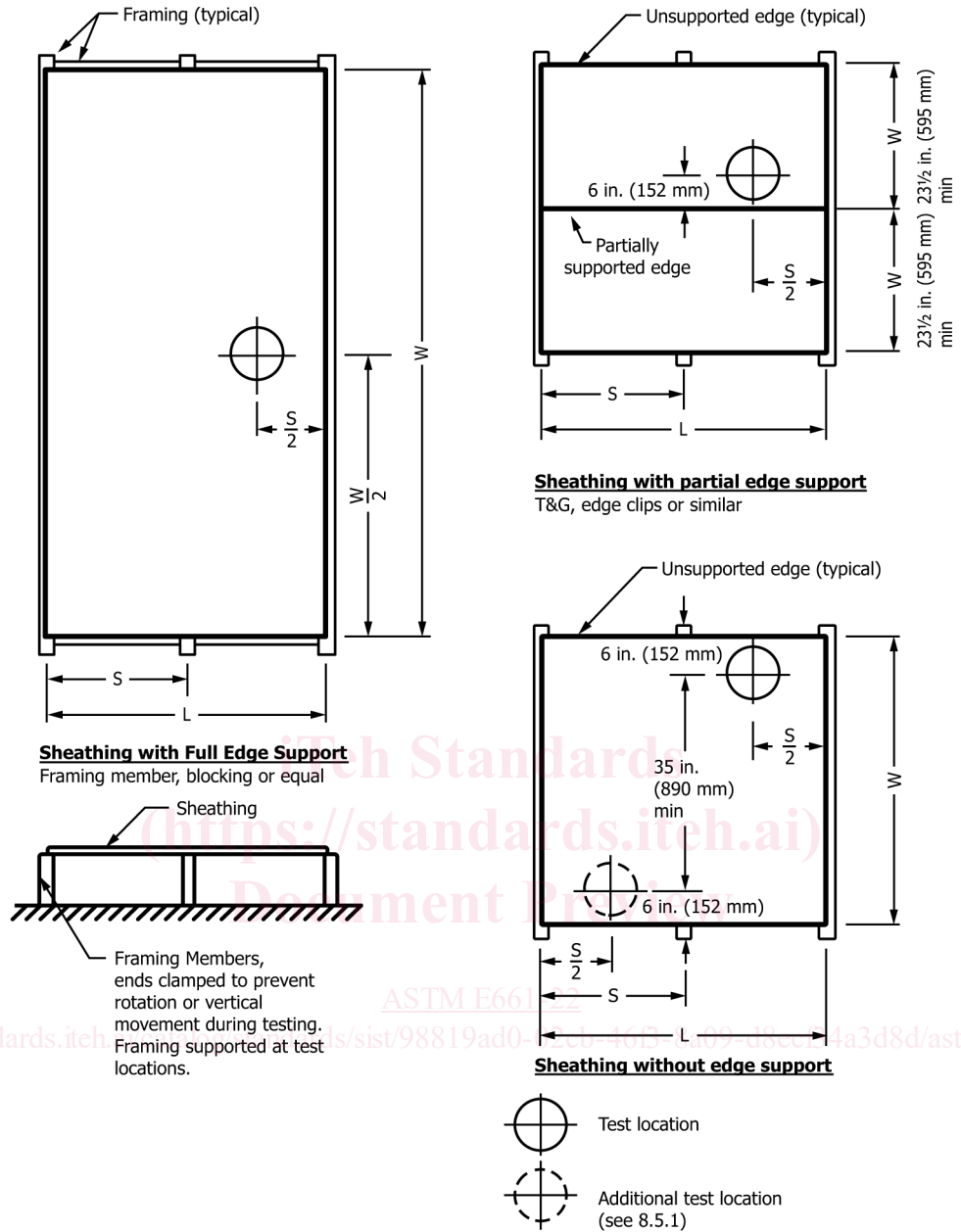

FIG. 4 Impact-Load Test Specimens

8. Procedure

8.1 *Concentrated Static Load Tests*—Apply the concentrated static load at one location on the top surface of the sheathing, midway between framing members (see Fig. 3).

8.1.1 If the edge of the sheathing is fully supported between main framing members, apply the concentrated load at midwidth. If the edge is unsupported, or partially supported, as with clips or a tongue and groove joint, apply the load 2½ in. (65 mm) in from the unsupported or partially supported edge as shown in Fig. 3.

8.1.2 Specimens may be used for more than one test provided the test locations are at least 18 in. (455 mm) apart (measured parallel to the framing), occur in different spans, and show no sign of damage from other tests.

8.2 *Stiffness*—Measure deflection relative to framing under the load point, using the 3-in. (76 mm) diameter loading disk.