



Designation: **E2322–03 (Reapproved 2015) E2322 – 22**

Standard Test Method for Conducting Transverse and Concentrated Load Tests on Panels used in Floor and Roof Construction¹

This standard is issued under the fixed designation E2322; the number immediately following the designation indicates the year of original adoption or, in the case of revision, the year of last revision. A number in parentheses indicates the year of last reapproval. A superscript epsilon (ϵ) indicates an editorial change since the last revision or reapproval.

1. Scope

1.1 This test method covers the following procedures for determining the structural properties of segments of floor and roof constructions:

	Section
Test Specimens	5
Loading	6
Deformation Measurements	7
Report	8
Precision and Bias	9
Testing Floors	
Transverse Load	10
Concentrated Load	11
Testing Roofs	
Transverse Load	12
Concentrated Load	13

1.2 This test method serves to evaluate the performance of floors and roofs panels subjected to (1) Uniform loading, and (2) Concentrated static loading, which represent conditions sustained in the actual performance of the element. The standard is not intended for the evaluation of individual structural framing or supporting members (floor joist, rafters, and trusses), or both.

1.3 The text of this standard references notes and footnotes which provide explanatory material. These notes and footnotes, excluding those in tables and figures, shall not be considered as requirements of the standard.

1.4 This standard is not intended to cover concrete floor slabs.

1.5 The values stated in SI units are to be regarded as standard. No other units of measurement are included in this standard.

1.6 *This standard does not purport to address all of the safety concerns, if any, associated with its use. It is the responsibility of the user of this standard to establish appropriate safety, health, and environmental practices and determine the applicability of regulatory limitations prior to use.*

1.7 *This international standard was developed in accordance with internationally recognized principles on standardization established in the Decision on Principles for the Development of International Standards, Guides and Recommendations issued by the World Trade Organization Technical Barriers to Trade (TBT) Committee.*

¹ This test method is under the jurisdiction of ASTM Committee E06 on Performance of Buildings and is the direct responsibility of Subcommittee E06.11 on Horizontal and Vertical Structures/Structural Performance of Completed Structures.

Current edition approved March 1, 2015; October 1, 2022. Published March 2015; October 2022. Originally approved in 2003. Last previous edition approved in 2009 as E2322 – 03 (2009); (2015). DOI: 10.1520/E2322-03R15; 10.1520/E2322-22.

2. Referenced Documents

2.1 *ASTM Standards*:²

- ~~C109/C109M Test Method for Compressive Strength of Hydraulic Cement Mortars (Using 2-in. or [50 mm] Cube Specimens)~~
- ~~E4 Practices for Force Calibration and Verification of Testing Machines~~
- ~~E72 Test Methods of Conducting Strength Tests of Panels for Building Construction~~
- ~~E73 Practice for Static Load Testing of Truss Assemblies~~
- ~~E196 Practice for Gravity Load Testing of Floors and Low Slope Roofs~~
- ~~E455 Test Method for Static Load Testing of Framed Floor or Roof Diaphragm Constructions for Buildings~~
- ~~E575 Practice for Reporting Data from Structural Tests of Building Constructions, Elements, Connections, and Assemblies~~
- ~~E631 Terminology of Building Constructions~~
- ~~E661 Test Method for Performance of Wood and Wood-Based Floor and Roof Sheathing Under Concentrated Static and Impact Loads~~
- ~~E695 Test Method of Measuring Relative Resistance of Wall, Floor, and Roof Construction to Impact Loading~~
- ~~E1592 Test Method for Structural Performance of Sheet Metal Roof and Siding Systems by Uniform Static Air Pressure Difference~~

3. Terminology

3.1 *Definitions*—Refer to Terminology [E631](#) for definitions of terms used in these test methods.

4. Significance and Use

4.1 *Transverse Load*—The procedures outlined will serve to evaluate the performance of floor and roof segments for deflection, permanent set and ultimate capacity. Performance criteria based on data from these procedures can ensure structural adequacy and effective service.

4.2 *Concentrated Load*—This concentrated load test shall be used to evaluate surface indentation of structural framing members.

4.3 These procedures will serve to evaluate performance of roof and floor segments under simulated service conditions. Diaphragm shear loading of roof and floor segments shall be evaluated under Test Method [E455](#). Impact loading shall be evaluated under Test Methods [E661](#) or [E695](#).

5. Test Specimens

5.1 *Specimens*—There shall be at least three replicate specimens for each test. Specimens shall be constructed to represent sections of the floor, or roof assembly including the means of the attachment when the load direction is away from the supports. The specimens shall be representative in width and length as to the material and workmanship. The test specimen shall not be less than the width and length of the tributary load area under actual conditions. If the tributary load area for the test specimen exceeds the test equipment, a reduced specimen that is representative in proportional width and length shall be tested. Unsymmetrical assemblies shall be tested in each axis. If the structural properties of a particular construction are to be compared with another construction, widths of the specimens shall be of comparable size.

5.2 *Age*—Constructions, which include concrete and masonry for which the structural properties depend upon the age of the specimen, shall be aged not less than what is indicated by the manufacturer or national standard, or both. The age of the specimen shall be recorded in the report.

6. Loading

6.1 *Apparatus*—The testing machine or load-measuring apparatus shall comply with the requirements prescribed in Practices [E4](#).

6.2 *Application of Load*—Apply the load to each individual specimen in increments so that a sufficient number of readings will be obtained to determine definitely the load-deformation curve (see [6.3](#)) using the following sequence:

² For referenced ASTM standards, visit the ASTM website, www.astm.org, or contact ASTM Customer Service at service@astm.org. For Annual Book of ASTM Standards volume information, refer to the [standard's Document Summary](#) page on the ASTM website.

6.2.1 Prior to testing, apply a small initial load not greater than 5 % of the ultimate capacity load expected and hold for 5 min (± 1 min) and then release. Zero all measuring devices and begin the test.

6.2.2 Record the initial load and deformation reading of the specimen and then increase the load on the specimen to the first predetermined increment.

6.2.3 Record the load and deformation reading and release the load back to the initial load and then record the set of the specimen.

6.2.4 Increase the load to the next predetermined increment and record the information as indicated in the first load increment above. Follow this sequence of loading and reading for all predetermined load increment(s).

6.3 *Duration of Load Application*—After each increment of load is applied, maintain the load level as constant as possible for a period of 5 min (see **Note 1**). Take deformation readings as soon as practical after load application, at the end of the 5-min period under constant load, and immediately and at the end of the 5-min period after any partial or complete load release. Plot initial and 5-min readings in the form of load-deformation curves. Maintain complete load-deformation time records throughout the test. If application of a given load is required for a certain period, such as 24 h, take deformation readings at the end of this period, to allow the satisfactory plotting of a time-deformation curve for the complete period.

NOTE 1—Reason for the 5-min application of constant-level increment loads are as follows:

(1) To permit the assembly to come to a substantial rest prior to taking the second set of readings. (Depending on the method employed for applying the test load, it may be necessary to continue, at a reduced rate, the motion of the loading device in order to maintain the constant load level during the 5-min period.)

(1) To permit the assembly to come to a substantial rest prior to taking the second set of readings. (Depending on the method employed for applying the test load, it may be necessary to continue, at a reduced rate, the motion of the loading device in order to maintain the constant load level during the 5-min period.)

(2) To observe any time-dependent deformation or load redistribution, or both, and to record accurately the load level when time-dependent deformation starts, that is, at the divergence of the immediate and delayed load-deformation curves. This load level may, under certain conditions, have an important bearing on the design load.

(3) To be able to stop the test, if this should be desirable, prior to total failure, after initial failure has been anticipated as a result of the observations.

(4) To assure uniformity in test performance and consistency in test results.

~~(2) To observe any time-dependent deformation or load redistribution, or both, and to record accurately the load level when time-dependent deformation starts, that is, at the divergence of the immediate and delayed load-deformation curves. This load level may, under certain conditions, have an important bearing on the design load.~~

~~(3) To be able to stop the test, if this should be desirable, prior to total failure, after initial failure has been anticipated as a result of the observations.~~

~~(4) To assure uniformity in test performance and consistency in test results.~~

7. Deformation Measurements

7.1 Measure the deformations with sufficient precision to define the load-deformation relationship, and report at least to the nearest 0.25 mm.

8. Report

8.1 Prepare the report in accordance with Recommended Practice **E575**.

9. Precision and Bias

9.1 It is not possible to specify the precision of the procedure in this standard for measuring these test methods because of the variety of materials and combinations of materials involved.

TESTING FLOORS

10. Transverse Load—Floor

10.1 *Test Specimen(s)*—Test specimen(s) shall be constructed in accordance with Section **5**.

10.2 *Apparatus*—The apparatus shall be capable of applying a uniform load (such as air bag load or vacuum load), gravity load or two point load and shall conform to the requirements prescribed in **10.2.1** through **10.2.3** or the equivalent.

10.2.1 *Uniform Load*—Uniformly distributed loading is a satisfactory test method. Uniformly distributed load shall be applied by air pressure, either in a bag or in a vacuum chamber.

10.2.1.1 The bag method of loading is schematically shown in Fig. 1. Connect a reaction platform parallel to the face to be loaded and wider than the specimen to the supports by tie rods. Place an airtight bag as wide as the specimen and as long as the span between the specimen and the reaction platform. Apply transverse load to the specimen by increasing the air pressure in the bag. Measure the difference in pressure by means of a manometer or other pressure measuring device. The error of the pressure reading shall not exceed 1 % of the full-scale reading. Deflection measurement shall be measured following 10.4. See Fig. 1.

10.2.1.2 When the vacuum chamber method of loading is used, place the specimen near the test frame to create an airtight vacuum chamber. An airtight frame or curb shall surround the specimen closely and be flush with the upper surface of the specimen. An air resistant blanket covers the specimen, overlaps the frame, and is sealed so that it is reasonably airtight. Use a vacuum pump or positive action exhaust blower to reduce air pressure between the specimen and floor/wall. Measure the difference in pressure by means of a manometer or other pressure measuring device. The error of the pressure reading shall not exceed 1 % of the full scale reading. Deflection measurement shall be conducted following 10.4. See Fig. 2.

10.2.2 *Gravity Load*—Gravity load testing shall be conducted in accordance with Practice E196.

10.2.3 *Two Point Load*—The two point (quarter-point) loading method is used for transverse load tests. Test the specimen as a simple beam (Fig. 3) on a span 150 mm less than the specimen length. Apply two equal loads, each at a distance of one-quarter of the span from the supports, toward the middle of the span. For floor specimens tested horizontally (Fig. 1), the load on the specimen shall include the weight of the specimen between the supports. Apply the transverse loads to the upper (finish floor) face for three of the symmetrical specimens. For asymmetrical assemblies, the bottom face for three of the specimens must also be tested. Deflection measurements shall be measured following 10.4. See Fig. 3.

10.3 *Loading Application*—The application of load is found in 6.2. The application of load shall be compatible with the test apparatus indicated in 10.2.

10.4 *Deflection Measurement Device*—The deflection measurement device shall be compatible with the test apparatus indicated in 10.2. A frame shall be placed on the upper face of the specimen in a manner such that the frame shall not deform as the specimen deforms under load. Two deflection measuring devices, one near each longitudinal edge of the specimen, shall be attached to the frame at the mid span.

10.4.1 *Method A—Deflection Measuring Device Top of Panel*—Mid span deflection shall be measured on the top of the panel. The deflection measurement should be referenced to the panel deflection at the end supports.

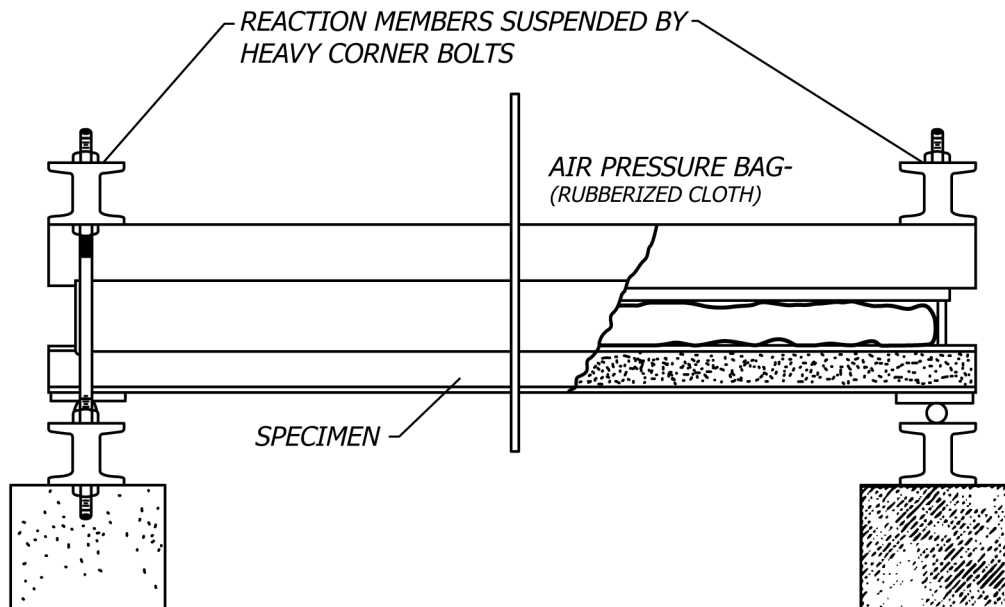

FIG. 1 Apparatus for Uniformly Distributed Transverse Load (Bag Method)

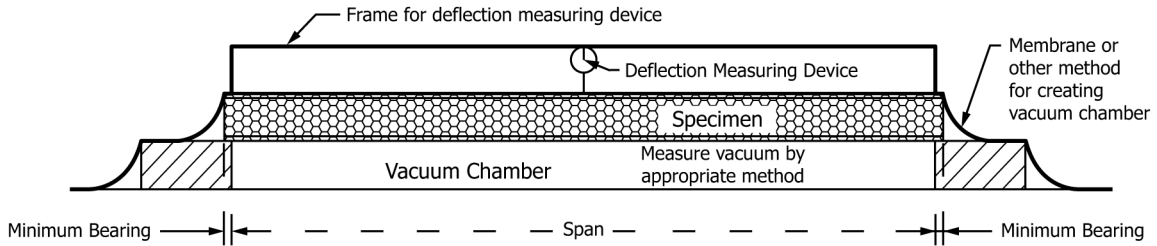

FIG. 2 Apparatus for Uniformly Distributed Transverse Load (Vacuum Bag)

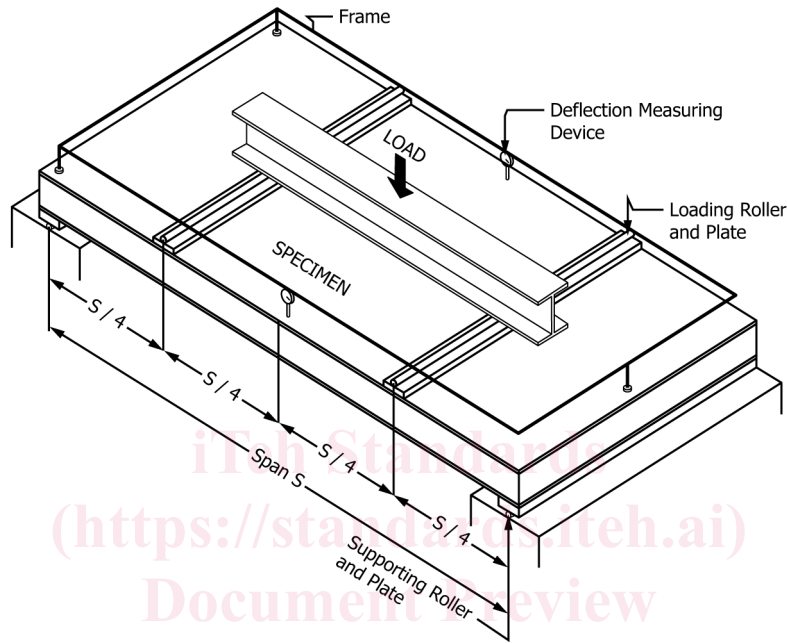

FIG. 3 Quarter Point Loading

ASTM E2322-22

<https://standards.iteh.ai/catalog/standards/sist/34289adb-b32c-4f72-a450-769e931f01e6/astm-e2322-22>

10.4.2 Method B—Deflection Measuring Device Bottom of Panel—Mid span deflection shall be measured on the bottom of the panel. The deflection measurement should be referenced to the panel deflection at the end supports.