



Designation: C201 – 93 (Reapproved 2019)<sup>ε1</sup>

## Standard Test Method for Thermal Conductivity of Refractories<sup>1</sup>

This standard is issued under the fixed designation C201; the number immediately following the designation indicates the year of original adoption or, in the case of revision, the year of last revision. A number in parentheses indicates the year of last reapproval. A superscript epsilon ( $\epsilon$ ) indicates an editorial change since the last revision or reapproval.

<sup>ε1</sup> NOTE—The conductivity factor in parentheses in 1.1 was corrected editorially from 2818 W/m·K to 28.8 W/m·K in October 2022.

### 1. Scope

1.1 This test method covers the determination of the comparative thermal conductivity of refractories under standardized conditions of testing. This test method is designed for refractories having a conductivity factor of not more than 200 Btu·in./h·ft<sup>2</sup>·°F (28.8 W/m·K), for a thickness of 1 in. (25 mm).

1.2 Detailed ASTM test methods to be used in conjunction with this procedure in testing specific types of refractory materials are as follows: Test Method C182, Test Method C202, Test Method C417, and Test Method C767.

1.3 The values stated in inch-pound units are to be regarded as standard. The values given in parentheses are mathematical conversions to SI units that are provided for information only and are not considered standard.

1.4 *This standard does not purport to address all of the safety concerns, if any, associated with its use. It is the responsibility of the user of this standard to establish appropriate safety, health, and environmental practices and determine the applicability of regulatory limitations prior to use.*

1.5 *This international standard was developed in accordance with internationally recognized principles on standardization established in the Decision on Principles for the Development of International Standards, Guides and Recommendations issued by the World Trade Organization Technical Barriers to Trade (TBT) Committee.*

### 2. Referenced Documents

2.1 *ASTM Standards:*<sup>2</sup>

C134 Test Methods for Size, Dimensional Measurements, and Bulk Density of Refractory Brick and Insulating Firebrick

<sup>1</sup> This test method is under the jurisdiction of ASTM Committee C08 on Refractories and is the direct responsibility of Subcommittee C08.02 on Thermal Properties.

Current edition approved Jan. 1, 2019. Published January 2019. Originally approved in 1945. Last previous edition approved in 2013 as C201 – 93 (2013). DOI: 10.1520/C0201-93R19E01.

<sup>2</sup> For referenced ASTM standards, visit the ASTM website, www.astm.org, or contact ASTM Customer Service at service@astm.org. For *Annual Book of ASTM Standards* volume information, refer to the standard's Document Summary page on the ASTM website.

C155 Classification of Insulating Firebrick

C182 Test Method for Thermal Conductivity of Insulating Firebrick

C202 Test Method for Thermal Conductivity of Refractory Brick

C417 Test Method for Thermal Conductivity of Unfired Monolithic Refractories

C767 Test Method for Thermal Conductivity of Carbon Refractories

E220 Test Method for Calibration of Thermocouples By Comparison Techniques

### 3. Significance and Use

3.1 The thermal conductivity of refractories is a property required for selecting their thermal transmission characteristics. Users select refractories to provide specified conditions of heat loss and cold face temperature, without exceeding the temperature limitation of the refractory. This test method establishes the testing for thermal conductivity of refractories using the calorimeter.

3.2 This procedure requires a large thermal gradient and steady-state conditions. The results are based upon a mean temperature.

3.3 The data from this test method are suitable for specification acceptance and design of multi-layer refractory construction.

3.4 The use of these data requires consideration of the actual application environment and conditions.

### 4. Apparatus

4.1 The apparatus shall conform in close detail with that shown in the approved drawings.<sup>3</sup> The equipment is shown in Figs. 1 and 2, and the essential parts are as follows:

<sup>3</sup> The complete set of approved drawings necessary for the construction of the apparatus and suggested operating instructions, each of which requires too much space to be included with this test method, was originally drafted by the Insulating Products Division of Babcock and Wilcox Co. ASTM has been advised that these drawings are no longer available. Subcommittee C08.02 is currently taking this issue under advisement.

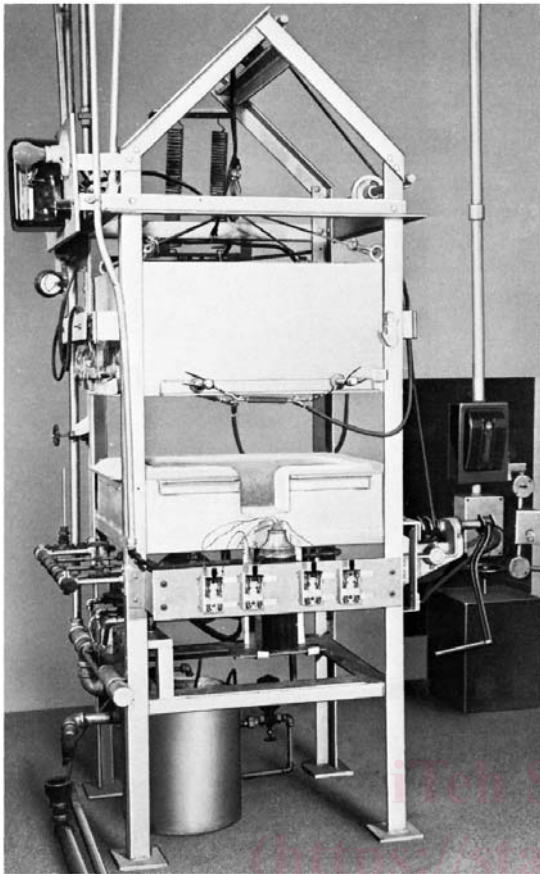

NOTE 1—The upper half of the heating chamber has been raised to permit introduction of the test samples.

FIG. 1 Photograph of Thermal Conductivity Apparatus

4.1.1 *Heating Chamber*—A heating chamber, shown in Fig. 3, shall be capable of being heated electrically over a temperature range from 400 to 2800 °F (205 to 1540 °C) in a neutral or oxidizing atmosphere. The temperature of the heating unit shall be controlled by a mechanism capable of maintaining the temperature in the chamber constant to within  $\pm 5$  °F ( $\pm 3$  °C). A silicon carbide slab 13½ by 9 by 1 in. (342 by 228 by 25 mm), with the 13½ by 9-in. (342 by 228-mm) faces plane and parallel, shall be placed above the sample for the purpose of providing uniform heat distribution. A layer of insulation equivalent at least to 1 in. (25 mm) of Group 20 insulating firebrick (see Classification C155) shall be placed below the calorimeter and guard plates.

4.1.2 *Calorimeter Assembly*—A copper calorimeter assembly, of the design shown in Fig. 4, shall be used for measuring the quantity of heat flowing through the test specimen. The water circulation is such that adjacent passages contain incoming and outgoing streams of water. The calorimeter shall be 3 by 3 in. (76 by 76 mm) square and shall have one inlet and one outlet water connection. The inner guard surrounding the calorimeter shall be 13½ by 9 in. (342 by 228 mm) and shall have two inlet and two outlet water connections. The outer guard shall extend 2 in. (51 mm) laterally from the inner guard and shall extend vertically to the member comprising the bottom of the heating chamber (see

Fig. 3). The separation between the calorimeter and the inner guard shall be ½ in. (0.8 mm).

4.1.3 *Water Circulating System*—A water circulating system shall be provided for supplying the calorimeter assembly with water at constant pressure and at a temperature that is not changing at a rate greater than 1 °F (0.5 °C)/h. The inlet water pressure shall be at least the equivalent of 10 ft of hydrostatic pressure (29.9 kPa). The inlet water temperature shall at all times be within +5 °F (+3 °C) or –2 °F (–1 °C) of the room temperature. Fig. 5 shows the arrangement that shall be used for meeting these conditions. The regulating valves for controlling the rate of water flow through the calorimeter assembly shall be capable of maintaining a constant rate of flow within  $\pm 1$  % during the test period.

4.1.4 *Instruments for Measuring Temperature of Specimen*—Calibrated<sup>4</sup> thermocouples shall be embedded in the test specimen for measuring the temperature. The electromotive force (emf) for the temperature readings shall be taken with a potentiometer having an instrument error of not more than  $\pm 0.05$  mV, and the cold junctions of the thermocouples shall be immersed in a mixture of ice and water.

4.1.5 *Instrument for Measuring Temperature Rise in Calorimeter Water*—A multiple differential thermocouple shall be used for measuring<sup>5</sup> within an accuracy of not less than 1 % of the temperature rise of the water flowing through the calorimeter. The thermocouple shall be immersed at least 3½ in. (89 mm) in the inlet and outlet connections, and the junctions shall be not more than ¼ in. (6 mm) distant from the bottom of the calorimeter. A calibrated differential 10X copper-constantan thermocouple shall be used, and the millivolt readings shall be taken with a potentiometer having an instrument error of not more than  $\pm 0.01$  mV in the range between 0 and 2 mV.

4.1.6 *Instruments for Measuring Temperature Difference Between Calorimeter and Inner Guard*—Calibrated differential 10X copper-constantan thermocouples shall be located in the calorimeter and inner guard for measuring<sup>5</sup> the temperature differences between the calorimeter and inner guard. The temperature difference during a test shall be maintained at a value less than  $\pm 0.05$  °F ( $\pm 0.03$  °C). The thermocouple junctions shall be placed in the four wells provided for that purpose, and millivolt readings shall be taken with a potentiometer having an instrument error of not more than  $\pm 0.01$  mV in the range between 0 and 2 mV.

## 5. Test Sample and Its Preparation

5.1 *Test Sample*—The test sample shall consist of three 9-in. (228-mm) straight brick and six 9 by 2½ by 2¼-in. (228 by 64 by 57-mm) soap brick (Note 2) that are representative of the material being tested. These brick shall be selected for uniformity of structure and bulk density, and they shall be free of broken corners or edges. One brick shall be used as the test

<sup>4</sup> Test Method E220 specifies calibration procedures for thermocouples.

<sup>5</sup> The following procedures are recommended: Roeser, W. F., "Thermoelectric Thermometry," and Roeser, W. F., and Wensel, H. T., "Methods of Testing Thermocouples and Thermocouple Materials," *Temperature, Its Measurement and Control*, Reinhold Publishing Corp., New York, NY, 1941, pp. 180 and 284, respectively.

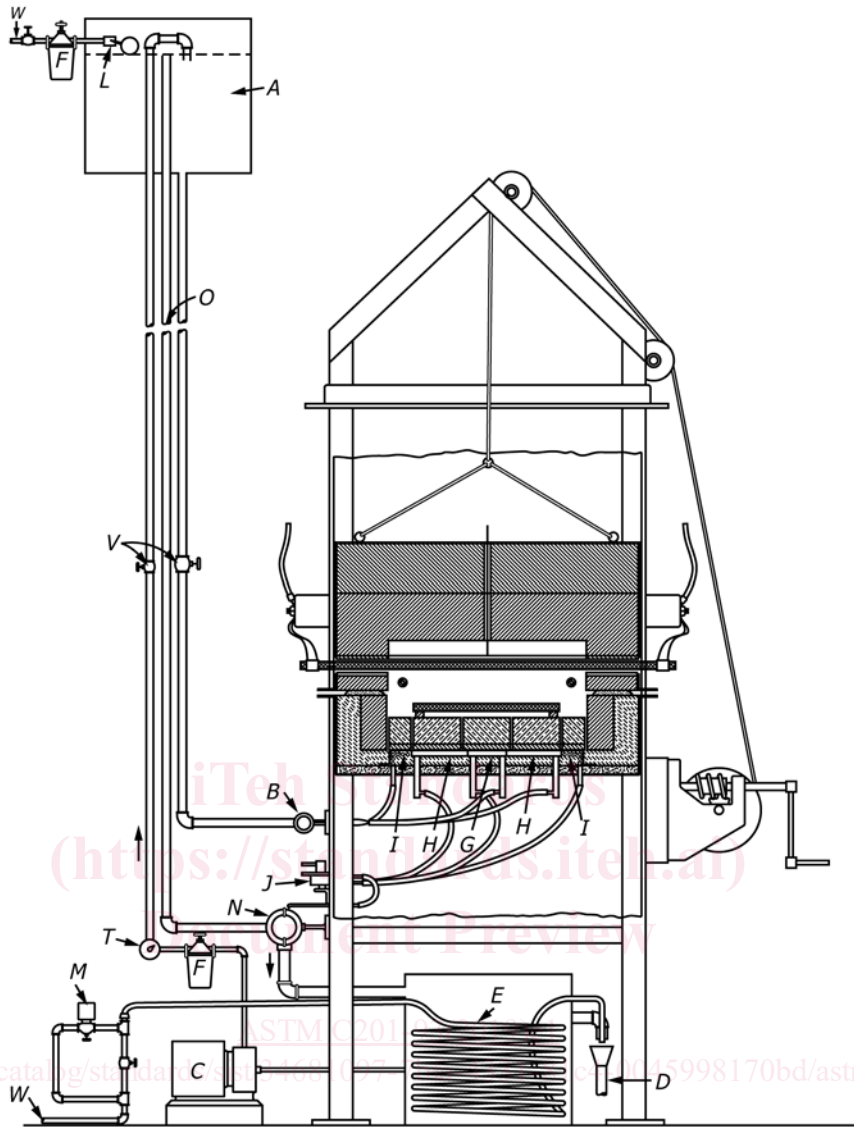

- |                                  |                           |
|----------------------------------|---------------------------|
| A—Constant-head water supply     | J—Microregulating valves  |
| B—Inlet manifold and thermometer | L—Water level valve       |
| C—Circulating pump               | M—Magnetic control valve  |
| D—To drain                       | N—Outlet manifold         |
| E—Cooling coil                   | O—Overflow pipe           |
| F—Water filter                   | T—Thermostat (controls M) |
| G—Center calorimeter             | V—Valves                  |
| H—Inner guard calorimeter        | W—Water inlet             |
| I—Outer guard calorimeter        |                           |

FIG. 2 Diagram Showing Essential Parts of Thermal Conductivity Apparatus

specimen, and one each of the other two brick shall be used as guard brick on either side of the specimen. The six soap brick shall be placed around the edges of the test specimen and guard brick to prevent side flow of heat. The test specimen and guard brick shall cover an area of approximately 18 by 13½ in. (456 by 342 mm).

NOTE 1—A total of nine 9-in. (228-mm) straight brick may be submitted for test, six of which would be cut to obtain the soap brick.

5.2 Preparation of Test Sample—The 9 by 4½-in. (228 by 114-mm) faces of the three straight brick and the 9 by 2¼-in.

(228 by 57-mm) faces of the soap brick shall be ground flat and parallel, and the thickness shall not vary more than ±0.01 in. (±0.3 mm). The thickness shall be not more than 3 (76 mm) nor less than 2 in. (51 mm). The sides that are to be placed in contact shall be ground flat and at right angles to the 9 by 4½-in. face of the brick and the 9 by 2¼-in. face of the soap brick.

NOTE 2—Additional instructions are given in the methods of test for specific materials (see Section 7) concerning the preparation of the specimen, placing of guard brick, and the like.