



Designation: C627 – 18^{ε1}

Standard Test Method for Evaluating Ceramic Floor Tile Installation Systems Using the Robinson-Type Floor Tester¹

This standard is issued under the fixed designation C627; the number immediately following the designation indicates the year of original adoption or, in the case of revision, the year of last revision. A number in parentheses indicates the year of last reapproval. A superscript epsilon (ϵ) indicates an editorial change since the last revision or reapproval.

^{ε1} NOTE—Editorially updated adjunct stock codes in November 2022.

1. Scope

1.1 This test method covers the evaluation of ceramic floor tile installation systems, using the Robinson²-type floor tester.

1.2 This test method is intended solely for evaluating complete ceramic floor tile installation systems for failure under dynamic loads and not for evaluating particular characteristics of ceramic tile, such as abrasion resistance. This test method does not claim to provide meaningful results for other than evaluating complete ceramic floor tile installation systems.

1.3 The values stated in inch-pound units are to be regarded as the standard. The metric (SI) units in parentheses are for information only.

1.4 *This standard does not purport to address all of the safety concerns, if any, associated with its use. It is the responsibility of the user of this standard to establish appropriate safety, health, and environmental practices and determine the applicability of regulatory limitations prior to use.*

1.5 *This international standard was developed in accordance with internationally recognized principles on standardization established in the Decision on Principles for the Development of International Standards, Guides and Recommendations issued by the World Trade Organization Technical Barriers to Trade (TBT) Committee.*

2. Referenced Documents

2.1 *ASTM Standards:*³

C144 Specification for Aggregate for Masonry Mortar

C150 Specification for Portland Cement

2.2 *ASTM Adjuncts:*

Robinson-type Floor Tester²
Deflection Gauge⁴

3. Summary of Test Method

3.1 This test method consists of preparing test assemblies that duplicate the type of installation under consideration, subjecting them to one or more tests on the Robinson floor tester, and evaluating the results in a prescribed manner. Description of the installation method must specifically include all variables, for example, the type of materials and mixture proportions of substratum, setting material, and tile grout; type of tile, installation technique, and cure.

4. Significance and Use

4.1 This test method provides a standardized procedure for evaluating performance of ceramic floor tile installations under conditions similar to actual specific usages. It can be used to make comparisons between customary basic installation methods, to establish the influence of minor changes in a particular installation method, and to judge the merit of proposed novel methods.

5. Apparatus

5.1 *Foundation for Tester*—The foundation for the tester shall consist of a minimum 4 by 4-ft (1220 by 1220-mm) square and 1-ft (300-mm) thick cement slab. The testing surface of this slab shall be smooth, level, and flat with the maximum deviation from a true plane not to exceed $\frac{1}{32}$ in. (0.8 mm). The foundation may be equipped for a bottom or top driven tester. Please see X1.1 for construction details for a foundation using a bottom driven tester that has been known to meet the requirements of the test method.

⁴ Detailed working drawings for construction of a deflection gauge known to meet the requirements of this standard are available at nominal cost from ASTM Headquarters. Order Adjunct No. [ADJC062702](#) or [ADJC062702-E-PDF](#) (digital version).

¹ This test method is under the jurisdiction of ASTM Committee C21 on Ceramic Whitewares and Related Products and is the direct responsibility of Subcommittee C21.06 on Ceramic Tile.

Current edition approved March 1, 2018. Published April 2018. Originally approved in 1970. Last previous edition approved in 2010 as C627 – 10^{ε1}. DOI: 10.1520/C0627-18E01.

² Detailed working drawings of the apparatus known to meet the requirements of this standard are available at a nominal cost from ASTM Headquarters. Order Adjunct No. [ADJC062701](#) or [ADJC062701-E-PDF](#) (digital version).

³ For referenced ASTM standards, visit the ASTM website, [www.astm.org](#), or contact ASTM Customer Service at [service@astm.org](#). For *Annual Book of ASTM Standards* volume information, refer to the standard's Document Summary page on the ASTM website.

5.2 *Tester*—The tester itself shall be a 150 ± 5-lbs (68.1 ± 2.3-kg) carriage in the shape of an equilateral triangle. Three swivel caster wheels shall be equally spaced in a circle with 15-in. (381-mm) radius from the center and fastened to the underside of the carriage at the intersection of the bisector of each angle and the 15-in. (381-mm) radius circle. The carriage shall be capable of supporting 750 lbs (340.5 kg) of additional weight, 250 lbs (113.5 kg) of auxiliary weights over each wheel. The auxiliary weight stacks shall be sufficiently secured to the carriage. Cutaway diagrams of a bottom-driven apparatus and of a top-driven apparatus are shown in Fig. 1. Please see X1.2 for construction details² for one example of a tester known to meet the requirements of the test method.

5.3 *Drive*—The tester shall be driven by a motor and speed reducer, variable speed drive, or equivalent, capable of rotating the carriage at 15 ± 0.5 rpm during testing. Drive transmittal shall be arranged in such a manner that the plane of travel and the elevation of the carriage are free to accommodate various types of test assemblies. The drive shaft (whether top or bottom driven tester) shall be equipped with a universal joint between the driveshaft and carriage to allow contact between the wheels and test panel at all times.

5.4 *Revolution Counter or Timer*—A revolution counter, capable of recording up to 1000 revolutions, or an automatic timing device which can be present to stop the tester.

5.5 *Wheels*—The wheels shall be attached to swivel casters with removable axles, equipped with grease fittings. All casters shall be of ball bearing construction. The wheels shall be 4 ±

1/8 in. (102 ± 3 mm) in diameter and 1 3/8 ± 1/16-in. (35 ± 1.6 mm) in width. The wheels shall be equipped with roller or ball bearings. Three sets of three wheels each are required, namely:

5.5.1 One set of soft rubber wheels with a 78 ± 3 Shore A durometer hardness⁵,

5.5.2 One set of hard rubber wheels with a 80 ± 3 Shore D durometer hardness⁵, and

5.5.3 One set of steel wheels with a steel surface. The surface of the steel wheel shall be curved in such a way that the radius in the center is greater than the radius on the edge by approximately 3/128 in. (0.6 mm). See Fig. 2.

5.6 *Weights*—750-lbs (340 kg) of auxiliary weights are required. Weights may be of any size or shape so long as they meet the requirements found in 5.2 and the loading schedule found in Table 1. Thirty 25-lb (11.5-kg) disk-shaped, 11-in. (280-mm) diameter bar bell weights have been known to work. Accuracy of the weights shall be ± 2 %.

5.7 *Deflection Gauge (optional)*—A gauge accurate to 0.001 in. (0.025 mm) which may be inserted between the upper and lower sheet of a plywood base to measure the deflection of the base under the path of the wheels.

⁵ The wheels must be conditioned at 73.4 ± 3.6°F (23 ± 2°C) for a minimum of 24 hours prior to measuring the durometer hardness. Shore A and Shore D durometer hardness measurements shall be taken in the center of the wheel width prior to the wheel being placed into service on each test panel.

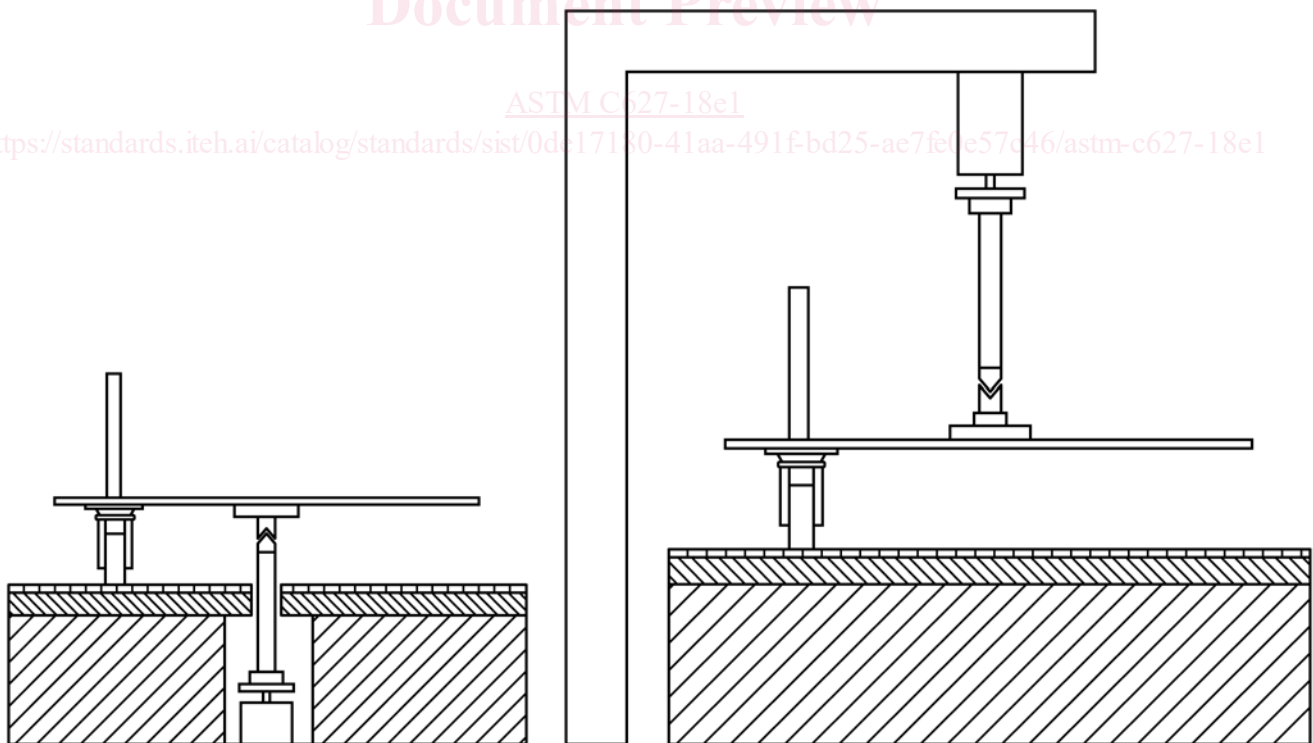

FIG. 1 Bottom- and Top-Driven Floor Tile Installations Systems Testers (Not to Scale)

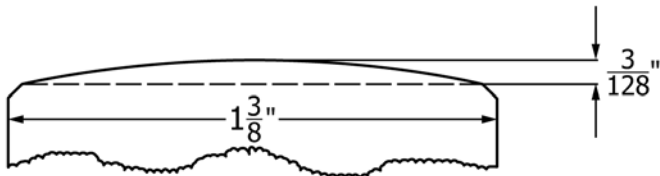

FIG. 2 Steel Wheel Surface Profile

6. Test Panel Assemblies

6.1 The base upon which the tile are installed, the bonding medium, the type of tile mountings, the type of grout, and the type of tile used may be varied with the requirements of the test.

6.1.1 *Mortar Base for Portland Cement Installations*—A recommended mortar base panel for portland cement installations may be cast without reinforcements into a 2-in. (51-mm) thick square with minimum dimensions of 4- by 4-ft (1220- by 1220-mm), from a mortar mix consisting of six parts by weight of dry sand, clean and graded (see Specification C144) and one part by weight of portland cement (Type I of Specification C150), with enough potable water to make a relatively dry mortar which, when stroked with a trowel, gives a smooth, slick appearance. Up to four one half-inch (12.7-mm) diameter, 11-in. (280-mm) long sections of pipe or metal rod, projecting about 5 in. (127 mm), may be horizontally cast into alternate sides of the panel to serve as lifting handles. An opening up to 6-in. (152-mm) square may be cast or cut in the center of the mortar base panel to permit entry of the drive shaft for bottom driven testers. For conventional-type installation methods, the tile shall be set before the mortar hardens. After curing in accordance with the recommendation of the manufacturer or supplier of the product(s) being tested, such a panel is set in place on the foundation of the testing machine with an easily removable plaster. A polyethylene sheet shall be laid between the foundation of the tester and the plaster, so that the mortar-base test panel can be easily removed after completion of the test. A plaster mix of ten parts by weight of dry sand, clean and graded (Specification C144) and one part by weight of gypsum plaster with enough water to make a fairly thick slurry has been found satisfactory. Construction details for such a panel are shown in Fig. 3.

6.1.2 *Concrete Base for Thin-Bed Installations*—The size and construction of such a concrete base shall be the same as that described under 6.1.1, except that the concrete mix shall consist of three parts of gravel not over 3/4 in. (19 mm) in size, two and one-half parts of dry sand, clean and graded (Specification C144), one part of portland cement (Type I of Specification C150) and one part of potable water, all parts by weight. Unless otherwise specified, the concrete base panel shall be cured for at least seven days before the installation of tile. The concrete base is set in place on the foundation of the tester with plaster as described in 6.1.1.

6.1.3 *Plywood Base for Installations*—The plywood base shall be of sandwich construction. For maximum stiffness, the plywood face grain direction should be installed so as to run perpendicular to the floor joist or supports. The top shall consist of two sections of plywood of thickness specified by the manufacturer or supplier of the product(s) being tested such

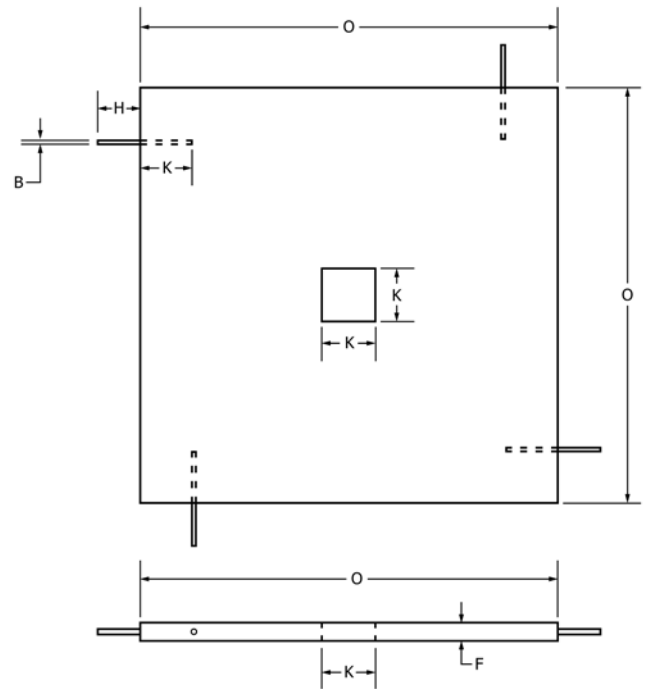

FIG. 3 Concrete Base Panel (Not to Scale)

Dimension Table		
Key	in.	mm
B (optional)	1/2	12.7
F	2	50.8
H (optional)	5	127.0
K (optional)	6	152.4
O	48	1219

that the joint between the two sections runs perpendicular to the joists and tangential to the center of the wheel path. runs perpendicular to the joists and tangential to the center of the wheel path. The joint between the two sections of plywood shall be finished per the recommendation of the manufacturer or supplier of the product(s) being tested. The bottom shall be a minimum 1/4-in. (6.4-mm) plywood. In between the top and bottom of the panel on 16-in. (406-mm) centers, shall be four 4-ft (1220-mm) long sections of wood which are nominally 2 in. (50 mm) wide (2 by 2 in. [50 by 50 mm] or 2 by 4 in. [50 by 100 mm] lumber) to duplicate the support rendered by joists in an actual installation. An opening up to 6-in. (152-mm) square may be cut in the center of the panel to permit entry of the drive shaft for bottom driven testers. For details of construction of such a panel see Fig. 4. The panel should be reasonably secured to not allow movement of the panel during testing.

6.1.3.1 *Plywood Base with Panel-Type or Sheet-Type Underlayment*—If a panel-type underlayment (for example, backerboard) or a sheet-type underlayment (for example, sheet membrane) is to be installed atop the plywood base, it shall consist of two sections such that the joint between the two sections runs parallel to the joists and tangential to the center of the wheel path. The installation of the two sections of underlayment atop the plywood base and the preparation of the joint between the two sections of underlayment shall be