



Designation: A1111 – 22

Standard Specification for Cast Iron Closet Flanges for Use with Cast Iron Soil Pipe and Fittings in Gravity Flow Plumbing Drain, Waste, and Vent Sanitary Applications¹

This standard is issued under the fixed designation A1111; the number immediately following the designation indicates the year of original adoption or, in the case of revision, the year of last revision. A number in parentheses indicates the year of last reapproval. A superscript epsilon (ϵ) indicates an editorial change since the last revision or reapproval.

1. Scope

1.1 This specification covers cast iron soil closet flanges for use in gravity flow plumbing drain, waste, and vent sanitary applications. It establishes standards covering material, manufacture, mechanical and chemical properties, coating, test methods, inspection, certification, product markings, dimensions, and dimensional tolerances for closet flanges. These closet flanges are not intended for pressure applications, as the selection of the proper size for sanitary drain, waste, vent, and storm drain systems allows free air space for gravity drainage

1.2 The EDP/ASA numbers indicated in this section represent a Uniform Industry Code adopted by the American Supply Association (ASA). A group designation prefix, 022, is assigned to hubless products followed by the four-digit identification assigned to individual items and a check digit. This system has been instituted to facilitate EDP control through distribution channels, and is to be used universally in ordering and specifying product items. Those items with no EDP numbers are either new, special, or transitory and will be assigned numbers on subsequent prints of this specification.

1.3 This specification covers closet flanges of the following patterns (7.1.1) and, when so designated, shall apply to any other patterns that conform with the applicable requirements given in this specification.

1.4 The values stated in inch-pound units are to be regarded as standard. The values given in parentheses are mathematical conversions to SI units that are provided for information only and are not considered standard.

1.5 *This international standard was developed in accordance with internationally recognized principles on standardization established in the Decision on Principles for the Development of International Standards, Guides and Recom-*

mendations issued by the World Trade Organization Technical Barriers to Trade (TBT) Committee.

2. Referenced Documents

2.1 ASTM Standards:²

- A48/A48M Specification for Gray Iron Castings
 - A74 Specification for Cast Iron Soil Pipe and Fittings
 - A644 Terminology Relating to Iron Castings
 - A888 Specification for Hubless Cast Iron Soil Pipe and Fittings for Sanitary and Storm Drain, Waste, and Vent Piping Applications
 - C564 Specification for Rubber Gaskets for Cast Iron Soil Pipe and Fittings
 - D3960 Practice for Determining Volatile Organic Compound (VOC) Content of Paints and Related Coatings
 - E8/E8M Test Methods for Tension Testing of Metallic Materials
 - E1645 Practice for Preparation of Dried Paint Samples by Hotplate or Microwave Digestion for Subsequent Lead Analysis
 - E2349 Practice for Safety Requirements in Metal Casting Operations: Sand Preparation, Molding, and Core Making; Melting and Pouring; and Cleaning and Finishing
- ### 2.2 Federal Standard:³
- Fed. Std. No. 123 Marking for Shipment (Civil Agencies)
- ### 2.3 Military Standard:⁴
- MIL-STD-129 Marking for Shipment and Storage

3. Terminology

3.1 Definitions of Terms Specific to This Standard:

3.1.1 *closet flange, n*—a flange used to connect a water closet to the sanitary piping in drain, waste, and vent applications.

² For referenced ASTM standards, visit the ASTM website, www.astm.org, or contact ASTM Customer Service at service@astm.org. For *Annual Book of ASTM Standards* volume information, refer to the standard's Document Summary page on the ASTM website.

³ Available from General Services Administration – Vendor Support Center, <https://vsc.gsa.gov/administration/files/FEDSTD123H.pdf>.

⁴ Available from General Services Administration – Vendor Support Center, <https://vsc.gsa.gov/administration/files/MIL-STD-129R.pdf>.

¹ This specification is under the jurisdiction of ASTM Committee A04 on Iron Castings and is the direct responsibility of Subcommittee A04.12 on Pipes and Tubes.

Current edition approved Nov. 1, 2022. Published November 2022. Originally approved in 2018. Last previous edition approved in 2018 as A1111 – 18. DOI: 10.1520/A1111-22.

3.1.2 *manufacturer, n*—the entity that casts the closet flanges covered by this standard.

4. Materials and Manufacture

4.1 The closet flanges shall be iron castings suitable for installation and service for sanitary drain, waste, and vent piping applications. The closet flanges shall meet all applicable requirements and tests given in this specification.

4.2 The castings shall be made of cast iron produced by an established commercial method that provides control over chemical and physical properties. Cast iron is a generic term for a series of alloys as defined in Terminology **A644**, and includes gray iron as well as ductile iron. The castings shall be sound, true to pattern, and of compact close grain that permits drilling and cutting by ordinary methods. The interior surface shall be reasonably smooth and free from defects that would make the castings unfit for the use for which they are intended.

4.3 To minimize the possibility of introducing radioactive material to a melting operation, ferrous scrap, pig iron, and any recycled ferrous material shall be screened by the manufacturer for radioactivity with detection devices operated in accordance with the detection manufacturer's instructions. Written operating, calibration, and maintenance procedures for the detection equipment shall be provided to the purchaser for review when requested. Records shall be maintained by load of these tests for a period of seven years.

4.3.1 Only radiation devices designed specifically for the purpose of screening ferrous material shipments shall be used for the purpose of conforming to this requirement. Handheld radiation detectors (Geiger counters) are not appropriate and shall not be used for the purpose of conforming to this requirement.

4.3.2 Material that is found contaminated with radioactivity shall not be used to produce products covered by this specification.

4.3.3 Analysis of castings after the time of production shall not be used to determine compliance to this specification.

4.4 Foundries manufacturing products to this specification shall comply to all local, provincial, state, and national safety laws and regulations and to the requirements of Practice **E2349**.

4.5 Closet flanges shall not be patched, filled, or welded to correct cosmetic or material defects that occur during the course of manufacturing.

5. Mechanical Properties

5.1 *Mechanical Tests for Gray Iron*—The manufacturer shall perform tests to determine mechanical properties of the gray iron used in the manufacture of gray iron soil pipe and fittings. Tension test specimens shall be employed, in accordance with details in **10.1.1**. The manufacturer shall maintain a record of mechanical tests for a minimum of seven years.

5.1.1 *Tensile Strength Test*—The tensile strength shall be not less than 21 000 psi (145 MPa).

5.1.2 Tension test reports shall include breaking load of test bars, machined diameter of test bar, and calculated tensile strength.

5.1.3 Analysis of castings or test bars after the time of production shall not be used as evidence of compliance to this specification.

6. Chemical Tests for Gray Iron

6.1 The manufacturer shall perform tests to determine the significant chemical constituents of the gray iron used in the manufacture of gray iron soil pipe and fittings and closet flanges. Analysis shall be performed at the minimum of once per lot as defined in this specification. The manufacturer shall maintain a record of chemical tests performed for a minimum of seven years. The test results shall conform to the following requirements as to chemical composition:

| | |
|-------------------|------------------------|
| Phosphorous (P) | 0.38 % maximum |
| Sulfur (S) | 0.15 % maximum |
| Chromium (Cr) | 0.50 % maximum |
| Titanium (Ti) | 0.10 % maximum |
| Aluminum (Al) | 0.50 % maximum |
| Lead (Pb) | 0.015 % maximum |
| Carbon Equivalent | 4.10 % minimum by mass |

Note: Carbon equivalent for gray iron = %C+%Si/3+%P/3

6.1.1 Chemical tests shall be performed at the time of production of the castings covered by this specification.

6.1.2 Analysis of castings after the time of production shall not be used as evidence of compliance to this specification.

7. Dimensions and Permissible Variations

7.1 Closet Flanges:

7.1.1 *Dimensions of Closet Flanges*—All closet flanges shall conform to the dimensions specified in **Fig. 1**.

7.2 *Hubless Closet Flange Riser*—For information on hubless closet flange risers, refer to **Fig. 57** of Specification **A888**.

8. Coating

8.1 The closet flanges shall be uniformly coated with a material suitable for the purpose that is adherent and not brittle. The coating shall be applied in accordance with the coating manufacturer's requirements. External touch marks from points of contact during the coating process are permitted. The coating shall not contain asbestos above current MSDS reportable levels. Safety Data Sheets shall be furnished by the coating manufacturer when requested. The coating shall be evenly and smoothly applied to all surfaces, except in threaded openings, unless the coating is specifically designed for threaded openings.

8.2 Closet flange coatings shall not contain lead which exceeds levels above 0.06 % (600 ppm).

8.2.1 The manufacturer shall annually prepare and submit samples to a qualified laboratory for test in accordance with Practice **E1645**. The manufacturer shall prepare and submit samples when changing sources of supply or the coating manufacturer changes formulations for the coating.

8.3 Closet flange coatings shall not contain levels of volatile organic hazardous air pollutants (VOHAPs) which exceed levels of 2.6 lb of VOHAPs per gallon (0.31 kg per liter) of solids in accordance with Practice **D3960**.

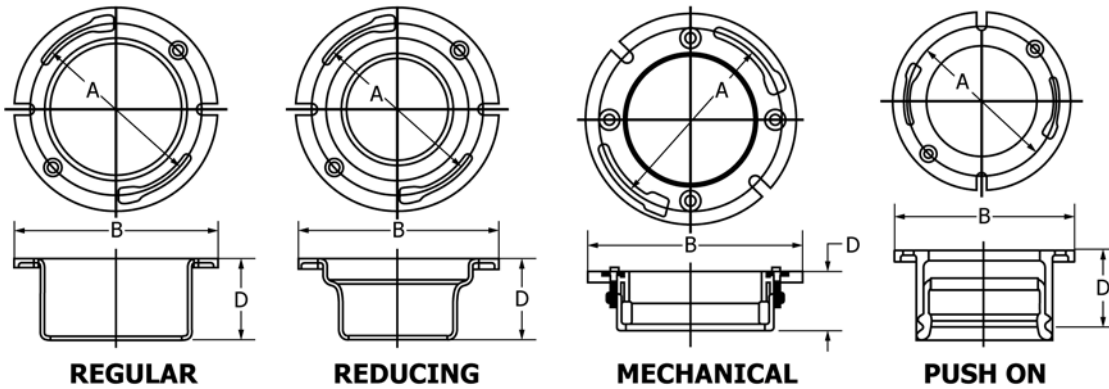

| ASA Code Group 022 | | Item | Size, inches | Dimensions, inches | | | |
|-----------------------|---|------------|-----------------|--------------------|----|----|------------|
| Item No. | ✓ | | | A | B | D | I.D. (min) |
| 2971 | 8 | Regular | 4 | 6¼ | 7¼ | 1 | 4½ |
| 2972 | 0 | Regular | 4 | 6¼ | 7¼ | 1½ | 4½ |
| 2973 | 6 | Regular | 4 | 6¼ | 7¼ | 2 | 4½ |
| 2974 | 4 | Regular | 4 | 6¼ | 7¼ | 2½ | 4½ |
| 2975 | 2 | Regular | 4 | 6¼ | 7¼ | 3 | 4½ |
| 2976 | 4 | Regular | 4 | 6¼ | 7¼ | 4 | 4½ |
| 2977 | 0 | Regular | 4 | 6¼ | 7¼ | 5 | 4½ |
| 2978 | 6 | Regular | 4 | 6¼ | 7¼ | 6 | 4½ |
| 2979 | 8 | Reducing | 4 × 3 | 6¼ | 7¼ | 3 | 3½ |
| 2980 | 4 | Mechanical | 4 × 2 | 6¼ | 7⅞ | 2 | 4½ |
| 2983 | 0 | Mechanical | 4 × 3 | 6¼ | 7⅞ | 2 | 4½ |
| 2984 | 0 | Push-on | 4 × 3 | 6¼ | 7⅞ | 3⅝ | 3½ |
| | | Mechanical | 4 × 4 | 6¼ | 7⅞ | 4 | 4½ |
| | | Threaded | 4 × 3 | 6¼ | 7⅞ | 3 | 3½ |

NOTE 1—Tolerance $\pm 1/8$ in.

NOTE 2—Flange and barrel thickness shall be a minimum of 0.13 in.

NOTE 3—Gasket materials for mechanical closet flanges shall meet the requirements of Specification C564.

NOTE 4—Bolts for mechanical closet flanges shall be series 300 stainless steel.

NOTE 5—Flanges shall be permitted to be slotted, notched, or a combination of slotted and notched.

FIG. 1 Closet Flanges

8.3.1 The manufacturer shall annually certify that the coating meets the VOHAP requirement. It is permissible for the coating manufacturer to provide the certification.

8.4 Records shall be maintained for a period of seven years.

8.5 Copies of the coating test shall be furnished when requested.

9. Sampling

9.1 Chemical and mechanical tests shall be made regularly and at sufficiently close intervals for adequate determinations of the significant chemical constituents and properties of the cast iron. A specimen taken from a finished product often does not produce the same results as a specimen formed by the method used for sample preparation and is not acceptable for the purpose of testing to this standard. Records of chemical analysis shall be maintained by the manufacturer by lot. Copies of these analyses shall be furnished to the purchaser when requested.

9.2 A lot shall consist of all the metal poured for a given period of time between changes in charge, processing conditions, aim-for chemistry, or 4 h, whichever is the shorter period.

10. Test Methods

10.1 Gray Iron:

10.1.1 *Tensile Strength Test*—Test bars shall be cast in accordance with the requirements of Specification A48/A48M. See Fig. 2 for the machined test bar dimensions and as-cast test bar dimensions. The tensile strength shall be determined in accordance with Test Methods E8/E8M.

10.1.2 Tension test reports shall include breaking load of test bars, machined diameter of test bar, and calculated tensile strength.

11. Inspection

11.1 *Inspection and Test by the Manufacturer*—Closet flanges shall be inspected to verify compliance with this specification. The manufacturer shall maintain a record of all inspections.

11.2 *Closet Flange Inspection*—At regular intervals (not to exceed 12 h) during the course of production, sample pieces of each size and configuration of closet flange being produced shall be selected randomly for inspection. Each closet flange selected shall be measured by suitable gauges to verify that the length and all applicable dimensions detailed in Fig. 1 comply

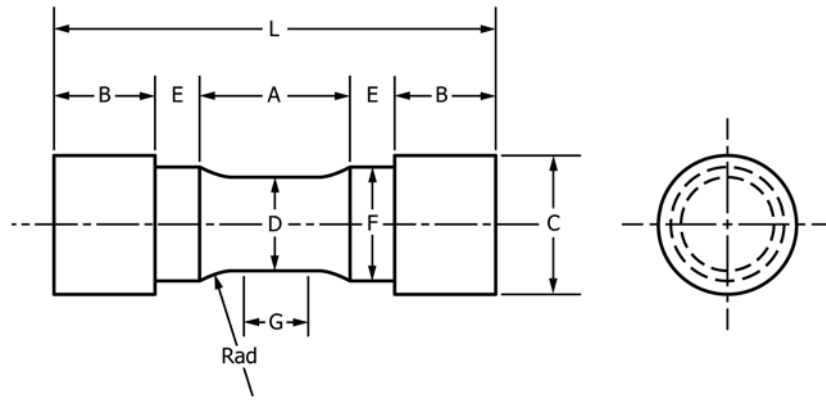

| Dimensions, in. (mm) | | | Tension Test Specimen B | |
|----------------------|---------------------------------|--|-----------------------------|--|
| G | Length of parallel, min | | 0.75 (19) | |
| D | Diameter | | 0.750 ± 0.015 (19.0 ± 0.38) | |
| R | Radius of fillet, min | | 1 (25) | |
| A | Length of reduced section, min | | 1½ (38) | |
| L | Overall length, min | | 4 (100) | |
| C | Diameter of end section, approx | | 1¼ (32) | |
| E | Length of shoulder, min | | ¼ (6) | |
| F | Diameter of shoulder | | 15/16 ± 1/64 (25 ± 0.4) | |
| B | Length of end section | | A | |

| Test Bar | As-Cast Diameter, in. (mm) | | | Length, in. (mm) | |
|----------|----------------------------|------------------|---------------|---------------------|-----------------------|
| | Nominal (Mid-Length) | Minimum (Bottom) | Maximum (Top) | Minimum (Specified) | Maximum (Recommended) |
| B | 1.20 (30.5) | 1.14 (29.0) | 1.32 (33.5) | 6.0 (150) | 9.0 (230) |

^A Optional to fit holders on testing machine. If threaded, root diameter shall not be less than dimension F.

FIG. 2 Tension Test Specimens

with the requirements of this specification. The inspection records shall be maintained by the manufacturer for a period of seven years.

11.3 *Marking Inspection*—Inspection shall include verification that the markings on pipe and fittings comply with Section 13 of this specification.

12. Certification

12.1 Upon request, the purchaser, design professional, or the administrative authority having jurisdiction where the products are being installed shall be furnished certification by the manufacturer stating samples representing each lot have been tested and inspected as indicated in this specification and the requirements have been met. If requested by the purchaser, design professional, or the administrative authority having jurisdiction where the products are being installed, certification shall be accompanied by test reports as prepared in accordance with Sections 10 and 11 of this specification. Tension test reports shall include breaking load, machined diameters of test bars, and calculated tensile strength. Certification shall include the legal name and address of the manufacturer.

12.2 Third-party certifiers or inspectors shall utilize the procedures detailed in Annex A1 when conducting inspections at the manufacturing locations.

13. Product Marking

13.1 Each closet flange shall be plainly marked with the country of origin, the manufacturer’s name, or registered

trademark by which the manufacturer can be readily identified after installation. The markings shall be adequate identification of the manufacturer of the closet flange if it readily identifies the manufacturer to the end user of the product. Other markings on closet flanges are permitted as long as such markings are not misleading with respect to the identification of the manufacturer by the end user.

13.2 The marking shall be cast with raised or indented letters on closet flanges, and shall be clear and legible after installation and located away from the spigot end so as not to interfere with proper joining upon installation. Markings shall be visible prior to installation or setting of the fixture.

14. Packaging and Package Marking

14.1 *Government Procurement*—Unless otherwise specified in the contract, the material shall be packaged in accordance with the supplier’s standard practice that will be acceptable to the carrier at lowest rates. Containers and packing shall comply with Uniform Freight Classification Rules⁵ or National Motor Freight Classification Rules.⁶ Marking for shipment of such material shall be in accordance with Fed. Std. No. 123 for civil agencies and MIL-STD-129 for military agencies.

⁵ Available from The Uniform Classification Commission, Room 1106, 222 S. Riverside Plaza, Chicago, IL 60606.

⁶ Available from National Motor Freight Traffic Association, Inc. (NMFTA), 1001 N. Fairfax St., Suite 600, Alexandria, VA 22314-1798, http://www.nmfta.org.