



Designation: A1109 – 22

# Standard Specification for Special Fittings for Single-Stack Hubless Cast Iron Soil Pipe Fittings for Sanitary, Waste, and Vent Piping Applications<sup>1</sup>

This standard is issued under the fixed designation A1109; the number immediately following the designation indicates the year of original adoption or, in the case of revision, the year of last revision. A number in parentheses indicates the year of last reapproval. A superscript epsilon ( $\epsilon$ ) indicates an editorial change since the last revision or reapproval.

## 1. Scope

1.1 This specification covers special hubless cast iron soil pipe fittings for use in a one-pipe combination vent and waste stack unvented for gravity flow applications. It establishes standards covering material, manufacture, mechanical and chemical properties, dimensions, coating, test methods, inspection, certification, and product marking for hubless cast iron soil pipe fittings. These fittings are intended for nonpressure applications, where the selection of the proper size for sanitary, drain, and waste systems allows free air space for gravity drainage.

NOTE 1—The fittings covered by this standard are special fittings intended to be used for engineered designed systems and will require special approval by the authority having jurisdiction for use. It is not the intent of this standard to endorse or recommend the use of these fittings for these special applications.

1.2 The EDP/ASA numbers indicated in this section represent a uniform industry code adopted by the American Supply Association (ASA). A group designation prefix, 022, is assigned to hubless products, followed by the four-digit identification assigned to individual items and a check digit. This system has been instituted to facilitate EDP control through distribution channels, and is to be used universally in ordering and specifying product items. Those items with no EDP numbers are new, special, or transitory, and will be assigned numbers on subsequent prints of this specification.

1.3 This specification covers fittings of the following patterns and applies to any other patterns that conform with the applicable requirements given in this specification.

NOTE 2—The text of this standard references notes and footnotes that provide explanatory material. These notes and footnotes (excluding those in tables and figures) shall not be considered as requirements of the standard.

NOTE 3—Some sellers of these fittings use the terms “aerator” and “de-aerator” fittings to describe the two types of fittings covered by this standard.

<sup>1</sup> This specification is under the jurisdiction of ASTM Committee A04 on Iron Castings and is the direct responsibility of Subcommittee A04.12 on Pipes and Tubes.

Current edition approved Nov. 1, 2022. Published November 2022. Originally approved in 2018. Last previous edition approved in 2018 as A1109 – 18. DOI: 10.1520/A1109-22.

1.4 *This international standard was developed in accordance with internationally recognized principles on standardization established in the Decision on Principles for the Development of International Standards, Guides and Recommendations issued by the World Trade Organization Technical Barriers to Trade (TBT) Committee.*

## 2. Referenced Documents

### 2.1 ASTM Standards:<sup>2</sup>

A48/A48M Specification for Gray Iron Castings

A644 Terminology Relating to Iron Castings

D3960 Practice for Determining Volatile Organic Compound (VOC) Content of Paints and Related Coatings

E8/E8M Test Methods for Tension Testing of Metallic Materials

E1645 Practice for Preparation of Dried Paint Samples by Hotplate or Microwave Digestion for Subsequent Lead Analysis

### 2.2 U.S. Federal Standard:<sup>3</sup>

Federal Standard No. 123 Marking for Shipment (Civil Agencies)

### 2.3 Military Standard:<sup>3</sup>

MIL-STD-129 Marking for Shipment and Storage

### 2.4 Other Documents:

Uniform Freight Classification Rules<sup>4</sup>

National Motor Freight Classification Rules<sup>5</sup>

## 3. Terminology

### 3.1 Definitions of Terms Specific to This Standard:

3.1.1 *manufacturer*—the entity that casts the fittings covered by this standard.

<sup>2</sup> For referenced ASTM standards, visit the ASTM website, [www.astm.org](http://www.astm.org), or contact ASTM Customer Service at [service@astm.org](mailto:service@astm.org). For *Annual Book of ASTM Standards* volume information, refer to the standard's Document Summary page on the ASTM website.

<sup>3</sup> Available from DLA Document Services, Building 4/D, 700 Robbins Ave., Philadelphia, PA 19111-5094, <http://quicksearch.dla.mil>.

<sup>4</sup> Available from Uniform Classification Commission, Room 1106, 222 S. Riverside Plaza, Chicago, IL 60606.

<sup>5</sup> Available from National Motor Freight Traffic Association, Inc. (NMFTA), 1001 N. Fairfax St., Suite 600, Alexandria, VA 22314-1798, <http://www.nmfta.org>.

## 4. Materials and Manufacture

4.1 The fittings shall be iron castings suitable for installation and service for sanitary, storm drain, and waste vent piping applications. The fittings shall meet all applicable requirements and tests given in this specification.

4.2 The castings shall be made of cast iron, produced by an established commercial method that provides control over chemical and mechanical properties. “Cast iron” is a generic term for a series of alloys as defined in Terminology **A644** and includes gray iron as well as ductile iron. The castings shall be sound, true to pattern, and of compact close grain that permits drilling and cutting by ordinary methods. The interior surface shall be reasonably smooth and free from defects that would make the castings unfit for the use for which they are intended.

4.3 To minimize the possibility of introducing radioactive material to a melting operation, ferrous scrap, pig iron, and any recycled ferrous material shall be screened by the manufacturer for radioactivity with suitable detection devices operated in accordance with the detection manufacturer’s instructions. Written operating, calibration, and maintenance procedures for the detection equipment shall be provided to the purchaser for review when requested. Records shall be maintained by load of these tests for a period of seven years.

4.3.1 Only radiation detection devices designed specifically for the purpose of screening ferrous material shipments shall be used for the purpose of conforming to this requirement. Handheld detection devices (Geiger counters) are not appropriate and shall not be used for the purpose of conforming to this requirement.

4.3.2 Material that is found contaminated with radioactivity shall not be used to produce products covered by this specification.

4.3.3 Analysis of castings after the time of production shall not be used to determine compliance to this specification.

4.4 Fittings shall not be patched, filled, or welded by the manufacturer to repair cosmetic or material defects that occur during the course of manufacturing.

## 5. Mechanical Properties

5.1 *Mechanical Tests for Gray Iron*—The manufacturer shall perform tests to determine mechanical properties of the gray iron used in the manufacture of gray iron soil pipe fittings. Tension tests on the specimens shall be employed. The manufacturer shall maintain a record of mechanical tests for a minimum of seven years.

5.1.1 *Tensile Strength Test*—The tensile strength shall be not less than 21 000 psi (145 MPa).

5.1.2 Tension test reports shall include breaking load of test bars, machined diameter of test bars, and calculated tensile strength. Section **11** provides details of the test bar dimensions.

5.1.3 Analysis of castings or test bars after the time of production shall not be used as evidence of compliance to this specification.

## 6. Chemical Test for Gray Iron

6.1 The manufacturer shall perform tests to determine the significant chemical constituents of the gray iron used in the

manufacture of gray iron soil pipe fittings. Analysis shall be performed at a minimum of once per lot as defined in this specification. The manufacturer shall maintain a record of chemical tests performed for a minimum of seven years. The test results shall conform to the following requirements as to chemical composition:

Phosphorous (P)	0.38 % maximum
Sulfur (S)	0.15 % maximum
Chromium (Cr)	0.50 % maximum
Titanium (Ti)	0.10 % maximum
Aluminum (Al)	0.50 % maximum
Lead (Pb)	0.015 % maximum
Carbon Equivalent	4.10 % minimum by mass

Note: Carbon equivalent for gray iron = %C+%Si/3+%P/3.

6.1.1 Chemical tests shall be performed at the time of production of the castings covered by this specification.

6.1.2 Analysis of castings after the time of production shall not be used as evidence of compliance to this specification.

## 7. Dimensions and Permissible Variations

7.1 *Dimensions of Fittings*—All fittings shall conform to the dimensions and tolerances specified in **Table 1** and **Fig. 1** as applicable. Fittings not listed shall conform to **Table 1** for wall thickness and dimension *R* for the minimum radius of any drain inlets that any such fittings provide. Stack fittings and special fittings that perform the function of a sanitary tee, designed for the conveyance of soil or waste effluents, or both, shall have a radius not less than the following:

7.1.1 *Nominal Size of the Run or Branch*—Sizes 1½ to 2 in. shall have a minimum radius of 125 % of the smaller run or branch. Sizes 3 to 4 in. shall have a minimum radius of 100 % of the smaller run or branch. Sizes 5 to 6 in. shall have a minimum radius of 80 % of the smaller run or branch. Sizes 8 to 10 in. shall have a minimum radius of 70 % of the smaller run or branch.

7.2 *Ends of Fittings*—Spigot beads and positioning lugs as shown in **Fig. 1** are optional. Positioning lugs and spigot beads shall be as described in **Fig. 1** or continuous around circumference of the fitting when the manufacturer chooses to cast on the fittings. It is permissible to increase the wall thickness on the inside surface of fitting ends to reduce breakage. The increased thickness shall not reduce the minimum *B* dimension in **Table 1** in excess of 0.06 in. and shall not extend more than 4¼ in. from the plain end. The increased thickness shall be tapered and shall offer no obstruction to flow.

## 8. Methods of Specifying Fittings

8.1 *Method of Specifying Sizes of Fittings of More Than One Size*—The sizes shall be designated by the order of listing, as follows:

8.1.1 *Branch and Tapped Fittings*:

8.1.1.1 *Size of Run*—The run shall be that portion of the fitting that forms part of the main pipe line.

8.2 *Methods of Specifying Hand of Fittings with Side Inlets*—When placed in the position described below, if the side inlet appears on the right, it shall be a right-hand fitting; if on the left, it shall be a left-hand fitting.

**TABLE 1 Dimensions and Tolerances in Inches (Millimetres) of Spigots and Barrels for Hubless Fittings**

Size	Barrel		Spigot		Barrel Thickness, T		Gasket Positioning Lug <sup>A</sup> W
	Inside Diameter B	Outside Diameter J	Outside Diameter M	Bead Width <sup>A</sup> N, ±0.13 (3.3)	Nominal	Minimum	
2	(38.1 ± 2.29)	(48.26 ± 1.52)	(49.78 ± 1.52)	(6.35)	0.16	(3.3)	(28.7)
	1.96 ± 0.09	2.35 ± 0.09	2.41 ± 0.09	0.25		0.13	1.13
3	(49.8 ± 2.29)	(59.69 ± 2.29)	(61.21 ± 2.29)	(6.35)	0.16	(3.3)	(28.7)
	2.96 ± 0.09	3.35 ± 0.09	3.41 ± 0.09	0.25		0.13	1.13
4	(75.2 ± 2.29)	(85.09 ± 2.29)	(86.61 ± 2.29)	(6.35)	0.19	(3.3)	(28.7)
	3.94 ± 0.09	4.38 ± 0.09	4.44 ± 0.09	0.31		0.15	1.13
5	(100.08 ± 2.29)	(111.25 ± 2.29)	(112.78 ± 2.29)	(7.87)	0.19	(3.81)	(28.7)
	4.94 ± 0.09	5.30 ± 0.09	5.36 ± 0.09	0.31		0.15	1.50
6	(125.48 ± 2.29)	(134.62 ± 2.29)	(136.14 ± 2.29)	(7.87)	0.19	(3.81)	(38.1)
	5.94 ± 0.09	6.30 ± 0.09	6.36 ± 0.09	0.31		0.15	1.50
8	(150.88 ± 2.29)	(160.02 ± 2.29)	(161.54 ± 2.29)	(7.87)	0.23	(3.81)	(38.1)
	7.94 ± 0.13	8.38 ± 0.09	8.44 ± 0.09	0.31		0.17	2.00
	(201.68 ± 3.3)	(212.85 ± 3.3)	(214.38 ± 2.29)	(7.87)		(4.32)	(50.8)

<sup>A</sup> See Fig. 1 for details of the spigot and gasket positioning lug.

8.2.1 *Branch Fittings*—The branch shall be placed toward the observer and the outlet end of the run lower than the branch.

## 9. Coating

9.1 The fittings shall be uniformly coated with a material suitable for the purpose that is adherent and not brittle. The coating shall be applied in accordance with the coating manufacturer's requirements. External touch marks from points of contact during the coating process are permitted. The coating shall not contain asbestos above current SDS reportable levels. (The Global Harmonized System of classification and labeling of chemicals sets the same rules for classifying hazards and mandates the same format and content for labels and Safety Data Sheets around the world.) Safety Data Sheets shall be furnished by the coating manufacturer when requested. The coating shall be evenly and smoothly applied to all surfaces, except in threaded openings, unless the coating is specifically designed for threaded openings.

9.2 Fittings shall not be coated with paint containing lead which exceeds levels above 0.06 % (600 PPM).

9.2.1 The coating manufacturer shall annually prepare and submit samples to a qualified laboratory for tests in accordance with Practice E1645. The manufacturer shall prepare and submit samples when changing sources of supply or the coating manufacturer changes formulations for the coating.

9.3 Fittings coatings shall not contain levels of volatile organic hazardous air pollutants (VOHAPs) which exceed levels of 2.6 lb (0.31 kg/L) of VOHAPs per gallon of solids in accordance with Practice D3960.

9.3.1 The manufacturer shall annually certify that the coating meets the VOHAP requirement. It is permissible for the coating manufacturer to provide the certification.

9.4 Records shall be maintained for a period of seven years.

9.5 Copies of the coating certification shall be furnished when requested.

## 10. Sampling

10.1 Chemical and mechanical tests shall be made regularly and at sufficiently close intervals for adequate determinations of the significant chemical constituents and properties of the cast iron. Records of chemical analysis shall be maintained by the manufacturer. Copies of these analyses shall be furnished to the purchaser when requested.

10.2 A lot shall consist of all the metal poured for a given period of time between changes in charge, processing conditions, aim-for chemistry, or 4 h, whichever is the shorter period.

## 11. Test Methods

### 11.1 Gray Iron:

11.1.1 *Tensile Strength Test*—Test bars shall be cast in accordance with the requirements of Specification A48/A48M. The machined test bar dimensions and drawings and dimensions of as-cast test bars are found in Figs. 2-4. The tensile strength shall be determined in accordance with Test Methods E8/E8M.

11.1.2 Tension test reports shall include breaking load of test bars, machined diameter of test bars, and calculated tensile strength.

## 12. Inspection

12.1 *Inspection and Test by the Manufacturer*—Fittings shall be inspected to verify compliance with this specification. The manufacturer shall maintain a record of all inspections.

12.2 *Fitting Inspection*—At regular intervals (not to exceed 12 h) during the course of production, sample pieces of each size and configuration of fitting being produced shall be

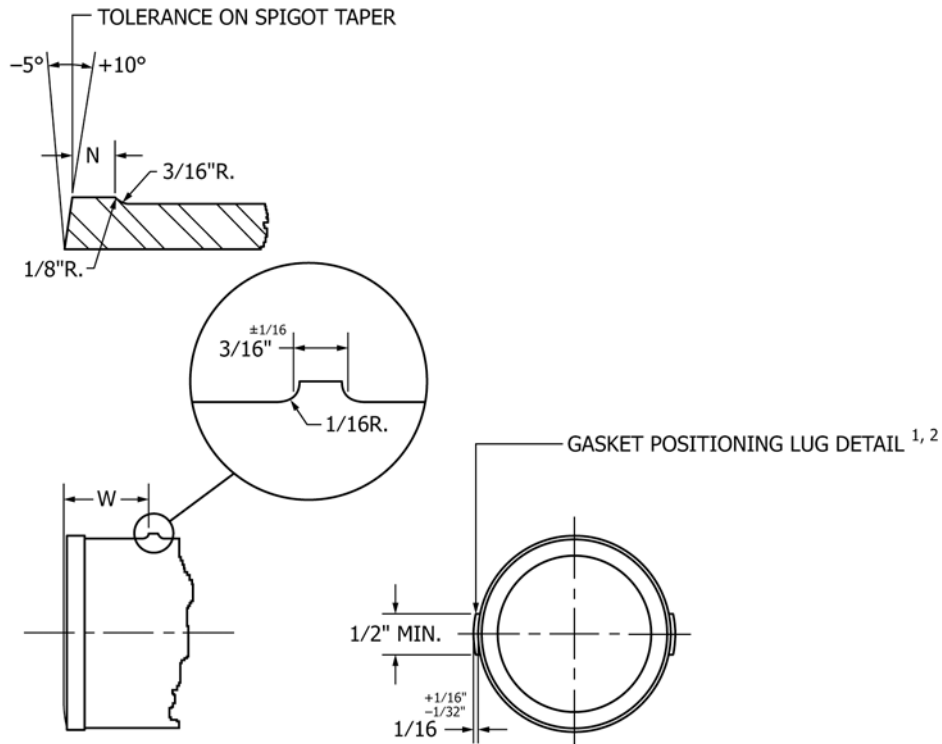

NOTE 1—These lugs and spigot beads are optional on all fittings. When a manufacturer chooses to utilize positioning lugs and spigot beads as illustrated above, these lugs and spigot beads shall be cast as illustrated or be continuous around the entire circumference.

NOTE 2—Gasket positioning lugs are optional on all fittings. When a manufacturer chooses to use positioning lugs as illustrated above, these lugs shall be cast as illustrated or be continuous around the entire circumference.

Size, in.	Spigot Detail, N, in. (mm)	Gasket Lug Location, W, in. (mm)
2	±0.13 (3.3)	±0.13 (3.3)
3	0.25 (6)	1.13 (29)
4	0.25 (6)	1.13 (29)
5	0.31 (8)	1.13 (29)
6	0.31 (8)	1.50 (38)
8	0.31 (8)	1.50 (38)

FIG. 1 Details of Spigot Bead and Gasket Positioning Lug

selected randomly for inspection. Each fitting selected shall be measured by suitable gages to verify that the laying length (as detailed in Figs. 3 and 4), and all applicable dimensions detailed in Table 1 and Fig. 1 comply with the requirements of this specification. The inspection records shall be maintained by the manufacturer for a period of seven years.

12.3 *Marking Inspection*—Inspection shall include verification that the markings on fittings comply with Section 14.

**13. Certification**

13.1 Upon request the purchaser, design professional, or the administrative authority having jurisdiction where these products are being installed shall be furnished certification by the manufacturer stating samples representing each lot have been tested and inspected as indicated in this specification and the requirements have been met. If required by the purchaser, certification shall be accompanied by test reports as prepared in accordance with Sections 11 and 12. Tension test reports shall include breaking load machined diameters of test bars and

calculated tensile strength. Certification shall include legal name and address of the manufacturer.

**14. Product Marking**

14.1 Each fitting shall be plainly marked with the country of origin and the manufacturer’s name or registered trademark by which the manufacturer can be readily identified after installation. The marking shall be adequate for identification of the manufacturer of the fittings if it readily identifies the manufacturer to the end user of the product.

14.2 On fittings, the marking shall be cast with raised letters that are not to be located within the W dimension, as shown in Fig. 1. Cast markings shall be raised from the wall of the fitting.

**15. Packaging and Package Marking**

15.1 *Government Procurement*—Unless otherwise specified in the contract, the material shall be packaged in accordance with the supplier’s standard practice, which will be acceptable

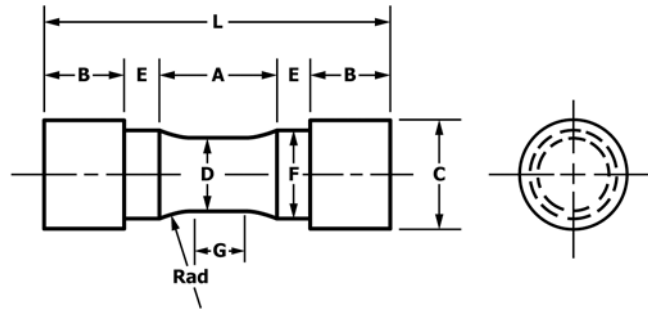

Dimensions, in. (mm)  
 G – Length of parallel, min  
 D – Diameter  
 R – Radius of fillet, min  
 A – Length of reduced section, min  
 L – Overall length, min  
 C – Diameter of end section, approx  
 E – Length of shoulder, min  
 F – Diameter of shoulder  
 B – Length of end section

Tension Test Specimen B  
 0.75 (19)  
 0.750 ± 0.015 (19.0 ± 0.38)  
 1 (25)  
 1½ (38)  
 4 (100)  
 1¼ (32)  
 ¼ (6)  
 15/16 ± 1/64 (25 ± 0.4)  
 See Footnote<sup>A</sup>

<sup>A</sup> Optional to fit holders on testing machine. If threaded, root diameter shall not be less than dimension F.

Test Bar	Nominal (Mid-Length)	As-Cast Diameter, in. (mm)		Minimum (Specified)	Length, in. (mm) Maximum (Recommended)
		Minimum (Bottom)	Maximum (Top)		
B	1.20 (30.5)	1.14 (29.0)	1.32 (33.5)	6.0 (150)	9.0 (230)

FIG. 2 Sample Test Bar

to the carrier at lowest rates. Containers and packing shall comply with Uniform Freight Classification Rules or National Motor Freight Classification Rules. Marking for shipment of such material shall be in accordance with Federal Standard No. 123 for civil agencies and MIL-STD-129 for military agencies.

16. Keywords

16.1 aerator; cast iron; de-aerator; hubless fittings; no-hub fittings; soil pipe fittings

ASTM A1109-22

<https://standards.iteh.ai/catalog/standards/sist/7b3c1cd2-0d4e-4d26-bdc3-cda27f30c5af/astm-a1109-22>