



Designation: **D7291/D7291M – 15 D7291/D7291M – 22**

Standard Test Method for Through-Thickness “Flatwise” Tensile Strength and Elastic Modulus of a Fiber-Reinforced Polymer Matrix Composite Material¹

This standard is issued under the fixed designation D7291/D7291M; the number immediately following the designation indicates the year of original adoption or, in the case of revision, the year of last revision. A number in parentheses indicates the year of last reappraisal. A superscript epsilon (ϵ) indicates an editorial change since the last revision or reappraisal.

1. Scope

1.1 This test method determines the through-thickness “flatwise” ~~tension~~ tensile strength and elastic modulus of fiber reinforced polymer matrix composite materials. A tensile force is applied normal to the plane of the composite laminate using adhesively bonded thick metal end-tabs. The composite material forms are limited to ~~continuous fiber or discontinuous fiber (tape or 2-dimensional fabric, or both)~~ continuous fiber (unidirectional reinforcement or two-dimensional fabric) or discontinuous fiber (nonwoven or chopped) reinforced composites.

1.2 The through-thickness strength results using this test method will in general not be comparable to Test Method D6415 since this method subjects a relatively large volume of material to an almost uniform stress field while Test Method D6415 subjects a small volume of material to a non-uniform stress field.

1.3 Units—The values stated in either SI units or inch-pound units are to be regarded separately as standard. ~~Within the text, the inch-pound units are shown in brackets. The values stated in each system are not necessarily exact equivalents; therefore, to ensure conformance with the standard, each system must shall be used independently of the other. Combining together, and values from the two systems may result in nonconformance with the standard shall not be combined.~~

1.3.1 Within the text, the inch-pound units are shown in brackets.

1.4 This standard may involve hazardous materials, operations, and equipment.

1.5 *This standard does not purport to address all of the safety ~~problems, concerns,~~ if any, associated with its use. It is the responsibility of the user of this standard to establish appropriate ~~safety~~ safety, health, and ~~health~~ environmental practices and determine the applicability of regulatory limitations prior to use.*

1.6 *This international standard was developed in accordance with internationally recognized principles on standardization established in the Decision on Principles for the Development of International Standards, Guides and Recommendations issued by the World Trade Organization Technical Barriers to Trade (TBT) Committee.*

¹ This test method is under the jurisdiction of ASTM Committee D30 on Composite Materials and is the direct responsibility of Subcommittee D30.06 on Interlaminar Properties.

Current edition approved Oct. 1, 2015; Oct. 15, 2022. Published November 2015; November 2022. Originally approved in 2007. Last previous edition approved in 2007; 2015 as D7291/D7291M; D7291/D7291M – 15. -07. DOI: 10.1520/D7291-15; 10.1520/D7291-22.



2. Referenced Documents

2.1 ASTM Standards:²

- D792 Test Methods for Density and Specific Gravity (Relative Density) of Plastics by Displacement
- D883 Terminology Relating to Plastics
- [D2584 Test Method for Ignition Loss of Cured Reinforced Resins](#)
- [D2651 Guide for Preparation of Metal Surfaces for Adhesive Bonding](#)
- [D2734 Test Methods for Void Content of Reinforced Plastics](#)
- D3171 Test Methods for Constituent Content of Composite Materials
- D3878 Terminology for Composite Materials
- D5229/D5229M Test Method for Moisture Absorption Properties and Equilibrium Conditioning of Polymer Matrix Composite Materials
- D5687/D5687M Guide for Preparation of Flat Composite Panels with Processing Guidelines for Specimen Preparation
- D6415 Test Method for Measuring the Curved Beam Strength of a Fiber-Reinforced Polymer-Matrix Composite
- E4 Practices for Force Calibration and Verification of Testing Machines
- E6 Terminology Relating to Methods of Mechanical Testing
- E122 Practice for Calculating Sample Size to Estimate, With Specified Precision, the Average for a Characteristic of a Lot or Process
- E177 Practice for Use of the Terms Precision and Bias in ASTM Test Methods
- E251 Test Methods for Performance Characteristics of Metallic Bonded Resistance Strain Gages
- E456 Terminology Relating to Quality and Statistics
- E691 Practice for Conducting an Interlaboratory Study to Determine the Precision of a Test Method
- E1012 Practice for Verification of Testing Frame and Specimen Alignment Under Tensile and Compressive Axial Force Application
- ~~E1309 Guide for Identification of Fiber-Reinforced Polymer-Matrix Composite Materials in Databases (Withdrawn 2015)³~~
- ~~E1434 Guide for Recording Mechanical Test Data of Fiber-Reinforced Composite Materials in Databases (Withdrawn 2015)³~~
- ~~E1471 Guide for Identification of Fibers, Fillers, and Core Materials in Computerized Material Property Databases (Withdrawn 2015)³~~

3. Terminology

3.1 *Definitions*—Terminology D3878 defines terms relating to high-modulus fibers and their composites. Terminology D883 defines terms relating to plastics. Terminology E6 defines terms relating to mechanical testing. Terminology E456 and Practice E177 define terms relating to statistics. In the event of a conflict between terms, Terminology D3878 shall have precedence over the other terminologies. terminology standards.

NOTE 1—If the term represents a physical quantity, its analytical dimensions are stated immediately following the term (or letter symbol) in fundamental dimension form, using the following ASTM standard symbology for fundamental dimensions, shown within square brackets: $[M]$ for mass, $[L]$ for length, $[T]$ for time, $[Θ]$ for thermodynamic temperature, and $[nd]$ for non-dimensional quantities. Use of these symbols is restricted to analytical dimensions when used with square brackets, as the symbols may have other definitions when used without the brackets.

3.2 Definitions of Terms Specific to This Standard:

3.2.1 *flatwise tensile ultimate strength*, F^m $[M L^{-1} T^{-2}]$, n —the ultimate strength of the composite material in the out-of-plane (through-thickness) direction.

3.2.2 *through-thickness tensile modulus*, E^{chord} $[M L^{-1} T^{-2}]$, n —the chord modulus of elasticity of the composite material in the out-of-plane (through-thickness) direction.

3.3 Symbols:

3.3.1 A —cross-sectional area of specimen in the through-thickness direction,

3.3.2 CV —coefficient of variation statistic of a sample population for a given property (in percent),

3.3.3 E^{chord} — through-thickness tensile modulus.

² For referenced ASTM standards, visit the ASTM website, www.astm.org, or contact ASTM Customer Service at service@astm.org. For *Annual Book of ASTM Standards* volume information, refer to the standard's Document Summary page on the ASTM website.

3.3.4 F^tu — flatwise tensile ultimate strength.

3.3.5 n —number of specimens.

3.3.6 P_{max} —maximum force carried by test specimen before failure.

3.3.7 $s_{\bar{X}_{n-1}}$ —sample standard deviation: standard deviation statistic of a sample population for a given property.

3.3.8 x_i —measured or derived property for an individual specimen from the sample population.

3.3.9 \bar{x} —sample mean (average).

3.3.10 ϵ —indicated through-thickness tensile strain from strain transducer.

3.3.11 σ —through-thickness tensile stress.

4. Summary of Test Method

4.1 A composite specimen in the shape of either a straight-sided cylindrical disk or a reduced gage section cylindrical “spool” is adhesively bonded to cylindrical metal end tabs. The bonded assembly is loaded under “flatwise” tension loading by a force applied normal to the plane of the composite laminate until failure of the laminate occurs (Fig. 1). The test is considered valid only when failure occurs entirely within the composite laminate. The test is considered invalid if failure of the bond-line, or partial failure of the bond-line and the surface layer of the composite, occurs. The failure mode of this test is not controlled; therefore, the actual failure may be intralaminar or interlaminar in nature.

4.2 If force-strain data are required, the specimen may be instrumented with strain gages provided certain specimen thickness requirements are satisfied (see 8.2).

5. Significance and Use

5.1 This test method is designed to produce through-thickness failure data for structural design and analysis, quality assurance, and research and development. Factors that influence the through-thickness tensile strength, and should therefore be reported, include the following: material and fabric reinforcement, methods of material and fabric preparation, methods of processing and specimen fabrication, specimen stacking sequence, specimen conditioning, environment of testing, specimen alignment, speed of testing, time at temperature, void content, and volume reinforcement content.

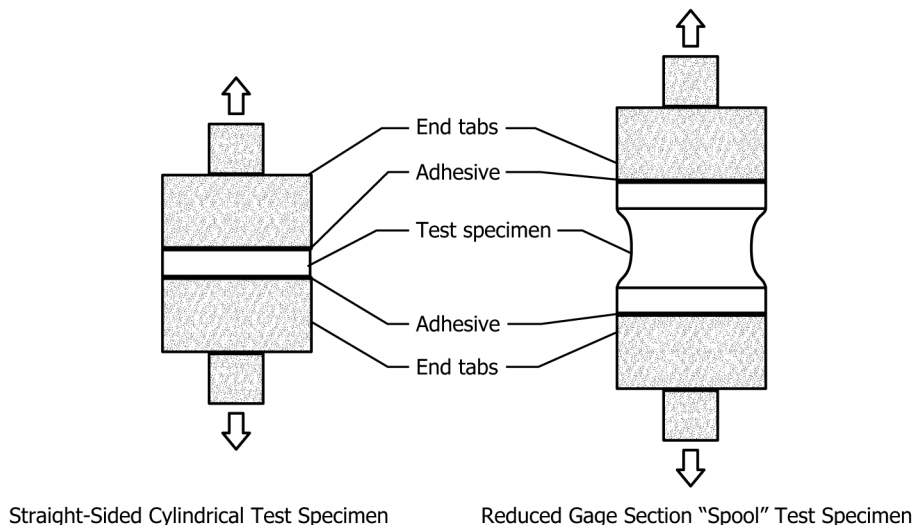

FIG. 1 Flatwise Tension Specimen and End Tab Assembly



6. Interferences

6.1 *Material and Specimen Preparation*—Poor material fabrication practices, lack of control of fiber alignment, voids, and damage induced by improper specimen machining are known causes of high material data scatter in composites in general. In addition, surface finish of the cylindrical machined surface and lack of control of parallelism of laminate surfaces can lead to erroneous through-thickness strength results. Laminate stacking sequences that are not balanced and symmetric could lead to adhesive bondline failures.

6.2 *Material with Coarse Structure*—This test method assumes that the material is relatively homogeneous with respect to the size of the test section. Certain fabric and braided composites with large repeating unit cell sizes ($>12\text{ mm}$ [0.5 in.]) ($>12\text{ mm}$ [0.5 in.]) should not be tested with this specimen size. It may be possible to scale-up the specimen size and fixtures to accommodate such materials, but this is beyond the scope of this test method.

6.3 *Load Eccentricity*—Bending of the specimen during loading can occur, affecting strength results. Bending may occur due to poor specimen preparation, non-parallel laminate surfaces, improper bonding of the specimen to the end tabs, or machine/load train misalignment.

6.4 *Void content—Content*—The through-thickness ~~tension~~tensile strength measured using this method is extremely sensitive to reinforcement volume and void content. Consequently, the test results may reflect manufacturing quality as much as material properties.

7. Apparatus

7.1 *Micrometers—~~Micrometers and Calipers~~*—~~The micrometer(s) shall use a 4 to 6 mm–8 mm [0.16 to 0.25 in.] diameter ball-interface on irregular surfaces such as the bag-side of a laminate, and 0.32 in.] nominal diameter ball-interface or a flat anvil interface shall be used to measure the specimen thickness. A ball interface is recommended for thickness measurements when at least one surface is irregular (for example, a coarse peel ply surface which is neither smooth nor flat). A micrometer or caliper with a flat anvil interface on machined or very-smooth tooled surfaces. The shall be used for measuring length, width, and other machined surface dimensions. The use of alternative measurement devices is permitted if specified (or agreed to) by the test requestor and reported by the testing laboratory. The accuracy of the instrument(s) shall be suitable for reading to within 1 % of the sample diameter and thickness. specimen dimensions. For typical specimen geometries, an instrument with an accuracy of $\pm 25\text{ }\mu\text{m}$ [$\pm 0.001\text{ in.}$] is desirable for both diameter and thickness measurements. $\pm 0.0025\text{ mm}$ [$\pm 0.0001\text{ in.}$] is adequate for thickness measurements, while an instrument with an accuracy of $\pm 0.025\text{ mm}$ [$\pm 0.001\text{ in.}$] is adequate for measurement of length, width, other machined surface dimensions.~~

7.2 *Fixtures*—The apparatus consists of three different fixtures.

7.2.1 The loading fixtures are used to load the specimen and end tab assembly. They can be either self-aligning or fixed grip and shall not apply eccentric loads.

7.2.2 The end tabs are bonded to the specimen (Figs. 2 and 3). The end tabs are attached to the loading fixture during the test. The threads on the end tabs provide a means to attach the specimen and end tab assembly to the loading fixture. They also provide a means to attach constant diameter bushings for the purpose of aligning the specimen and end tab assembly in the bonding fixture. The end tab thickness shall be a minimum of 12.7 mm [0.5 in.]. ~~Section~~Subsection 8.3 provides further requirements for the end tabs.

7.2.3 The end tab bonding fixture (Figs. 4-6) is used to provide support and alignment to the specimen and end tab assembly during the entire bonding process. The threads on the end tabs are used to attach bushings to them during the bonding process. These bushings provide a fixed diameter reference surface for aligning the specimen and end tab assembly during bonding, thus allowing the ~~reuse~~re-use and re-machining of the end tabs.

7.3 *Testing Machine*—The testing machine shall conform with Practice E4, and shall satisfy these requirements:

7.3.1 *Testing Machine Heads*—The testing machine shall have two crossheads, with either a stationary head and a movable head or two movable heads.

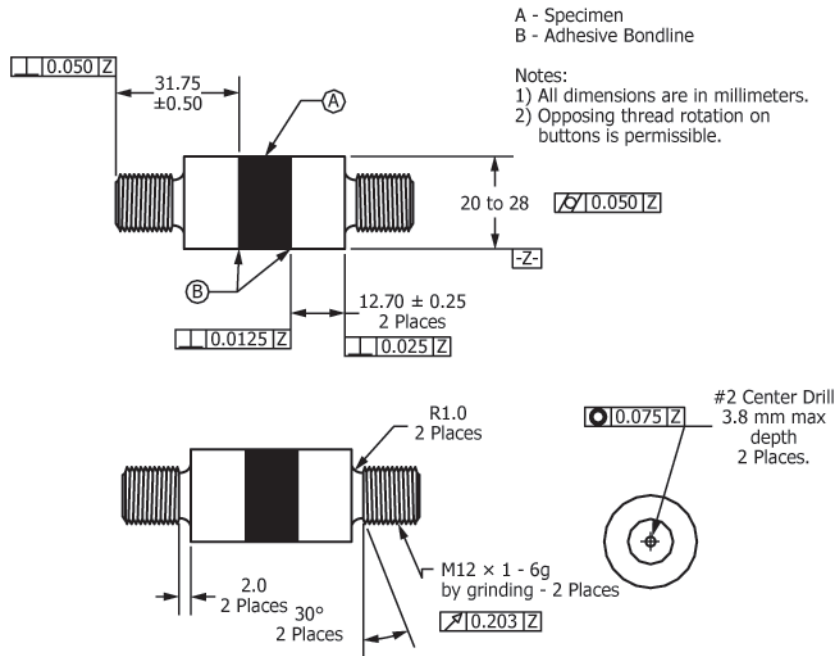

FIG. 2 Drawing of End Tabs and Cylindrical Specimen Assembly (SI units)

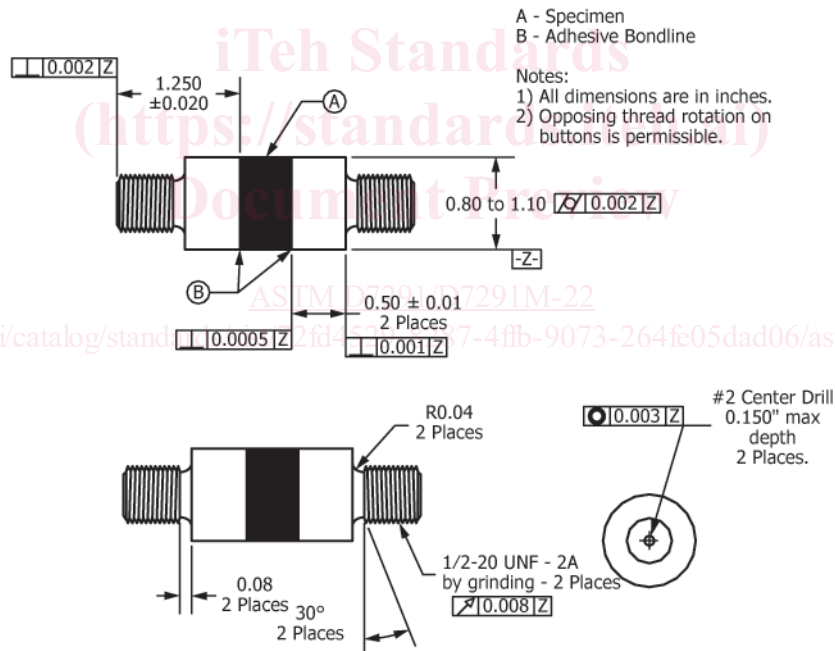

FIG. 3 Drawing of End Tabs and Cylindrical Specimen Assembly (inch-pound units)

7.3.2 *Platens/Adapter*—One of the testing machine heads shall be capable of being attached to the lower half of the specimen end tab by an adapter or platen interface as required. The other head shall be capable of being attached to the upper half of the specimen end tab.

7.3.3 *Drive Mechanism*—The testing machine drive mechanism shall be capable of imparting to the movable head a controlled velocity with respect to the stationary head. The velocity of the movable head shall be capable of regulation as specified in 11.3.

7.3.4 *Force Indicator*—The testing machine force-sensing device shall be capable of indicating the total force applied to the test specimen. This device shall be essentially free from response lag at the specified testing rate and shall indicate the force with an

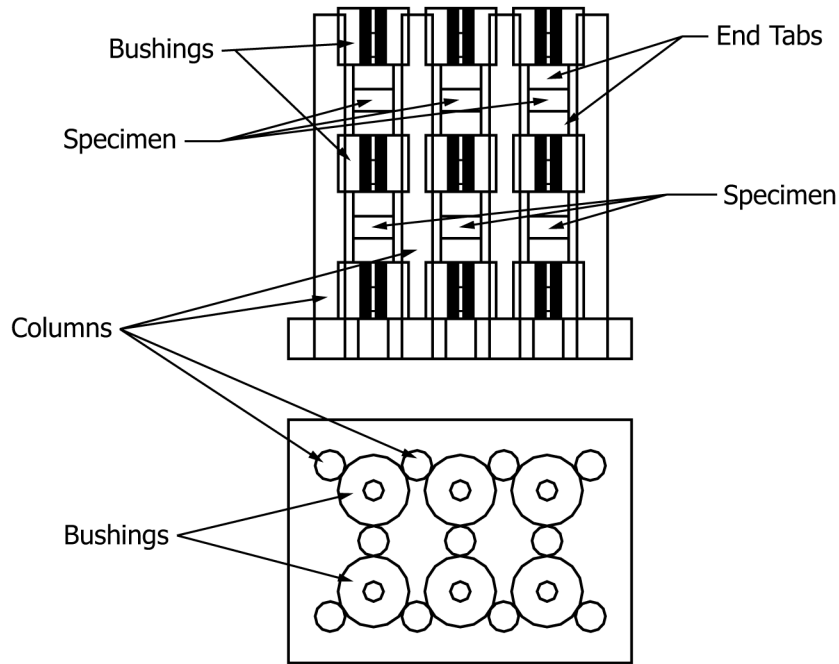

FIG. 4 Drawing of Alignment and Bonding Fixture (showing 12 specimens)

- Notes:
- 1) Dimensional Tolerance on all Pin Location Holes is ± 0.025 mm
 - 2) Material: Steel Rc54
 - 3) Chamfer all edges 1.0 mm

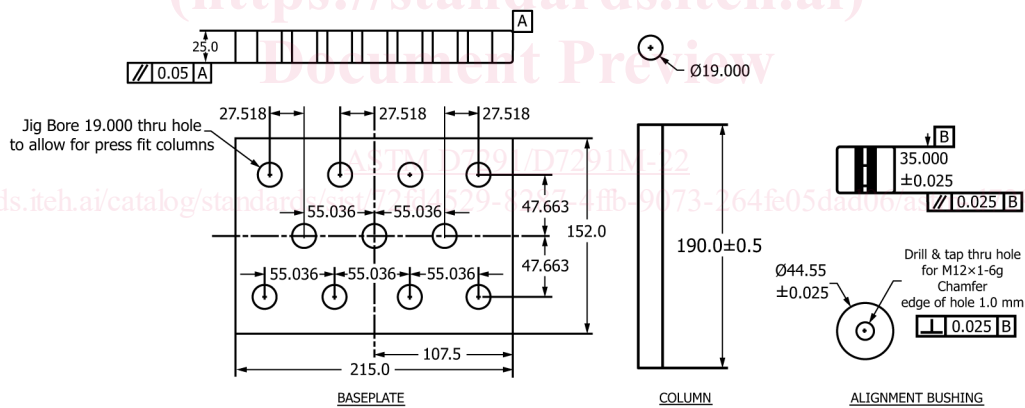

FIG. 5 Drawing of Alignment and Bonding Fixture (SI units)

accuracy over the load range(s) of interest of within ± 1 % of the indicated value, as specified by Practice E4. The load range(s) of interest may be fairly low for modulus evaluation, much higher for strength evaluation, or both, as required.

7.4 Force versus Displacement Record—An X-Y plotter, or similar device, shall be used to make a permanent record of the force versus displacement during the test. Alternatively, the data may be stored digitally and post-processed.

7.5 Strain-Indicating Device—For the measurement of through-thickness modulus, bonded resistance strain gages shall be used to measure strain. Either two strain gages at locations that are 180 degrees apart or three strain gages at 120 degrees apart are required around the cylindrical surface of the specimen at the center of the gage section.

7.5.1 Bonded Resistance Strain Gages—Strain gage selection is a compromise based on the type of material. An active gage length of 1.5 mm [0.062 in.] is recommended for most materials, although larger gages may be more suitable for some woven fabrics (with consolidated tow thicknesses larger than 1.5 mm [0.062 in.]), provided the specimen gage length can accommodate such

- Notes:
 1) Dimensional Tolerance on all Pin Location Holes is ± 0.001 "
 2) Material: Steel Rc54
 3) Chamfer all edges 0.05"

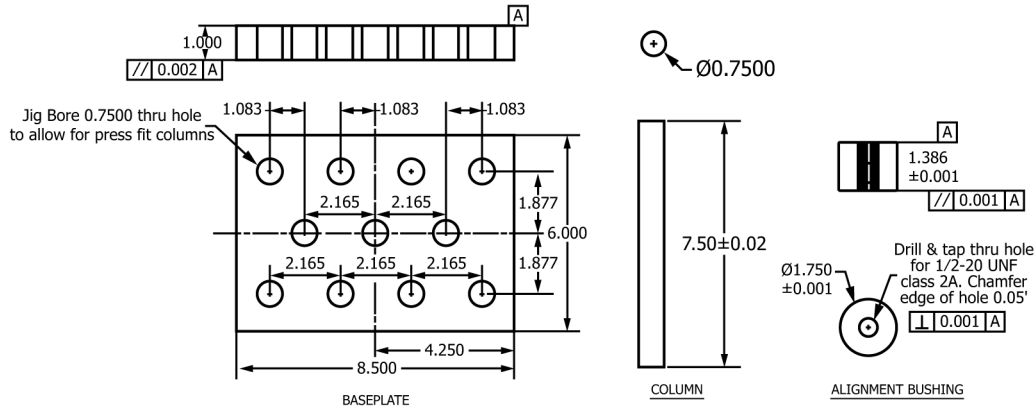

FIG. 6 Drawing of Alignment and Bonding Fixture (inch-pound units)

gages (as specified in 8.2). Gage calibration certification shall comply with Test Method E251. For laminated composites, the strain gage should cover a minimum of three laminate plies.

7.6 System Alignment—Poor system alignment can be a major contributor to premature failure, to elastic property data scatter, or both. Practice E1012 describes bending evaluation guidelines and describes potential sources of misalignment during tensile testing. Alignment should be checked using a cylindrical metal specimen with a minimum of three strain gages equally spaced around the circumference per Practice E1012. While the maximum advisable amount of system misalignment is material and location dependent, good testing practice is generally able to limit percent bending to within 5 % at moderate strain levels ($>1000 \mu\epsilon$). A system showing excessive bending for the given application should be re-adjusted or modified.

7.7 Conditioning Chamber—When conditioning materials in other than ambient laboratory at non-laboratory environments, a temperature/vapor-level/temperature-level/vapor-level controlled environmental conditioning chamber is required, required that shall be capable of maintaining the required relative temperature to within $\pm 3^\circ\text{C}$ [$\pm 5^\circ\text{F}$] and the required relative vapor level to within $\pm 3\%$. Chamber conditions shall be monitored either on an automated continuous basis or on a manual basis at regular intervals.

7.8 Environmental Test Chamber—An environmental test chamber is required for test environments other than ambient testing laboratory conditions. This chamber shall be capable of maintaining the gage section of the test specimen within $\pm 3^\circ\text{C}$ [$\pm 5^\circ\text{F}$] of test specimen and fixture at the required test temperature environment during the mechanical test. The test temperature shall be maintained within $\pm 3^\circ\text{C}$ [$\pm 5^\circ\text{F}$] of the required temperature, and, if specified by the requestor, the relative humidity level shall be maintained to within $\pm 3\%$ RH of the required humidity level. In addition, the chamber may have to be capable of maintaining environmental conditions such as fluid exposure or relative humidity during the test (see 11.4).

8. Sampling and Test Specimens

8.1 Sampling—Test at least five specimens per test condition unless valid results can be gained through the use of fewer specimens, such as in the case of a designed experiment. Consult For statistically significant data, the procedures outlined in Practice E122 to determine statistically appropriate sample sizes, should be consulted. The method of sampling shall be reported.

8.2 Geometry—The coupons are cylindrical with either a constant cross-sectional area (Figs. 2 and 3) or a reduced gage section (Figs. 7 and 8). The nominal diameter where the specimen is bonded to the metal end tabs, for both specimen types, is 25 mm [1.0 in.]. However, this diameter can be in the range of 20 to 28 mm [0.8 to 1.1 in.] to allow the re-use and re-machining of the end tabs. For through-thickness failure stress measurement, the minimum specimen thickness shall be 2.5 mm [0.1 in.]. For the measurement of through-thickness strains and modulus, the minimum specimen thickness shall be 6 mm [0.25 in.]. The reduced gage section geometry is often used for materials that have a through-thickness strength that approaches the bond strength of the adhesive. This is also the preferred geometry for laminates that are at least 25 mm [1.00 in.] thick.