



Designation: D7873 – 22a

# Standard Test Method for Determination of Oxidation Stability and Insolubles Formation of Inhibited Turbine Oils at 120 °C Without the Inclusion of Water (Dry TOST Method)<sup>1</sup>

This standard is issued under the fixed designation D7873; the number immediately following the designation indicates the year of original adoption or, in the case of revision, the year of last revision. A number in parentheses indicates the year of last reapproval. A superscript epsilon (ε) indicates an editorial change since the last revision or reapproval.

## 1. Scope\*

1.1 This test method is used to evaluate the sludging tendencies of steam and gas turbine lubricants during the oxidation process in the presence of oxygen and metal catalyst (copper and iron) at an elevated temperature. This test method may be used to evaluate industrial oils (for example, circulating oils and so forth).

1.2 This test method is a modification of Test Method D4310 where the sludging and corrosion tendencies of the same kinds of oils are determined after 1000 h at 95 °C in the presence of water. Water is omitted in this modification.

1.3 The values stated in SI units are to be regarded as standard.

1.3.1 *Exception*—The values in parentheses in some of the figures are provided for information only for those using old equipment based on non-SI units.

1.4 *This standard does not purport to address all of the safety concerns, if any, associated with its use. It is the responsibility of the user of this standard to establish appropriate safety, health, and environmental practices and determine the applicability of regulatory limitations prior to use.*

1.5 **WARNING**—Mercury has been designated by many regulatory agencies as a hazardous substance that can cause serious medical issues. Mercury, or its vapor, has been demonstrated to be hazardous to health and corrosive to materials. Use Caution when handling mercury and mercury-containing products. See the applicable product Safety Data Sheet (SDS) for additional information. The potential exists that selling mercury or mercury-containing products, or both, is prohibited by local or national law. Users must determine legality of sales in their location.

1.6 *This international standard was developed in accordance with internationally recognized principles on standard-*

<sup>1</sup> This test method is under the jurisdiction of ASTM Committee D02 on Petroleum Products, Liquid Fuels, and Lubricants and is the direct responsibility of Subcommittee D02.09.0C on Oxidation of Turbine Oils.

Current edition approved Nov. 1, 2022. Published November 2022. Originally approved in 2013. Last previous edition approved in 2022 as D7873 – 22. DOI: 10.1520/D7873-22A.

*ization established in the Decision on Principles for the Development of International Standards, Guides and Recommendations issued by the World Trade Organization Technical Barriers to Trade (TBT) Committee.*

## 2. Referenced Documents

### 2.1 ASTM Standards:<sup>2</sup>

A510M Specification for General Requirements for Wire Rods and Coarse Round Wire, Carbon Steel (Metric) (Withdrawn 2011)<sup>3</sup>

B1 Specification for Hard-Drawn Copper Wire

D943 Test Method for Oxidation Characteristics of Inhibited Mineral Oils

D1193 Specification for Reagent Water

D2272 Test Method for Oxidation Stability of Steam Turbine Oils by Rotating Pressure Vessel

D4057 Practice for Manual Sampling of Petroleum and Petroleum Products

D4175 Terminology Relating to Petroleum Products, Liquid Fuels, and Lubricants

D4310 Test Method for Determination of Sludging and Corrosion Tendencies of Inhibited Mineral Oils

E1 Specification for ASTM Liquid-in-Glass Thermometers

E230/E230M Specification for Temperature-Electromotive Force (emf) Tables for Standardized Thermocouples

### 2.2 Other Standards:

Specification for IP Standard Thermometers<sup>4</sup>

ISO 3696 Water for Analytical Laboratory Use—Specification and Test Methods<sup>5</sup>

## 3. Terminology

### 3.1 Definitions:

<sup>2</sup> For referenced ASTM standards, visit the ASTM website, [www.astm.org](http://www.astm.org), or contact ASTM Customer Service at [service@astm.org](mailto:service@astm.org). For *Annual Book of ASTM Standards* volume information, refer to the standard's Document Summary page on the ASTM website.

<sup>3</sup> The last approved version of this historical standard is referenced on [www.astm.org](http://www.astm.org).

<sup>4</sup> Available from Energy Institute, 61 New Cavendish St., London, WIG 7AR, U.K., <http://www.energyinst.org>.

<sup>5</sup> Available from American National Standards Institute (ANSI), 25 W. 43rd St., 4th Floor, New York, NY 10036, <http://www.ansi.org>.

\*A Summary of Changes section appears at the end of this standard

3.1.1 See Terminology **D4175** for a list of terms relating to petroleum products, liquid fuels, and lubricants.

### 3.2 Definitions of Terms Specific to This Standard:

3.2.1 *sludge, n*—a precipitate or sediment from oxidized mineral oil that is insoluble in *n*-heptane.

## 4. Summary of Test Method

4.1 A total of six to eight tubes containing 360 mL of sample each are heated at 120 °C with oxygen in the presence of an iron-copper catalyst. Each tube is removed over time and the sample is analyzed by Test Method **D2272** and the insolubles are measured until the RPVOT residual ratio reaches below 25 % or an agreed-upon percentage or specified time. Test run for a specified time(s) may be run using a single tube or as many as specified by the requestor. The mass of insoluble material of each oil sample is determined gravimetrically by filtration of a 100 g oil sample through a membrane filter with pore size 1 µm. The insoluble mass (mg/kg oil) is plotted against RPVOT residual ratio. The insoluble mass in milligrams per kilogram oil at 25 % or an agreed-upon RPVOT residual ratio or specified time is reported.

## 5. Significance and Use

5.1 Insoluble material may form in oils that are subjected to oxidizing conditions.

5.2 Significant formation of oil insolubles or metal corrosion products, or both, during this test may indicate that the oil will form insolubles or corrode metals, or both, resulting in varnish formation during field service. The level of varnish formation in service will be dependent on many factors (turbine design, reservoir temperature, duty-cycle, for example, peaking, cycling, or base-load duty, maintenance, and so forth) and a direct correlation between results in this test and field varnish formation are yet to be established.

5.3 Oxidation condition at 120 °C under accelerated oxidation environment of Test Method **D4310** and measurement of sludge and RPVOT value could reflect a practical oil quality in actual turbine operations. Results from this test should be used together with other key lubricant performance indicators (including other established oxidation and corrosion tests) to indicate suitability for service.

## 6. Apparatus

6.1 *Oxidation Cell*, of borosilicate glass, as shown in **Fig. 1**, consisting of a test tube, condenser, and oxygen delivery tube. It is recommended to have a test tube with a calibration line at 360 mL (maximum error 1 mL). This calibration applies to the test tube without inserts at 20 °C.

6.2 *Heating Bath*, thermostatically controlled, capable of maintaining the oil sample in the oxidation cell at a temperature of 120 °C ± 0.5 °C, fitted with a suitable stirring device to provide a uniform temperature throughout the bath, and large enough to hold the desired number of oxidation cells immersed in the heating bath to a depth of 355 mm ± 10 mm. Heated metal block baths meeting the test method requirements may also be used.

6.2.1 Studies have suggested that direct sunlight or artificial light may adversely influence the results of this test. To

minimize effects of light exposure on the lubricant being tested, light shall be excluded from the lubricant by one or more of the following ways:

6.2.1.1 Use of heated liquid baths that are designed and constructed of metal, or combinations of metals and other suitable opaque materials, that prevent light from entering the test cell from the sides is preferred. If a viewing window is included in the design, this viewing window shall be fitted with a suitable opaque cover and be kept closed when no observation is being made.

6.2.1.2 If glass heating baths are used, the bath shall be wrapped with aluminum foil or other opaque material.

6.2.1.3 Bright light entering the test cell from directly overhead can be eliminated by use of an opaque shield.

6.3 *Flowmeter*, with a flow capacity of at least 3 L of oxygen/hour, and an accuracy of ±0.1 L/h.

6.4 *Heating Bath Thermometer*, ASTM Solvents Distillation Thermometer having a range from 98 °C to 152 °C and conforming to the requirements for Thermometer 41C as prescribed in Specification **E1**, or for Thermometer 81C as prescribed in Specifications for IP Standard Thermometers. Alternatively, temperature-measuring devices of equal or better accuracy and precision may be used.

6.5 *Oxidation Cell Thermometer*, A 76 mm immersion LIG having a range of 110 °C to 130 °C, graduated in 0.1 °C, total length of 300 mm ± 5 mm, and stem diameter of 6.0 mm to 7.0 mm. Alternatively, temperature-measuring devices or DCT, of equal or better accuracy and precision may be used. Temperature of the sample shall be measured at 76 mm from the top of the sample. See **Fig. 2** and **Fig. 3**.

NOTE 1—Temperature gradient within the sample may exist from the heating system and temperature control design.

6.6 *Wire Coiling Mandrel*, as shown in **Fig. 4**.

6.7 *Thermometer Bracket*, for holding the oxidation cell thermometer, of 18-8 stainless steel, having the dimensions shown in **Fig. 5**. The thermometer is held in the bracket by two fluoro-elastomer O-rings of approximately 5 mm inside diameter. Alternatively, thin stainless steel wire may be used.

6.8 *Abrasive Cloth*, silicon carbide, 100 grit with cloth backing.

6.9 *Flexible Tubing*, poly vinyl chloride approximately 6.4 mm (¼ in.) inside diameter with a 2.4 mm (¾ in.) wall for delivery of oxygen to the oxidation cell.

6.10 *Membrane Filters*, white, plain, 47 mm in diameter, pore size 1 µm. The recommended membrane filters are PTFE and cellulose acetate plus nitrocellulose material.

6.11 *Filter Holder*, 47 mm, consisting of a borosilicate glass funnel and a funnel base with a coarse grade fritted-glass filter support with a length of 40 µm to 60 µm, or stainless steel screen support such that the filter can be clamped between the ground-glass sealing surfaces of the funnel and its base by means of a metal clamp.

6.12 *Weighing Bottle*, cylindrical body with ground-glass stopper; approximate inside diameter 65 mm, height of body 45 mm, capacity 60 mL.

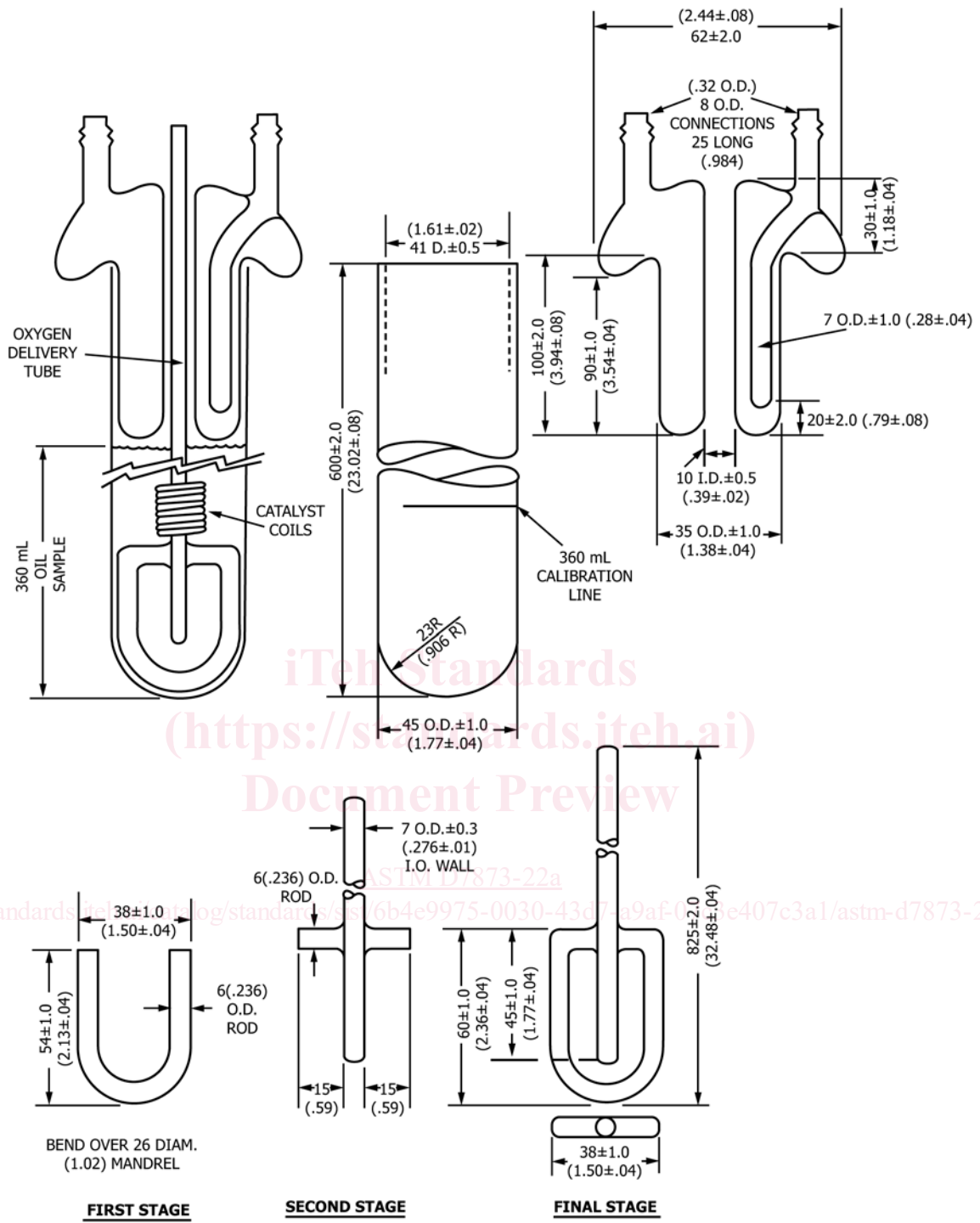

NOTE 1—All dimensions are in millimetres (inches).  
 NOTE 2—The oxidation test tube has a calibration line at 360 mL. This calibration applies to the test tube alone at 20 °C.  
 NOTE 3—Open tube ends to be ground and fire-polished.

FIG. 1 Oxidation Cell

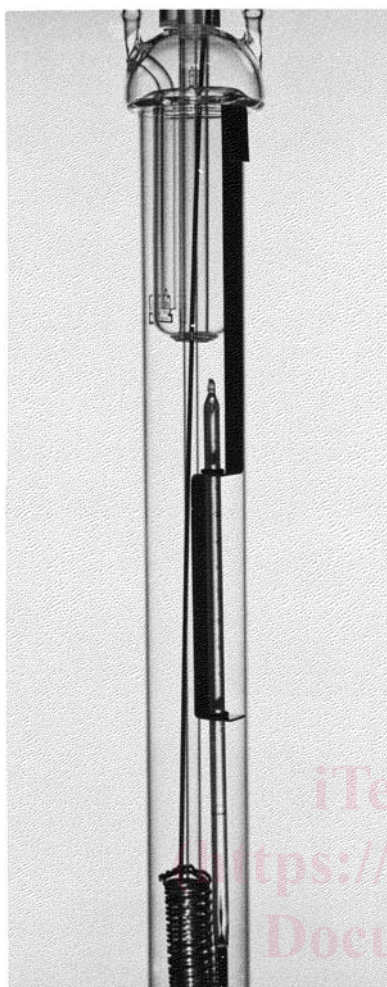

FIG. 2 Oxidation Cell with Thermometer

Typ: Range +110 to +130°C in 0,1°C

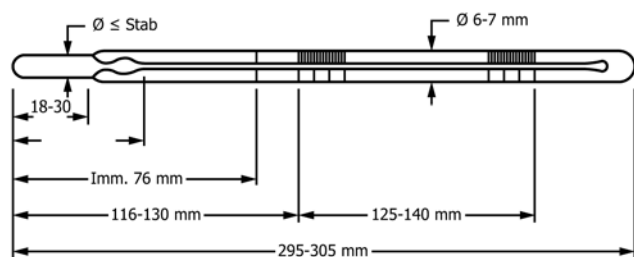

FIG. 3 76 mm Immersion LIG Thermometer

### 6.18 Pipette Bulb.

## 7. Reagents and Materials

7.1 *Purity of Reagents*—Reagent grade chemicals shall be used in all tests. Unless otherwise indicated, it is intended that all reagents shall conform to the specifications of the committee on Analytical Reagents of the American Chemical Society, where such specifications are available.<sup>6</sup>

7.2 *Reagent Water*, Unless otherwise indicated, reference to water shall be understood to mean distilled, deionized water as defined by Type I or Type II in Specification D1193 or Grade 3 in ISO 3696.

7.3 *Acetone*, Reagent grade. (**Warning**—Health hazard, flammable.)

7.4 *Cleaning Reagent*, cleaning by a 24 h soak at room temperature in a free rinsing liquid acid cleaner with a pH of 2 to 4.5.

7.5 *n-heptane*, Reagent grade. (**Warning**—Flammable. Harmful if inhaled.)

7.6 *Isopropyl Alcohol*, Reagent grade. (**Warning**—Flammable.)

### 7.7 Catalyst Wires,

7.7.1 *Low-Metalloid Steel Wire*—1.59 mm (0.0625 in.) in diameter (No. 16 Washburn and Moen Gage).

NOTE 2—Carbon steel wire, soft bright annealed and free from rust of Grade 1008 as described in Specification A510M is satisfactory. Similar wire conforming to Specification E230/E230M is also satisfactory

7.8 *Electrolytic Copper Wire*, 1.63 mm (0.064 in.) in diameter (No. 16 Imperial Standard Wire Gage or No. 14 American Wire Gage), 99.9 % purity, conforming to Specification B1.

NOTE 3—Alternatively, suitably prepared steel and copper catalyst coils may be purchased from a supplier.

7.9 *Detergent*, free rinsing, water-soluble, anionic detergent with a pH of 9.5 to 11.

7.10 *Oxygen*—(**Warning**—Oxygen vigorously accelerates combustion.) 99.5 % minimum purity, with pressure regulation adequate to maintain a constant flow of gas through the apparatus. The use of a two-stage pressure regulator on tank oxygen is recommended.

## 8. Sampling

8.1 Samples for this test can come from tanks, drums, small containers, or even operating equipment. Therefore, use the applicable apparatus and techniques described in Practice D4057.

8.2 For one single determination at a specified time the minimum required sample size is 360 mL. However, 6 to 8 tubes will be required to develop the data points to obtain the sludge mass at 25 % or agreed-upon residual RPVOT ratio by

<sup>6</sup> ACS Reagent Chemicals, Specifications and Procedures for Reagents and Standard-Grade Reference Materials, American Chemical Society, Washington, DC. For suggestions on the testing of reagents not listed by the American Chemical Society, see Analar Standards for Laboratory Chemicals, BDH Ltd., Poole, Dorset, U.K., and the United States Pharmacopeia and National Formulary, U.S. Pharmacopeial Convention, Inc. (USPC), Rockville, MD.



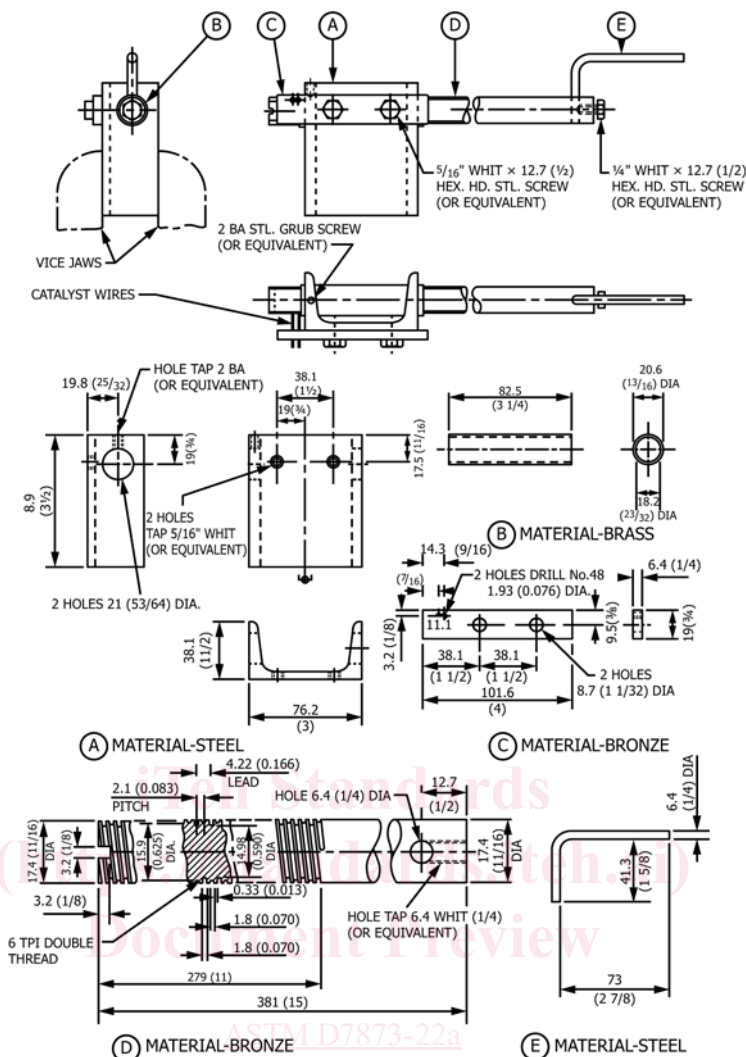

FIG. 4 Mandrel for Winding Catalyst Coils

logarithmic interpolation. Therefore, approximately 2200 mL to 2900 mL will be required for this test.

## 9. Preparation of Apparatus

**9.1 Cleaning Catalyst**—Immediately prior to winding a catalyst coil, clean a 3.00 m ± 0.01 m length of iron wire and an equal length of copper wire with wads of absorbent cotton wet with *n*-heptane and follow by abrasion with abrasive cloth until a fresh metal surface is exposed. Then wipe with dry absorbent cotton until all loose particles of metal and abrasive have been removed. In subsequent operations, handle the catalyst wires with clean gloves (cotton, rubber, or plastic) to prevent contact with the skin.

**9.2 Preparation of Catalyst Coil**—Twist the iron and copper wires tightly together at one end for three turns and then wind them simultaneously alongside each other on a threaded mandrel (see Fig. 4), inserting the iron wire in the deeper thread. Remove the coil from the mandrel, twist the free ends of the iron and copper wires together for three turns, and bend the twisted ends to conform to the shape of the spiral coil. The

overall length of the finished coil should be 225 mm ± 5 mm (8.9 in. ± 0.2 in.). If necessary, the coil may be stretched to give the required length (Note 4).

NOTE 4—The finished catalyst coil is a double spiral of copper and iron wire, 225 mm ± 5 mm (8.9 in. ± 0.2 in.) overall length and 15.9 mm to 16.5 mm (0.625 in. to 0.650 in.) inside diameter. The turns of wire are evenly spaced, and two consecutive turns of the same wire are 3.96 mm to 4.22 mm (0.156 in. to 0.166 in.) apart, center to center. The mandrel shown in Fig. 4 is designed to produce such a coil. Using this mandrel, the iron wire is wound on a thread of 14.98 mm (0.590 in.) diameter, while the copper wire is wound on a thread of 15.9 mm (0.625 in.) diameter. The smaller diameter is to allow for “springback” of the steel wire after winding, so as to give 15.9 mm consistent inside diameter. Use of a very soft annealed steel wire may allow use of identical thread diameters for the two wires. Any arrangement that leads to the coil configuration described above is satisfactory.

**9.3 Catalyst Storage**—The catalyst coil may be stored in a dry, inert atmosphere prior to use. A suitable procedure for catalyst storage is given in Appendix X1. Before use, it should be inspected to ensure that no corrosion products or contaminating materials are present. For overnight storage (less than 24 h) the coil may be stored in *n*-heptane.