



Designation: **D8003–15a (Reapproved 2021) D8003 – 22**

## Standard Test Method for Determination of Light Hydrocarbons and Cut Point Intervals in Live Crude Oils and Condensates by Gas Chromatography<sup>1</sup>

This standard is issued under the fixed designation D8003; the number immediately following the designation indicates the year of original adoption or, in the case of revision, the year of last revision. A number in parentheses indicates the year of last reapproval. A superscript epsilon ( $\epsilon$ ) indicates an editorial change since the last revision or reapproval.

### 1. Scope Scope\*

1.1 This test method covers the determination of light hydrocarbons and cut point intervals by gas chromatography in live crude oils and condensates with VPCR<sub>4</sub> (see **Note 1**) up to 500 kPa at 37.8 °C.

NOTE 1—As described in Test Method **D6377**.

1.2 Methane (C<sub>1</sub>) to hexane (nC<sub>6</sub>) and benzene are speciated and quantitated. Samples containing mass fractions of up to 0.5 % methane, 2.0 % ethane, 10 % propane, or 15 % isobutane may be analyzed. A mass fraction with a lower limit of 0.001 % exists for these compounds.

1.3 This test method may be used for the determination of cut point carbon fraction intervals (see **3.1-3.2.1**) of live crude oils and condensates from initial boiling point (IBP) to 391 °C (nC<sub>24</sub>). The nC<sub>24</sub> plus fraction is reported.

1.4 Dead oils or condensates sampled in accordance with **12.1** may also be analyzed.

1.5 The values stated in SI units are to be regarded as standard. No other units of measurement are included in this standard.

1.5.1 *Exception*—Where there is no direct SI equivalent such as tubing size.

1.6 *This standard does not purport to address all of the safety concerns, if any, associated with its use. It is the responsibility of the user of this standard to establish appropriate safety, health, and environmental practices and determine the applicability of regulatory limitations prior to use.*

1.7 *This international standard was developed in accordance with internationally recognized principles on standardization established in the Decision on Principles for the Development of International Standards, Guides and Recommendations issued by the World Trade Organization Technical Barriers to Trade (TBT) Committee.*

### 2. Referenced Documents

2.1 *ASTM Standards*:<sup>2</sup>

<sup>1</sup> This test method is under the jurisdiction of ASTM Committee **D02** on Petroleum Products, Liquid Fuels, and Lubricants and is the direct responsibility of Subcommittee **D02.04.0L** on Gas Chromatography Methods.

Current edition approved ~~Jan. 1, 2021~~ Nov. 1, 2022. Published ~~February 2021~~ November 2022. Originally approved in 2015. Last previous edition approved in ~~2015~~ 2021 as ~~D8003–15a~~ D8003 – 15a (2021). DOI: ~~10.1520/D8003-15AR21~~ 10.1520/D8003-22.

<sup>2</sup> For referenced ASTM standards, visit the ASTM website, www.astm.org, or contact ASTM Customer Service at service@astm.org. For *Annual Book of ASTM Standards* volume information, refer to the standard's Document Summary page on the ASTM website.

\*A Summary of Changes section appears at the end of this standard

[D1265 Practice for Sampling Liquefied Petroleum \(LP\) Gases, Manual Method](#)  
[D3700 Practice for Obtaining LPG Samples Using a Floating Piston Cylinder](#)  
[D4175 Terminology Relating to Petroleum Products, Liquid Fuels, and Lubricants](#)  
[D4307 Practice for Preparation of Liquid Blends for Use as Analytical Standards](#)  
[D5002 Test Method for Density, Relative Density, and API Gravity of Crude Oils by Digital Density Analyzer](#)  
[D6299 Practice for Applying Statistical Quality Assurance and Control Charting Techniques to Evaluate Analytical Measurement System Performance](#)  
[D6377 Test Method for Determination of Vapor Pressure of Crude Oil: VPCR<sub>x</sub> \(Expansion Method\)](#)  
[D6792 Practice for Quality Management Systems in Petroleum Products, Liquid Fuels, and Lubricants Testing Laboratories](#)  
[E1510 Practice for Installing Fused Silica Open Tubular Capillary Columns in Gas Chromatographs](#)

### 2.2 Other Regulations:

[CAN/CGSB-3.0 No. 14.3-99 Standard Test Method for the Identification of Hydrocarbon Components in Automotive Gasoline using Gas Chromatography](#)<sup>3</sup>

## 3. Terminology

### 3.1 Definitions:

3.1.1 For definitions of terms used in this test method, refer to Terminology [D4175](#).

#### 3.2 ~~Definitions:~~ *Definitions of Terms Specific to This Standard:*

3.2.1 *cut point carbon fraction interval, n*—the percent mass obtained between two selected n-paraffins of the interval. The cut point carbon fraction interval as used in this test method is defined as the percent mass obtained between the end of one n-paraffin peak to the end of the next n-paraffin peak, thus a temperature interval is not used to determine the cut points but rather the end points sequential of a n-paraffin peak pair.

3.2.2 *D1265 cylinder, n*—a container used for storage and transportation of a sample obtained at pressures above atmospheric pressure as described in Practice [D1265](#).

3.2.3 *dead crude oil, n*—a term usually employed for crude oils that, when exposed to normal atmospheric pressure at room temperature, will not result in actual boiling of the sample.

#### 3.2.3.1 Discussion—

These crudes will have vapor pressures below atmospheric pressure at room temperature.

3.2.4 *floating piston cylinder, n*—a high pressure sample container, with a free floating internal piston that effectively divides the container into two separate compartments, as described in Practice [D3700](#).

3.2.5 *live crude oil, n*—crude oil with sufficiently high vapor pressure that it would boil if exposed to normal atmospheric pressure at room temperature.

#### 3.2.5.1 Discussion—

Sampling and handling of live crude oils requires a pressurized sample system and pressurized sample containers to ensure sample integrity and prevent loss of volatile components.

3.2.6 *residue, n*—the percent mass of the sample that either does not elute from the column or elutes after the end of the nC<sub>24</sub> peak.

3.2.7 *vapor pressure of crude oil (VPCR<sub>x</sub>), n*—the pressure exerted in an evacuated chamber at a vapor-liquid ratio of X:1 by conditioned or unconditioned crude oil, which may contain gas, air, or water, or a combination thereof, where X may vary from 4 to 0.02.

## 4. Summary of Test Method

4.1 This is a gas chromatographic method using a Heated Pressurized Liquid Injection System (HPLIS) (trademarked)<sup>4</sup>, split/splitless inlet, capillary column, and flame ionization detector. A calibration mixture which fully elutes from the capillary

<sup>3</sup> Available from Standards Council of Canada (SCC), 600–55 Metcalfe St., Ottawa, ON K1P 6L5, <http://www.scc.ca>.

<sup>4</sup> HPLIS (trademarked) has been found to be a suitable injector. The sole source of supply of the HPLIS known to the committee at this time is Transcendent Enterprises Inc., #33: 17715 - 96 Ave Edmonton, Alberta, Canada, T5T 6W9, [www.transcendent.ca](http://www.transcendent.ca). If you are aware of alternative suppliers, please provide this information to ASTM International Headquarters. Your comments will receive careful consideration at a meeting of the responsible technical committee,<sup>1</sup> which you may attend.

column, consisting of a full range of hydrocarbons including methane, ethane, and normal paraffins up to C<sub>24</sub> is used to ensure system performance (Section 7). This calibration mixture serves as an external response standard to determine sample recovery. Samples are introduced to the GC system by loading the HPLIS valve under pressure followed by the pneumatic piston action of the HPLIS injection system introducing the sample into the gas chromatographic injection port.

## 5. Significance and Use

5.1 This test method determines methane (nC<sub>1</sub>) to hexane (nC<sub>6</sub>), cut point carbon fraction intervals to nC<sub>24</sub> and recovery (nC<sub>24+</sub>) of live crude oils and condensates without depressurizing, thereby avoiding the loss of highly volatile components and maintaining sample integrity. This test method provides a highly resolved light end profile which can aid in determining and improving appropriate safety measures and product custody transport procedures. Decisions in regards to marketing, scheduling, and processing of crude oils may rely on light end compositional results.

5.2 Equation of state calculations can be applied to variables provided by this method to allow for additional sample characterization.

## 6. Apparatus

6.1 *Gas Chromatograph*—The recommended conditions of the gas chromatograph are listed in Table 1. The gas chromatograph shall be equipped with an electronic pressure control (EPC) or manual split/splitless inlet system. A 4-way 24 VDC solenoid valve controlled from the gas chromatograph keyboard for actuator air pressure control to accommodate the HPLIS is also required. Important features of instrument components are listed in section 6.2 to 6.4.

6.2 *Data System*—A data system capable of measuring the retention time and areas of eluting peaks accurately and repeatedly as well as possess a data rate to achieve 10 points to 20 points per peak.

6.3 *Flame Ionization Detector (FID)*—A FID system shall be connected to the column to avoid any cold spots and have the ability to operate at a temperature equivalent to the maximum column temperature used. The detector shall have sufficient sensitivity to detect n-heptane at a mass fraction of 0.01 % with a signal-to-noise greater than 5.

6.4 *Heated Pressure Liquid Injection System (HPLIS)*—A HPLIS system that is compatible with a split/splitless inlet and capable of linearly introducing C<sub>1</sub> to C<sub>24</sub> components should be used. The unit should possess an internal dead volume of ≤80 μL in sample

**TABLE 1 Gas Chromatograph Parameters**

Initial Oven Temperature	35 °C
Initial Oven Time	2 min
Oven Temperature Program	20 °C/min
Final Oven Temperature	310 °C
Final Hold Time	10 min
HPLIS Collar Heater Temperature	200 °C
Inlet Temperature	400 °C
Column	15 m × 0.28 mm × 3 μm PDMS
Column Flow (Hydrogen)	2 mL/min
Carrier Control	Constant Flow
Detector	FID
Detector Temperature	425 °C
Detector Gases:	
Hydrogen	40 mL/min
Air	450 mL/min
Make-Up (N <sub>2</sub> )	25 mL/min
Volume Injected	0.5 μL
Split Ratio	30:1
Data Acquisition Rate	10 Hz
HPLIS Valve Timing On	0 min
HPLIS Valve Timing Off	0.3 min
Total Acquisition Time	25.75 min

transfer zone and a 0.5 uL stem volume to contain the pressurized liquid sample. The sample pressure rating for the unit should be  $\geq 8300$  kPa (1200 psig) at 30 °C using helium as the test media. Other injection systems may be employed provided the performance criteria in Section 7 are met.

### 7. Column and Performance Criteria

7.1 A 100 % polydimethylsiloxane (PDMS) phase column of a 15 m length with an inside diameter of 0.28 mm and 3  $\mu$ m film thickness is recommended. The column shall possess stability at 380 °C. Metal columns have been successfully used for this test method. The column should be installed according to Practice E1510. To prevent column overloading, the skewness is measured for nC<sub>6</sub>. The value shall not be less than 1 or more than 4. Skewness is determined drawing a straight line down the apex, as well as one across the length of the nC<sub>6</sub> peak at 5 % height. The width of the right section of the peak at 5 % height (B) is divided by that of the left section (A) (see Fig. 1).

7.2 Baseline resolution for C<sub>1</sub>, C<sub>2</sub>, C<sub>3</sub>, isobutane and butane shall be achieved ( $R \geq 1.0$ ). The resolution is calculated as follows:

$$R = 2 \times (t_2 - t_1) / 1.699(w_1 + w_2) \tag{1}$$

where:

- t<sub>2</sub> = retention time of peak 1,
- t<sub>1</sub> = retention time of peak 2,
- w<sub>1</sub> = peak width at half height for peak 1, and
- w<sub>2</sub> = peak width at half height for peak 2.

7.3 *Splitter Linearity Verification*—Using the calibration standard (see 8.1.4), inject this sample according to the parameters listed in Table 1. Identify and quantify the normal paraffins C<sub>1</sub> to C<sub>24</sub>. Compare the calculated mass %percent concentrations to the known standard concentrations after calculating the corrected area normalization using the response factors from Table 2 procedures in Section 13. Verify that for each component selected, its concentration does not vary by more than 3 % relative error.

$$\text{percent relative error} = 100 \times \frac{(\text{concentration determined} - \text{concentration known})}{\text{concentration known}} \tag{2}$$

7.4 The sensitivity of the system shall be determined by analyzing a 10 mg/kg pentane standard (Practice D4307). The signal to noise ratio shall be greater than 5.

### 8. Reagents and Materials

8.1 *Gas Chromatograph Gases*—The purity of the volume fraction for all gases used in this system should be  $\geq 99.995$  %.

8.1.1 *Carrier Gas*—Hydrogen. Follow proper safety procedures. (**Warning**—Extremely flammable under high pressure; use of a safety hydrogen sensor in GC oven containing the column is highly recommended.)

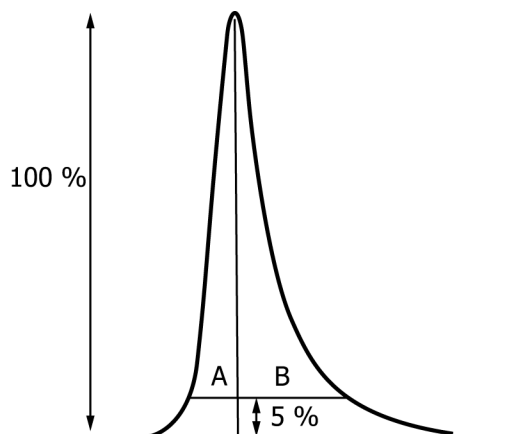

FIG. 1 Calculation of Peak Skewness

**TABLE 2 Component Properties and Theoretical Response Factors<sup>A</sup>**

Component	Molecular Weight of Compound (g/mol)	Density of Compound @ 20 °C (g/mL)	Generalized Boiling Point of Cut Point Fraction Interval °C	Generalized Molecular Weight of Cut Point Fraction Interval (g/mol)	Generalized Density of Cut Point Fraction Interval @ 20 °C (g/mL)	Theoretical Mass Response Factor
C <sub>1</sub>	16.04	0.26				1.00
C <sub>2</sub>	30.08	0.34				0.937
C <sub>3</sub>	44.10	0.505				0.916
iC <sub>4</sub>	58.12	0.557				0.906
n-C <sub>4</sub>	58.12	0.5788				0.906
iC <sub>5</sub>	72.15	0.6201				0.899
n-C <sub>5</sub>	72.15	0.6262				0.899
n-C <sub>6</sub>	86.18	0.6603	63.9	84	0.685	0.895
Benzene	78.12	0.8765				0.812
n-C <sub>7</sub>	100.21	0.6837	91.9	96	0.722	0.892
n-C <sub>8</sub>	114.22	0.7025	116.7	107	0.745	0.890
n-C <sub>9</sub>	128.26	0.7176	142.2	121	0.764	0.888
n-C <sub>10</sub>	142.28	0.73	165.8	134	0.778	0.887
n-C <sub>11</sub>	156.32	0.7402	187.2	147	0.789	0.886
n-C <sub>12</sub>	170.34	0.7487	208.3	161	0.800	0.885
n-C <sub>13</sub>	184.37	0.7564	227.2	175	0.811	0.884
n-C <sub>14</sub>	198.39	0.7628	246.4	190	0.822	0.883
n-C <sub>15</sub>	212.41	0.7685	266	206	0.832	0.883
n-C <sub>16</sub>	226.45	0.7733	283	222	0.839	0.882
n-C <sub>17</sub>	240.48	0.778	300	237	0.847	0.882
n-C <sub>18</sub>	254.51	0.782	313	251	0.852	0.881
n-C <sub>19</sub>	268.53	0.7855	325	263	0.857	0.881
n-C <sub>20</sub>	282.56	0.7886	338	275	0.862	0.881
n-C <sub>21</sub>	296.59	0.7919	351	291	0.867	0.880
n-C <sub>22</sub>	310.61	0.7944	363	305	0.872	0.880
n-C <sub>23</sub>	324.67	0.7969	375	318	0.877	0.880
n-C <sub>24</sub>	338.67	0.7991	386	331	0.881	0.880
Residue			540	500	0.925	0.88

<sup>A</sup> Density and molecular weight values for C<sub>1</sub> to benzene obtained from *CRC Handbook of Chemistry and Physics*, 61st ed, CRC Press, Boca Raton, FL, 1981. Theoretical Mass response factors up to nC<sub>15</sub> obtained from Test Method: CAN/CGSB-3.0 No. 14.3-99.

Generalized component properties of boiling point, molecular weight and density are averages and best estimates obtained from Katz, D. L., Firoozabadi, A., "Predicting Phase Behavior of Condensate/Crude-Oil Systems Using Methane Interaction Coefficients, Society of Petroleum Engineers," (SPE 6721), 1978.

Residue properties are estimates only and will vary for sample type.

## Document Preview

**8.1.2 Detector Gases**—Air, hydrogen, and make-up gas (helium or nitrogen) are used for Flame Ionization Detector operation (**Warning**—Compressed gas under high pressure. Hydrogen is extremely flammable under high pressure.)

**8.1.3 Injection System Wash**—Methylene chloride, with a purity of 99 %, used to remove any residual components from HPLIS sample injection. (**Warning**—Toxic material. May be combustible at high temperatures.) Toluene, with a purity of 99 %, or other suitable solvents may be used as an alternative to methylene chloride but caution shall be taken to eliminate residual sample and solvent in the HPLIS sample lines.

**8.1.4 Calibration Standard**—The calibration standard may serve three purposes. A retention time calibration for n-paraffins covering the range of C<sub>1</sub> to nC<sub>24</sub>, the determination of the detector response to enable the sample recovery calculation and a linearity check sample. A hydrocarbon mixture such as a gasoline mid-distillate (diesel or jet fuel) containing a known amount of C<sub>1</sub>, C<sub>2</sub>, C<sub>3</sub>, nC<sub>5</sub>, and n-paraffins in the range of nC<sub>17</sub> through nC<sub>24</sub> is required. All n-paraffins present up to nC<sub>24</sub> shall be identifiable. The calibration standard shall completely elute from the column by peak end of nC<sub>24</sub> under the conditions of the method. A commercially prepared calibration standard or one prepared as described in the Appendix of this method has been found to be successful.

## 9. Preparation of Apparatus

**9.1** Install the HPLIS system according to supplier procedures. The unit should have one of the sample chamber tubes connected to an isolation (needle) valve to allow control and termination of sample flow during the 'inject' cycle. Attach 1/16 in. SS tubing to the remaining sample chamber tube. This will be attached to the sample cylinder. Install the appropriate column and check for leaks. Set the gas chromatograph to the conditions stated in **Table 1**.

**9.2 Baseline**—Obtain a suitable blank baseline prior to any analysis or after any system change (**Fig. A1.2**). A blank run requires actuation of the HPLIS without a sample injection. It may take several blanks to show a stable plateau at the highest temperature of the oven with no indication of residual elution or of carryover. It should also not contain any 'ghost' peaks. Overlay the baseline

signal with the sample signal as shown in **Fig. A1.2**. Use only those sample signals that asymptotically approach the baseline signals. Reject any sample run where the baseline signal at the end of the run exceeds in value the sample run.

## 10. Calibration

10.1 Calibration and performance criteria (Section 7) shall be performed whenever HPLIS valve or gas chromatograph maintenance is performed.

10.1.1 HPLIS valve maintenance includes seal replacement.

10.1.2 Gas chromatograph maintenance includes column replacement, injection port or detector cleaning.

10.1.3 Calibration shall include verification of total area reproducibility. The calibration standard (8.1.4) shall be run at a minimum interval of every five samples. All sample runs shall be bracketed by a preceding and following calibration standard run. The total area of the calibration runs shall not vary more than  $\pm 3\%$  absolute from run to run. If it does not meet this requirement ensure all hardware is operating properly and all instrument settings are as stated above or recommended by the manufacturer.

10.1.4 Apply statistical quality control techniques (Practice D6299) to the area percent of the calibration standard peaks  $C_1$ ,  $C_2$ ,  $C_3$ ,  $iC_4$ ,  $C_4$ ,  $nC_{20}$ ,  $nC_{21}$ ,  $nC_{22}$ ,  $nC_{23}$ , and  $nC_{24}$  to monitor split linearity (see 7.3).

## 11. Quality Control

11.1 *Quality Control (QC) Testing*—Conduct a regular statistical quality assurance (quality control) program in accordance with Practice D6792 and the techniques of Practice D6299 or equivalent.

11.2 This test method requires quality control testing at the beginning of each operating period using a single determination. An interval of once per week or after every 10 samples is recommended.

11.3 The QC sample is a live crude oil containing light ends ( $C_1$  to  $C_6$ ) in concentrations typical to those of analytical samples. The QC sample should be contained in cylinders described in section 12.1. Store the QC sample under pressure and temperature conditions that maintain a single liquid phase.

11.4 Results from the analysis of the quality control sample shall be in statistical control in accordance with Practice D6299, or other equivalent practice. Otherwise, if agreement with the expected value is not attained, corrective action shall be taken, verified by successful analysis of the quality control sample.

## 12. Procedure

12.1 Samples should be collected with the utmost care to maintain a single liquid phase and to eliminate losses through evaporation with resulting changes in composition. Collect samples in a floating piston cylinder or similar high pressure sample cylinder adhering to principles of Practice D3700 or D1265. Follow manufacturer or site specific protocols. A floating piston cylinder is represented in **Fig. 2**. Refer to section 12.2 if using a floating piston cylinder. If a D1265 cylinder is being used refer to 12.3.

12.2 *Floating Piston Cylinder Procedure*—Connect the floating piston cylinder to the pre-charge gas tank equipped with a pressure regulator to that of the closed pre-charge valve of the floating piston cylinder. Connect  $\frac{1}{16}$  in. tubing from the sample chamber of the HPLIS to the product inlet valve of the floating piston cylinder. **Fig. 3A** represents the completed set-up.

12.2.1 Charge the floating piston cylinder with  $2000 \text{ kPa} \pm 175 \text{ kPa}$  of pressure with the precharge valve open.

12.2.2 The pre-charge gas should be an inert gas such as helium, nitrogen, or argon. The use of air is not recommended. Oxygen shall not be used. The pre-charge gas is one that is not normally present in the sample or one that will not be detected should it leak into the sample. The measurement of dissolved nitrogen ( $N_2$ ) and carbon dioxide ( $CO_2$ ) by a different or adjunct method may be of interest. The use of these gases may impact the subsequent gas analysis. Place the GC system in a ready for injection state. Ensure the HPLIS is in the load position (deactivated). Ensure the isolation (needle) valve is closed and the vent/vacuum valve is in the Vent position (**Fig. 3B**). Slowly open the product inlet.



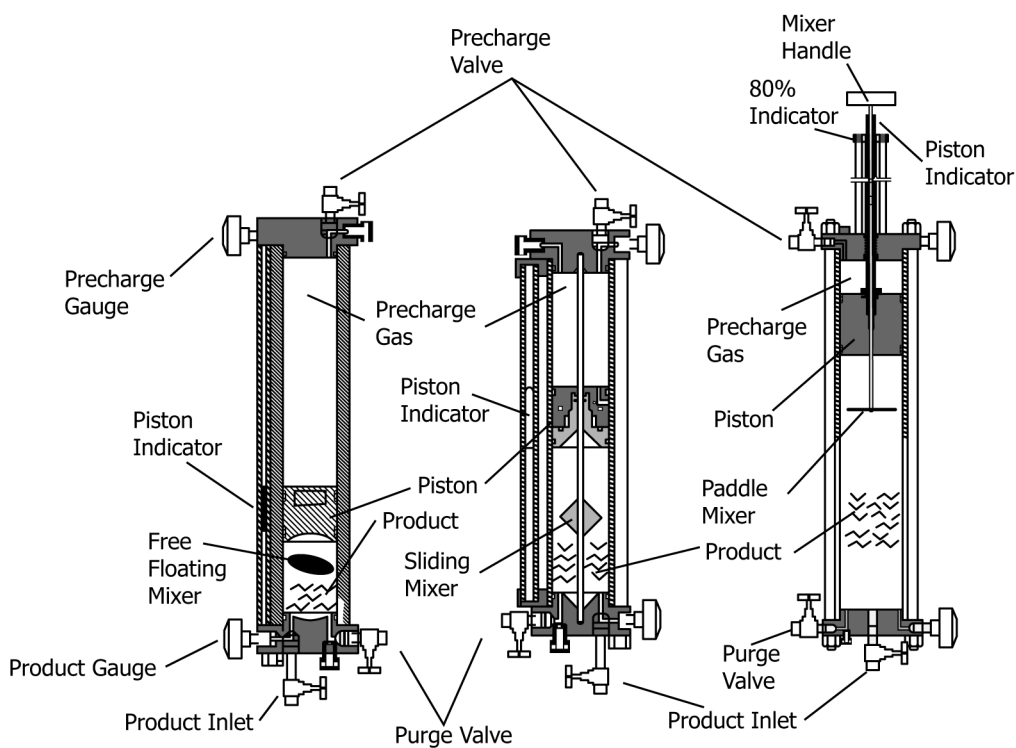

iTeh Standards  
 (https://standards.itih.ai)  
 Document Preview

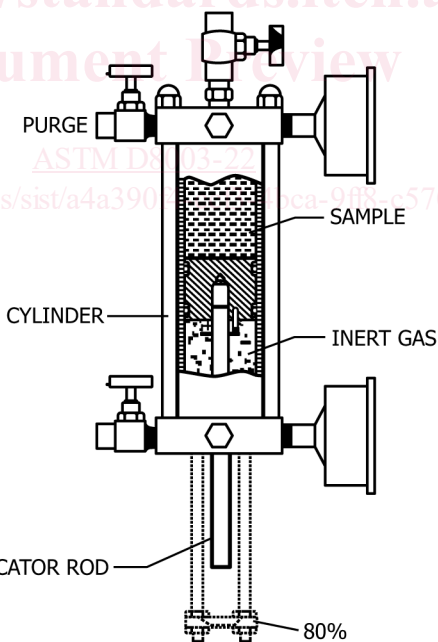

NOTE 1—Image from Practice D3700.

FIG. 2 Typical Floating Piston Cylinder Designs with Valving

12.2.3 Open and close the isolation (needle) valve six times (Fig. 3C) then initiate the run using the GC software (Fig. 3D). Close the product inlet valve and shut off the pressure of the pre-charge gas. Turn on a vacuum pump (30 mm ± 5 mm Hg) and switch the vent/vacuum valve to the vacuum position. Open the isolation (needle) valve. Allow the sample chamber to evacuate for at least one minute. Remove the sample cylinder from the sample chamber connection. Flush the sample lines with a suitable solvent to