



Designation: F1828 – 22

Standard Specification for Ureteral Stents¹

This standard is issued under the fixed designation F1828; the number immediately following the designation indicates the year of original adoption or, in the case of revision, the year of last revision. A number in parentheses indicates the year of last reapproval. A superscript epsilon (ϵ) indicates an editorial change since the last revision or reapproval.

INTRODUCTION

The objective of this specification is to describe the test methods used to evaluate the safety and effectiveness of an indwelling ureteral stent, having retention means at the kidney and bladder ends, used for urinary drainage of the kidney to the bladder via the ureter.

This specification includes referee test methods that can be used to evaluate the performance characteristics of ureteral stents. Note that the test methods are not to be construed as production methods, quality control techniques, or manufacturer's lot release criteria. The product parameters addressed by the standard include those determined by the ASTM task group to be pertinent to the product.

1. Scope

1.1 This specification covers the referee test methods for evaluating the performance characteristics of a single-use ureteral stent with retaining means at both ends, during short-term use for drainage of urine from the kidney to the bladder. These stents are typically available in diameters of 3.7 Fr to 14.0 Fr, and lengths of 8 cm to 30 cm, and are made of silicone, polyurethane, and other polymers. They are provided non-sterile for sterilization and sterile for single use.

1.2 *Exclusions*—Long-term indwelling usage (over 30 days) is encountered with this product, but not commonly, and is therefore considered an exception to this specification. Similarly, the use of ureteral stents for non-ureteral applications such as nephrostomy and ileostomy is excluded from the scope of this specification. Non-sterile ureteral stents are also excluded due to the variability of hospital sterilization equipment and processes and the resulting effects on ureteral stent characteristics.

1.3 The following precautionary statement pertains only to the test method portion, Section 5, of this specification:

1.4 *This standard does not purport to address all of the safety concerns, if any, associated with its use. It is the responsibility of the user of this standard to establish appropriate safety, health, and environmental practices and determine the applicability of regulatory limitations prior to use.*

¹ This specification is under the jurisdiction of ASTM Committee F04 on Medical and Surgical Materials and Devices and is the direct responsibility of Subcommittee F04.34 on Urological Materials and Devices.

Current edition approved Nov. 1, 2022. Published November 2022. Originally approved in 1997. Last previous edition approved in 2017 as F1828 – 17. DOI: 10.1520/F1828-22.

1.5 *This international standard was developed in accordance with internationally recognized principles on standardization established in the Decision on Principles for the Development of International Standards, Guides and Recommendations issued by the World Trade Organization Technical Barriers to Trade (TBT) Committee.*

2. Referenced Documents

2.1 *ASTM Standards:*²

D412 Test Methods for Vulcanized Rubber and Thermoplastic Elastomers—Tension

F640 Test Methods for Determining Radiopacity for Medical Use

F748 Practice for Selecting Generic Biological Test Methods for Materials and Devices

3. Terminology

3.1 *Definitions of Terms Specific to This Standard:*

3.1.1 *test media*—(1) saline, an isotonic solution of pH 5.5 to 7.0; (2) human urine; or (3) artificial urine, a solution of organic and inorganic compounds that closely simulates the chemical and physical properties of normal human urine. Artificial urine may be used as a substitute for human urine to simulate the effects of human urine on ureteral stents.

3.1.2 *bladder retention means*—physical feature of bladder end of stent that prevents movement of stent out of bladder.

3.1.3 *break strength*—peak tensile load required to break stent.

² For referenced ASTM standards, visit the ASTM website, www.astm.org, or contact ASTM Customer Service at service@astm.org. For *Annual Book of ASTM Standards* volume information, refer to the standard's Document Summary page on the ASTM website.

3.1.4 *cross section*—view of stent tube when cut in a plane perpendicular to length of stent.

3.1.5 *distal*—situated away from the point of origin. The distal end of a stent is the end that resides in the bladder, also known as the bladder end.

3.1.6 *drainage holes*—holes in wall of stent tubing that allow flow of urine into and out of lumen of stent.

3.1.7 *dynamic frictional force*—resistance to relative motion between two surfaces during motion. This force is defined as the coefficient of kinetic friction multiplied by the force acting on the surface of the material in a plane perpendicular to the surface.

3.1.8 *elongation*—expressed as a percent, is equal to the change in length of a sample of tubing at failure divided by its original length. Stretching of the tubing is produced by tensile loading.

3.1.9 *French size*—scale used to indicate size of tubular devices, each unit being approximately equal to 0.013 in. or 0.33 mm in diameter. Typical label French sizes are as follows:

French Size	Outside Diameter in. mm
3.7	0.050, 1.23
4.5	0.060, 1.50
4.7	0.061, 1.57
6.0	0.079, 2.00
7.0	0.092, 2.33
8.0	0.105, 2.67
8.5	0.112, 2.83
10.0	0.131, 3.33
14.0	0.183, 4.66

3.1.10 *kidney retention means*—physical feature of kidney end of stent that prevents movement of stent out of the kidney.

3.1.11 *length*—distance between the most proximal portion of the bladder retention means and the most distal portion of the kidney retention means when the stent is laying on a flat surface with the main shaft straight (see Figs. 1 and 2).

3.1.12 *lumen*—channel within a tube.

3.1.13 *proximal*—situated toward the point of origin. In the urinary tract, the kidney is considered to be the point of origin. The proximal end of a stent is the end that resides in the renal pelvis, also known as the kidney end.

3.1.14 *radiopacity*—property indicating ability of device to absorb X-ray energy, allowing device to be seen in a radiograph or fluoroscopic image.

3.1.15 *referee test method*—method cited in the published specification for the device. This method will be used when the performance of the ureteral stent is to be evaluated. The manufacturer need not use this referee test method for inspection and quality control.

3.1.16 *retention strength*—force required to overcome the retaining means on a stent.

3.1.17 *sterility*—state of being free of microorganisms. For purposes of this specification, sterility is defined as freedom from microorganisms when tested according to the methodology defined by the USP for nonparenteral devices.

3.1.18 *tolerances*—allowable deviation from a standard size. The tolerance for the length of a ureteral stent is ± 0.5 cm (0.197 in.). The tolerance for the specified French size of a ureteral stent is ± 0.01 cm (0.004 in.), or approximately $\frac{1}{3}$ -French.

3.1.19 *ureteral stent*—indwelling tubular device that resides in the kidney, ureter, and bladder containing means for retaining ends of tube in kidney and bladder.

4. Requirements

4.1 *Biocompatibility*—Ureteral stents shall be tested in accordance with the appropriate biological tests contained in Practice F748 or similar guidance established by the U.S. Food and Drug Administration (FDA) or International Organization for Standardization (ISO).

5. Special Precautions

5.1 The following cautionary comments recognize the sensitivity of the materials of construction to potential environmental conditions. These are outlined here to point out potential situations that could adversely affect the performance of the stent during testing.

5.1.1 Care should be taken during testing and use to prevent damage to the stents. Such damage can be caused by abrasion and contact with sharp objects or chemical products.

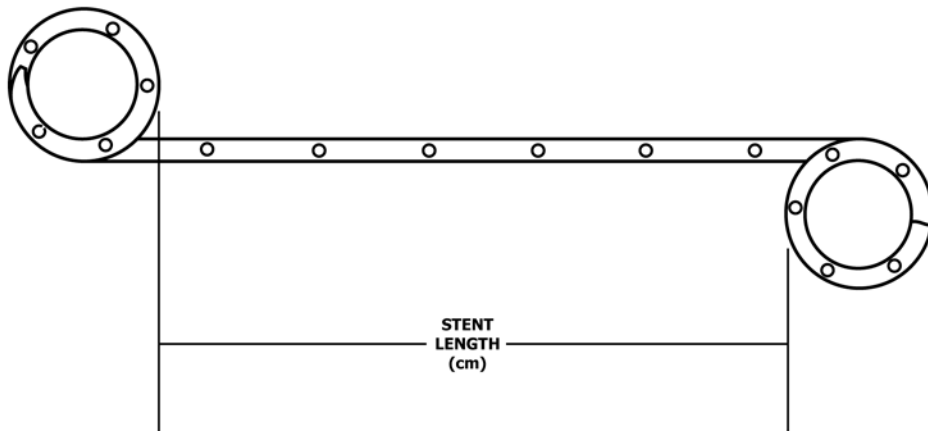

FIG. 1 Determination of Stent Length

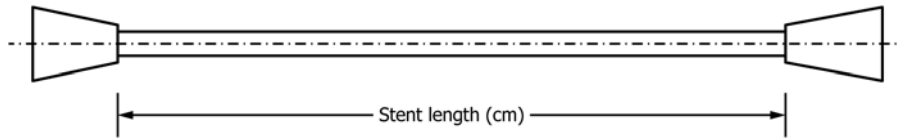

FIG. 2 Determination of Stent Length (alternative stent anchorage design)

5.1.2 Stents should be kept away from generators, electric motors, diathermy machines, and fluorescent lights because the ozone produced may attack elastomeric materials. This applies to both storage and handling.

5.1.3 To help avoid contamination of the stents, proper handling precautions should be observed.

6. Test Methods

6.1 General Guidelines:

6.1.1 Test samples should consist of actual ureteral stents, not material slabs.

6.1.2 Use statistically valid sample sizes in all tests.

6.1.3 Package all stent test samples and sterilize using the method of sterilization intended to be used for product when it is sold.

6.1.4 Expose test samples to test media at 37 ± 3 °C for an appropriate duration (for example, 30 days). When test media is artificial urine, use either of the formulations listed in Annex A1.

6.1.5 Maintain pH of test media in the range of 5.5 to 6.5 at all times. Test media should be replaced weekly.

6.1.6 Perform tests prior to and after soaking for an appropriate duration (for example, 30 days). For products with intended chemical/mechanical changes such as softening, swelling, etc., conduct initial mechanical testing only after sufficient soaking time has elapsed that allows such chemical/mechanical changes to occur.

6.1.7 Dynamic frictional force test samples need only be soaked in saline test media for 1 min prior to testing. This test need not be repeated after 30 days.

6.2 Retention Strength:

6.2.1 Scope—This test method measures the ability of a ureteral stent to resist migration. It can be used for testing the proximal or distal ends of a ureteral stent.

6.2.2 Summary of Test Method:

6.2.2.1 The apparatus is set up as shown in Fig. 3. Clearance between the outside diameter of the stent and inside diameter

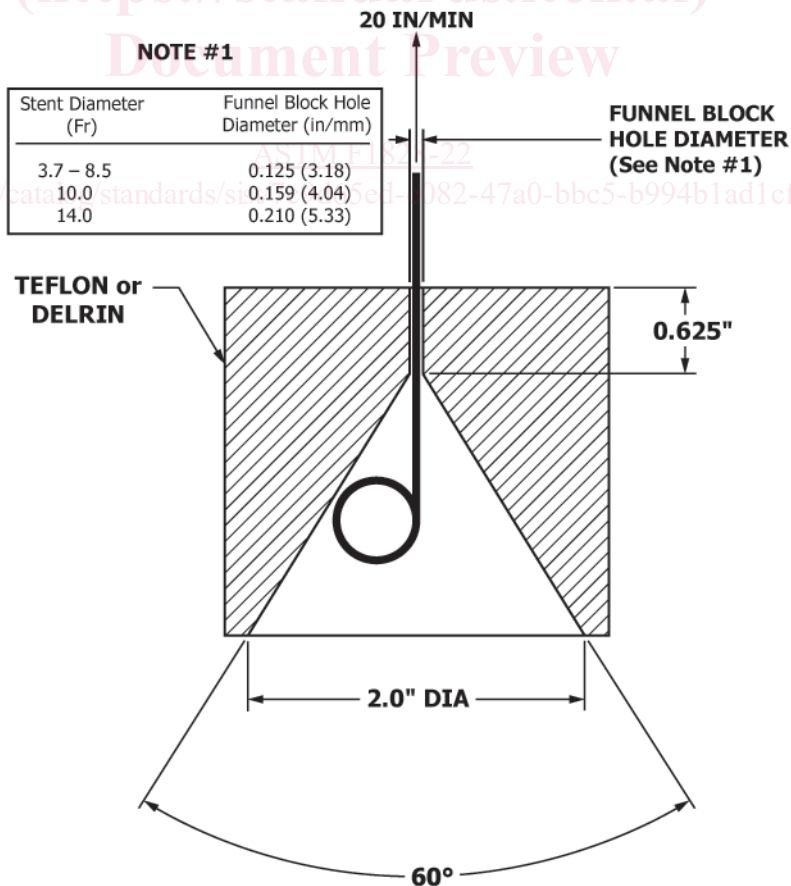

FIG. 3 Funnel Block for Retention Strength Test

of the funnel block hole must be present. (See Note #1 in Fig. 3 for a list of appropriate funnel block hole diameters to be used with stents of different French sizes.)

6.2.2.2 Maintain temperature in the saline test media at $37 \pm 3^\circ\text{C}$ by whatever means is available to the test facility. Submerge the entire funnel block. Set the pull rate through the fixture at a constant 20 in./min. Clean the test bath and fixture at the beginning of each testing day. The capacity of the load cell used with the tensile testing machine should not exceed 2 lb.

6.2.3 *Test Specimen Preparation*—The test specimen shall consist of actual sterilized product. The specimen shall be cut to allow a straight portion of the stent to be inserted upwards through the funnel fixture into the grip of the tensile test machine without loading the retention mechanism of the stent to be tested. Submerge the test specimen in the saline test media for at least 1 min to allow it to reach thermal equilibrium. If the material is significantly affected by moisture, allow the specimen to equilibrate for a minimum of 24 h.

NOTE 1—The portion of the stent held within the gripping mechanism of the tensile testing machine cannot be used for additional testing due to the potential destructive effects of the gripping mechanism.

6.2.4 *Test Procedure:*

6.2.4.1 Ensure saline test media is at proper temperature and funnel is submerged. Monitor periodically.

6.2.4.2 When testing a new ureteral stent taken out of its sterile package ($t=0$), straighten retention means with appropriate guidewire. Insert straight portion of stent through bottom of funnel and into grip. When testing at $t=30$ days, retention means is not to be straightened prior to testing.

6.2.4.3 Allow stent to reach thermal equilibrium.

6.2.4.4 Pull specimen up through funnel at 20 in./min. Record maximum force required to pull stent completely through funnel.

6.3 *Break Strength:*

6.3.1 Break strength of test stents will be determined in accordance with Test Method D412, with the following modifications:

6.3.1.1 Devices used to grip the test specimen in the tensile test machine should be chosen so that the test specimen does not break at the grip location.

6.3.1.2 Most stents contain drainage holes. Ideally, these stents should break at a drainage hole. This is how tensile failures typically occur *in vivo*. However, stents may break in locations other than drainage holes. This type of failure may be indicative of potential design or process related problems. In stents without drainage holes, this type of failure is to be expected.

6.3.1.3 Only a segment of the test stent is used for the break strength test. The grippers should be separated by 1 in. This 1 in. segment must contain at least one drainage hole (if drainage holes are present) and should contain the section of the stent with the smallest cross-sectional area or weakest point.

6.4 *Elongation*—The elongation of stent segments separated by 1 in. between the extensometer grips used to hold the

segment in the tensile test machine or two marks placed on the surface of the stent will be determined in accordance with Test Method D412.

6.5 *Dynamic Frictional Force—(Required for Support of Claims of Low Friction):*

6.5.1 *Scope*—This test method measures the dynamic frictional force acting upon the outer surface of ureteral stent during placement through a small orifice. This test method is intended to simulate passage of a 6 Fr ureteral stent through an endoscope.

6.5.2 *Summary of Test Method*—Straighten the test stent using a wire mandrel and hydrate in a cylinder of saline test media. Then place it completely through the appropriate size grommet and into a water column. The mandrel is connected to a load cell that is pulled at constant rate of 20 in./min. Record the force values measured by the load cell and average to determine the dynamic frictional force.

6.5.3 *Test Setup*—(See Fig. 4.)

6.5.3.1 *Cylinder*, capable of hydrating the full length of the ureteral stent sample.

6.5.3.2 *Water Column*, used to hydrate the full length of the test stent prior to passage through grommet.

6.5.3.3 *Saline Test Media*, used to hydrate the test stent (and activate any hydrophilic coating present) at room temperature.

6.5.3.4 *Grommet*— 0.040 ± 0.002 in. thick, $\frac{5}{8}$ in. diameter disc, with a 0.079 ± 0.002 in. diameter hole in the center. The grommet is to be made of 55 Shore A Durometer silicone.

6.5.3.5 *Grommet Fixture*—The grommet is held in place by two aluminum plates containing relief holes approximately $\frac{1}{8}$ in. larger in diameter than the hole in the grommet. When mounted, the hole in the grommet should be centered about the relief hole in the aluminum plates.

6.5.3.6 *Load Cell*—Load cell capacity should not exceed 1 lb, and should be capable of measuring the frictional force within $\pm 5\%$ of its value.

6.5.3.7 *Linear Table*, used to pull the load cell at a constant rate. A linear table will not be necessary if a standard tensile test machine is used.

6.5.3.8 *Mandrel*, large enough to straighten and hold the test stent during the test. An eyelet is used on one end to attach to the load cell.

6.5.4 *Precautions:*

6.5.4.1 Follow all proper safety precautions.

6.5.4.2 Take care prior to and during testing not to cause damage to the test stent or grommet. Avoid contact with sharp or abrasive objects and any solvents that may damage the materials.

6.5.4.3 Use fresh saline test media to limit the accumulation of bacteria and presence of any leached chemicals.

6.5.5 *Test Specimen*—The test specimen should consist of the manufacturer's new, finished, packaged, and sterilized untested product *without* drainage holes, if possible.

6.5.6 *Procedure:*

6.5.6.1 Inspect grommet for proper size and integrity (no splits) prior to testing.

6.5.6.2 Using calipers (or other suitable measuring apparatus), measure diameter of stent sample near each end and in center of sample.

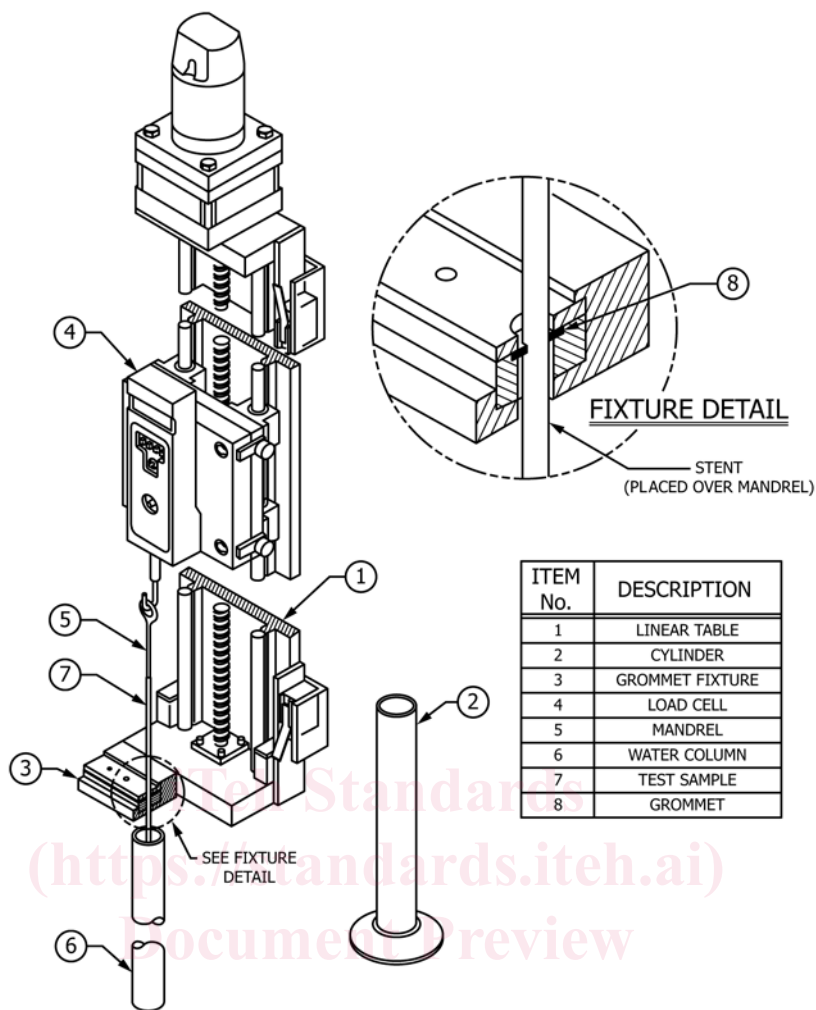

FIG. 4 Test Apparatus for Dynamic Frictional Force Test

6.5.6.3 Fill cylinder and water column with saline test media.

6.5.6.4 Load the stent sample on the mandrel on the distal end first and place in the cylinder to hydrate for a minimum of 1 min. Record hydration time.

6.5.6.5 Place the mandrel with the test sample down through the top of the grommet and into the water column.

6.5.6.6 Return the linear table or crosshead to the starting position and attach the mandrel to the load cell.

NOTE 2—The proximal (kidney) end of the stent sample must be partially through the grommet so that the initial static force does not exceed the load cell range.

6.5.6.7 Zero the load cell and data collection device.

6.5.6.8 Initiate movement of the linear table or crosshead. Stop movement once the sample has passed completely through the grommet.

6.5.6.9 Remove the test sample and mandrel from the load cell.

6.5.7 Interpretation of Results:

6.5.7.1 The average value of the collected data should be calculated. This value (in grams) represents the average dynamic frictional force between the test stent material and the silicone grommet.

6.5.7.2 If a computer is used to collect data, a minimum of 100 data points should be obtained per sample.

6.5.7.3 Calculate the average value of the stent sample diameter.

6.6 Radiopacity—Determine radiopacity of test stents in accordance with Test Method F640. Actual stents will be used as the specimens required by Test Method F640.

7. Report

7.1 Report the following information:

- 7.1.1 Average diameter and material of stent tested,
- 7.1.2 Number of stents tested,
- 7.1.3 Method used to sterilize stents,
- 7.1.4 Length of initial exposure to test media, and
- 7.1.5 Test media used (that is, saline, artificial urine, or human urine). If artificial urine is used, report should include the artificial urine formulation (see Annex A1). If human urine is used, report should include urinalysis results to characterize test media (see Annex A2). Deviations from normal concentration ranges of urine components must be included in the report.

7.1.6 Retention Strength:

- 7.1.6.1 Diameter of funnel block hole used,