



Designation: D7255 – 22<sup>ε</sup><sup>1</sup>

# Standard Test Method for Abrasion Resistance of Leather (Rotary Platform, Abraser Method)<sup>1</sup>

This standard is issued under the fixed designation D7255; the number immediately following the designation indicates the year of original adoption or, in the case of revision, the year of last revision. A number in parentheses indicates the year of last reapproval. A superscript epsilon ( $\epsilon$ ) indicates an editorial change since the last revision or reapproval.

<sup>ε</sup><sup>1</sup> NOTE—Figure X2.1, Visual Grading Scale, was updated editorially to show better contrast in November 2022.

## 1. Scope\*

1.1 This test method covers the determination of the abrasion resistance of leather using the rotary platform abraser.

NOTE 1—This test method is similar but not equivalent to ISO 17076-1, and results should not be directly compared between the two methods.

1.2 The values stated in SI units are to be regarded as standard. No other units of measurement are included in this standard.

1.3 *This standard does not purport to address all of the safety concerns, if any, associated with its use. It is the responsibility of the user of this standard to establish appropriate safety, health, and environmental practices and determine the applicability of regulatory limitations prior to use.*

1.4 *This international standard was developed in accordance with internationally recognized principles on standardization established in the Decision on Principles for the Development of International Standards, Guides and Recommendations issued by the World Trade Organization Technical Barriers to Trade (TBT) Committee.*

## 2. Referenced Documents

### 2.1 ASTM Standards:<sup>2</sup>

[D1517 Terminology Relating to Leather](#)

[D1610 Practice for Conditioning Leather and Leather Products for Testing](#)

[D2813 Practice for Sampling Leather for Physical and Chemical Tests](#)

[G195 Guide for Conducting Wear Tests Using a Rotary Platform Abraser](#)

<sup>1</sup> This test method is under the jurisdiction of ASTM Committee D31 on Leather and is the direct responsibility of Subcommittee D31.07 on Physical Properties.

Current edition approved April 1, 2022. Published May 2022. Originally approved in 2006. Last previous edition approved in 2020 as D7255 – 20. DOI: 10.1520/D7255-22E01.

<sup>2</sup> For referenced ASTM standards, visit the ASTM website, [www.astm.org](http://www.astm.org), or contact ASTM Customer Service at [service@astm.org](mailto:service@astm.org). For *Annual Book of ASTM Standards* volume information, refer to the standard's Document Summary page on the ASTM website.

### 2.2 Other Standards:<sup>3</sup>

[ISO 17076-1 Leather-Determination of abrasion resistance Part 1-Taber method](#)

## 3. Terminology

### 3.1 Definitions:

3.1.1 *abraser*—a wear testing instrument, also referred to as a rotary platform tester or abrader.

3.1.2 *abrasion*—the wearing away of any part of a material by rubbing against another surface.

3.1.3 *abrasion cycle*—in *abrasion testing*, one or more movements of the abradant across a material surface, or the material surface across the abradant, that permits a return to its starting position. In the case of the rotary platform test method, it consists of one complete rotation of the specimen.

3.1.4 *durability*—the ability to withstand deterioration or wear out in use, including the effects of abrasion.

3.1.5 *resurface*—the preparation of an abrasive wheel on a refacing disc or diamond tool wheel refacer, prior to use in testing.

3.2 For definitions of other leather terms used in this test method, refer to Terminology [D1517](#).

## 4. Summary of Test Method

4.1 A specimen is abraded using rotary rubbing action under controlled conditions of pressure and abrasive action. The test specimen, mounted on a turntable platform, turns on a vertical axis, against the sliding rotation of two abrading wheels. One abrading wheel rubs the specimen outward toward the periphery and the other, inward toward the center, while a vacuum system removes wear debris generated during the test. The resulting abrasion marks form a pattern of crossed arcs over an area of approximately 30 cm<sup>2</sup>. Resistance to abrasion is evaluated by visual inspection of damage to the specimen or change in mass, as described in Section 14.

<sup>3</sup> Available from American National Standards Institute (ANSI), 25 W. 43rd St., 4th Floor, New York, NY 10036, <http://www.ansi.org>.

\*A Summary of Changes section appears at the end of this standard

## 5. Significance and Use

5.1 The resistance of leather to abrasion, as measured on a testing machine in the laboratory, is generally only one of several factors contributing to wear performance or durability as experienced in the actual use of the material. While “abrasion resistance” (often stated in terms of the number of abrasion cycles) and “durability” are frequently related, the relationship varies with different end uses and different factors may be necessary in any calculation of predicted durability from specific abrasion data. This test method provides a comparative ranking of material performance, which can be used as an indication of relative end-use performance.

5.2 The resistance of leather to abrasion may be affected by factors including test conditions; type of abradant; pressure between the specimen and abradant; mounting or tension of the specimen; and type, kind, or amount of finishing materials.

5.3 Abrasion tests utilizing the rotary platform abramer may be subject to variation due to changes in the abradant during specific tests. Depending on abradant type and test specimen, the abrasive wheel surface may change (that is, become clogged) due to the pick up of finishing or other materials from test specimens. To reduce this variation, the abrasive wheels must be resurfaced at regularly defined intervals.

5.4 The measurement of the relative amount of abrasion may be affected by the method of evaluation and influenced by the judgment of the operator.

## 6. Apparatus

6.1 *Rotary Platform Abraser*,<sup>4</sup> as described in Guide G195 and consisting of the elements described in 6.1.1 – 6.1.5 (see Fig. 1).

<sup>4</sup> Available from Taber® Industries, 455 Bryant Street, North Tonawanda, NY 14120.

6.1.1 A turntable platform, which is removable, that includes a rubber pad, clamp plate and centrally located threaded post and nut. When testing flexible specimens, the turntable platform will also include a clamping ring to secure the specimen to the turntable. The turntable shall be motor driven and mounted so as to produce a circular surface travel of an essentially flat specimen in the plane of its surface,

6.1.2 A motor capable of rotating the turntable platform at a speed of either  $72 \pm 2$  r/min or  $60 \pm 2$  r/min,

6.1.3 A pair of pivoted arms to which the abrasive wheels and accessory weights are attached,

6.1.4 A vacuum suction system and vacuum pickup nozzle to remove debris and abrasive particles from the specimen surface during testing. The height of the vacuum pickup nozzle shall be adjustable, and will have two 8 mm openings. One opening shall be positioned between the two wheels and over the wear path and the other placed diametrically opposite. The distance between the axes of the two openings shall be  $76.0 \pm 1.0$  mm, and

6.1.5 A counter to record the number of abrasion cycles (revolutions) made by the turntable platform.

6.2 *Abrasive Wheels*,<sup>5</sup> which are attached to the free end of the pivoted arms, and are able to rotate freely about horizontal spindles. The abrasive wheels are either resilient (such as type CS-10 or CS-17) or vitrified based (such as type H-18 or H-22), with both types of wheels consisting of hard particles embedded in a binder material and manufactured in different grades of abrasive quality. Other types of wheels, which do not include hard particles embedded in a binder material, may also be used.

<sup>5</sup> The sole source of supply of the apparatus known to the committee at this time is Taber Industries, 455 Bryant Street, North Tonawanda, NY 14120. If you are aware of alternative suppliers, please provide this information to ASTM International Headquarters. Your comments will receive careful consideration at a meeting of the responsible technical committee,<sup>1</sup> which you may attend.

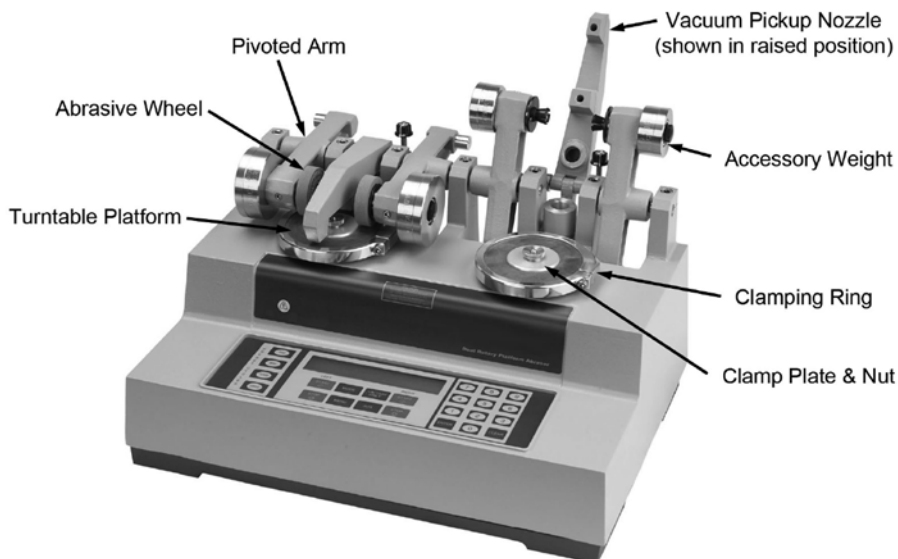

Note: Vacuum Suction System not shown

FIG. 1 Rotary Platform, Abraser

6.2.1 The abrasive wheels shall be cylindrically shaped;  $12.7 \pm 0.3$  mm thick; include an axial hole  $16.0 \pm 0.1$  mm to allow the wheel to be mounted to the pivoted arm; and have an external diameter of  $51.9 + 0.5$  mm when new, and in no case less than 44.4 mm.

6.2.2 Their internal faces shall be  $52.4 \pm 1.0$  mm apart and the hypothetical line through the two spindles shall be  $19.05 \pm 0.3$  mm away from the central axis of the turntable (see Fig. 2). When resting on the specimen, the wheels will have a peripheral engagement with the surface of the specimen, the direction of travel of the periphery of the wheels and of the specimen at the contacting portions being at acute angles, and the angles of travel of one wheel periphery being opposite to that of the other. Motion of the abrasive wheels, in opposite directions, is provided by rotation of the specimen and the associated friction therefrom.

NOTE 2—The H-18 abrasive wheels typically produce a harsher abrasion than the CS-17 abrasive wheels, which produce a harsher abrasion than the CS-10 abrasive wheels.

NOTE 3—The S-35 Tungsten Carbide wheels include 1 mm pitch  $\times$   $45^\circ$

spiral pitch angle, helical teeth cut into its periphery. This wheel does not include hard particles embedded in a binder material, and typically produces severe cutting and abrasion.

6.2.3 Prior to testing, ensure the expiration date has not passed for resilient wheels. Follow the manufacturer’s recommended practice for breaking in new or resurfacing previously used wheel sets (see Section 10).

6.3 *Accessory Weights*, which can be attached to the pivoted arms to increase the load against the specimen to 500 g or 1000 g per wheel (exclusive of the mass of the wheel itself), see 11.1.6. Counterweight attachments of 125 or 175 g are available to reduce the load against the specimen, and can be used with or without the accessory weights.

NOTE 4—Without auxiliary weights or counter weights applied, each arm will apply a load against the specimen of  $250 \pm 1$  g (exclusive of the mass of the wheel itself).

6.4 *Auxiliary Apparatus:*

6.4.1 Refacing disc<sup>4</sup> (S-11), is used for resurfacing of resilient wheels. The refacing disc shall be silicon carbide

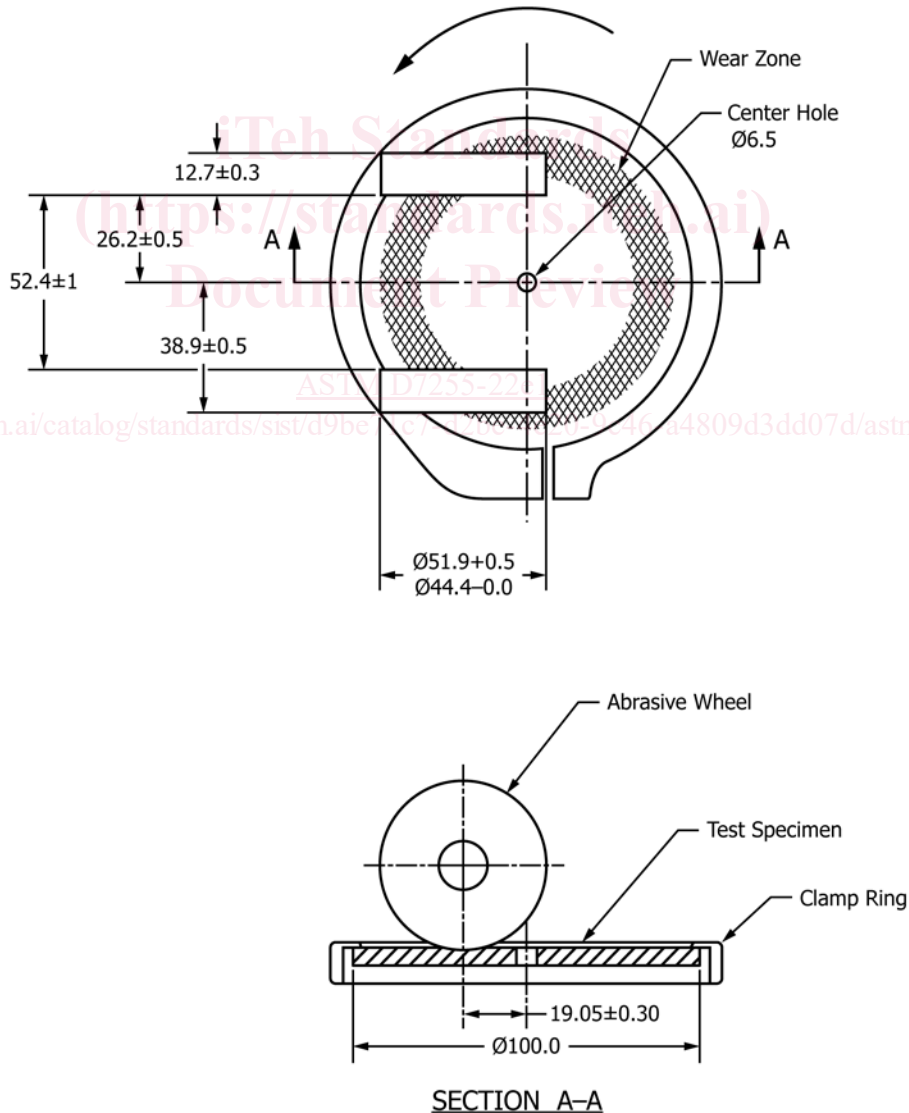

FIG. 2 Arrangement of Rotary Platform Abraser Test Set-up

coated abrasive with an average particle size of 92 μm (150 grit CAMI grade), 102 mm diameter with a 6.5 mm center hole.

6.4.2 Wheel refacer,<sup>4</sup> with a diamond tool for resurfacing vitrified wheels or correcting out of round wheels.

6.4.3 A soft bristle brush, to remove loose particles from the surface of the specimen after testing.

6.4.4 Specimen mounting cards (S-36-1) or equivalent,<sup>4</sup> a 108 mm round mounting card with a 6.5 mm center hole and one side coated with pressure-sensitive adhesive used for mounting specimens. Use of the mounting card is not required when using a clamping ring.

## 7. Sampling

7.1 Take a lot sample as described in Practice D2813, or as agreed upon by the interested parties. Because leather is a natural product, the physical properties may vary depending on location on the hide, side or skin from which the test sample is taken. Random sampling of specimens from a predefined location and orientation minimizes test bias and variability.

## 8. Number and Preparation of Test Specimens

8.1 If the number of specimens to be tested is not specified by agreement between the interested parties, test three specimens.

8.2 Using shears or an appropriate sample cutter, cut the specimen to size. Punch or cut a 6.5 mm diameter hole in the center of the specimen.

8.2.1 When using a specimen mounting card, cut a circular specimen 105 ± 5 mm in diameter. Clean the back of the specimen with a soft bristle brush to remove any loose debris. Mount specimen to a round specimen mounting card (such as S-36-1), ensuring that the specimen is free of folds, creases, or wrinkles.

8.2.2 Alternatively, a sample of 130 ± 5 mm diameter may be used, with or without a mounting card, and secured to the turntable with a clamping ring.

8.3 If the leather has a pattern such as embossment, ensure that the specimen is a representative sampling of the pattern.

8.4 Avoid getting oil, water, grease, and so forth, on the specimen when handling.

## 9. Preparation of Apparatus

9.1 *Load*—A load of 1000 g per wheel should be used, unless otherwise agreed upon by the interested parties.

9.2 *Vacuum Pickup Nozzle*—The height of the vacuum pickup nozzle should be set 7 ± 1 mm above the specimen surface, unless otherwise agreed upon by the interested parties.

9.3 *Vacuum Suction*—The vacuum suction force should be adjusted to remove the abraded particles, but not lift the specimen. A setting of 75 to 100 has been found to be sufficient and should be used, unless otherwise agreed upon by the interested parties.

NOTE 5—Vacuum suction force may be influenced by the condition of the collection bag; empty or replace as required. Any connection or seal leaks will also influence suction force.

9.4 *Selection of Wheel Type*—The CS-10<sup>5</sup> abrasive wheel should be used, unless otherwise agreed upon by the interested parties.

## 10. Standardization of Abrading Wheels

10.1 *Preparation of Resilient Abrading Wheels*—To ensure that the abrading function of the wheels is maintained at a constant level, prepare the resilient wheels (such as type CS-10 or CS-17) following 10.1.1 – 10.1.4.

10.1.1 Mount the selected resilient wheels on their respective flange holders, taking care not to handle them by their abrasive surfaces. Adjust the load on each wheel to 1000 g or the load agreed upon between the interested parties for testing.

10.1.2 Mount the refacing disc (S-11) on the turntable platform and secure using the clamp plate and nut, and clamping ring. Lower the pivoted arms carefully until the wheels rest on the refacing disc. Place the vacuum pick-up nozzle in position and adjust it to a distance of 7 ± 1 mm above the surface of the disc.

10.1.3 Set the counter to ‘zero’ and adjust the vacuum suction force to 100.

10.1.4 If the vacuum system does not turn on automatically at the start of the test, start the vacuum suction and then the turntable. Resurface the wheels by running them for the appropriate number of cycles against the resurfacing disc as shown in Table 1. Each resurfacing disc is good for one 25 or 50 cycle resurfacing operation, after which it must be discarded. Do not touch the surface of the wheels after they are resurfaced.

NOTE 6—*New Set of Wheels (break-in procedure)*—The composition of resilient wheels can make them subject to slight changes of form. Before placing in service a new set of resilient wheels they must be subjected to two (2) resurfacings of 50 cycles to ensure perfect contact of the abrading faces with the specimen surface. The resurfacing disc is used only once (maximum of 50 cycles), therefore this initial resurfacing of new wheels will require two (2) resurfacing discs.

NOTE 7—*Starting a Test with Previously Used Wheels*—Before testing a specimen with previously used wheels, resurface 25 cycles on a new resurfacing disc. Wheels that have not been used for an extended period of time may require a break-in resurfacing like a new set of wheels.

NOTE 8—*Resurfacing During Testing*—To maintain consistency and avoid clogging of wheel faces, the wheels should be resurfaced after every 1000 cycles of use. Remove the specimen after every 1000 cycles (or as agreed by interested parties) and resurface the wheels for 25 cycles with a new resurfacing disc. The sample should be carefully replaced to the original position after resurfacing of the wheels.

10.2 *Preparation of Vitrified Abrading Wheels*—Vitrified wheels (such as type H-18 or H-22) do not require resurfacing unless the abrading surface becomes clogged, chipped or out of round. A diamond tool wheel refacer should be used to correct any of these conditions.

10.3 *Preparation of Tungsten Carbide Abrading Wheels (S-35)*—Use a stiff bristle brush to remove any debris and loose particulate matter lodged between the helical teeth. If

**TABLE 1 Preparation of Abrasive Wheels**

Wheel Status	Resurfacing Cycles
New	2 resurfacings of 50 cycles
Used	25 cycles
During Test (after every 1000 cycles)	25 cycles

necessary, use a solvent based cleaner. Prior to use, inspect the wheels for chips or burrs.

## 11. Calibration

11.1 Verify calibration of the rotary platform abraser as directed by the equipment manufacturer (see [Appendix X1](#)).

11.1.1 *Wheel Position*—The wheels shall be spaced equally on both sides from the wheel-mounting flange to the center of the turntable platform (see [6.2.2](#)). The distance from the inside of the wheel-mounting flange to the center of the specimen holder is  $38.9 \pm 0.5$  mm.

11.1.2 *Wheel Bearings*—The abraser wheel bearings installed in the free end of the pivoting arms to support the wheels should not stick when caused to spin rapidly by a quick driving motion of the forefinger.

11.1.3 *Turntable Platform Position*—The vertical distance from the center of the pivot point of the abraser arms to the top of the specimen holder should be approximately 25 mm. The turntable platform should rotate in the plane of its surface, with a deviation at a distance of 1.6 mm from its periphery of not greater than 0.2 mm. This can be checked with a dial indicator at the top outer edge of the turntable platform.

11.1.4 *Turntable Speed*—The turntable should rotate at the speed stated in [6.1.2](#).

11.1.5 *Vacuum Suction*—At a vacuum level of 100, the suction force shall be 13.7 kPa (139.7 cm of water column) or greater, as measured by a vacuum gage.

11.1.6 *Load*—Since each abraser arm shall weigh  $250 \pm 1$  g (see [Note 4](#)), the accessory load marked 500 g shall weigh  $250 \pm 1$  g and the accessory load marked 1000 g shall weigh  $750 \pm 1$ g.

## 12. Conditioning

12.1 All samples, including mounting cards when required, shall be conditioned for 24 h minimum in standard atmospheric conditions and tested under these conditions as described in Practice [D1610](#).

## 13. Procedure

13.1 Carry out the test in an atmosphere defined in [12.1](#), unless otherwise agreed upon between the interested parties.

13.2 Mount the wheels (see [9.4](#)) on their respective flanged holders, taking care not to handle them by their abrasive surfaces. Prior to testing, ensure that the wheels have been resurfaced according to Section [10](#).

13.3 Select the load to be used and affix it to the rotary platform, double head tester (see [9.1](#)).

13.4 If using a mass loss method of evaluation, weigh the test specimen to the nearest 0.1 mg and record this mass. The specimen should be weighed after mounting on the mounting card, if used.

13.5 Place the test specimen face up, over the rubber mat on the turntable platform. Secure the clamp plate and nut in place to hold the center of the specimen. The clamping ring may also be used to secure the specimen, if needed. Avoid buckling the leather when tightening. If the specimen holder was previously

removed, ensure the holder is properly replaced on the drive shaft of the rotary platform abraser prior to testing.

13.6 Lower the pivoted arms carefully until the wheels rest on the surface of the specimen.

13.7 Position the vacuum pick-up nozzle as outlined in [9.2](#) and adjust vacuum suction force as outlined in [9.3](#).

13.8 Set the counter to zero and program the appropriate number of cycles. If the number of cycles has not been predetermined by mutual agreement between the interested parties, test for 1000 cycles.

13.9 Start the rotary platform abraser and subject the test specimen to abrasion for the specified number of cycles or until wear through of the coating is observed. To determine the point of wear through, stop the instrument at predetermined intervals (for example, 25 cycles) for examination of the test specimen.

13.10 After the test is complete, a soft bristle brush may be used to remove any loose abrasings remaining on the test specimen.

13.11 After testing, raise abraser arms and vacuum pick-up nozzle, then remove the specimen for evaluation. If desired, the turntable platform may be removed from the tester by lifting straight up. This will permit a closer visual inspection of the specimen prior to removal from the turntable platform. If using a mass loss method of evaluation, weigh the test specimen to the nearest 0.1 mg and record this mass. The specimen should be weighed with the mounting card, if used.

## 14. Interpretation of Results

14.1 Visual results of this test may be interpreted from either the number of cycles required to break through the finished surface or, alternatively, by a judgment of the appearance or condition of the specimen after a fixed number of cycles. In either case, comparison of results between parties must include an agreement on a visual grading scale or visual pass/fail criteria (see [Appendix X2](#)).

14.2 If using a mass loss method, calculate mass loss,  $L$ , as follows:

$$L = A - B \quad (1)$$

where,

$A$  = mass of test specimen before abrasion, mg, and

$B$  = mass of test specimen after abrasion, mg.

## 15. Report

15.1 State that the specimens were tested as directed in Test Method D7255. Describe the product sampled and the method of sampling used for the laboratory sampling.

15.2 *Report the following information:*

15.2.1 Temperature and humidity during conditioning and at time of testing,

15.2.2 Type of wheel used,

15.2.3 Load adjustment or counterweight, or both, if used,

15.2.4 Vacuum suction force setting,

15.2.5 Height of vacuum pick-up nozzle, if other than stated in [9.2](#),