



Designation: **E2965--22 E2965 - 22a**

An American National Standard

Standard Test Method for Determination of Low Levels of Heat Release Rate for Materials and Products Using an Oxygen Consumption Calorimeter¹

This standard is issued under the fixed designation E2965; the number immediately following the designation indicates the year of original adoption or, in the case of revision, the year of last revision. A number in parentheses indicates the year of last reapproval. A superscript epsilon (ϵ) indicates an editorial change since the last revision or reapproval.

1. Scope*

1.1 This fire-test-response standard provides a procedure for measuring the response of materials that emit low levels of heat release when exposed to controlled levels of radiant heating with or without an external igniter.

1.2 This test method differs from Test Method E1354 in that it prescribes a different specific test specimen size, specimen holder, test specimen orientation, a direct connection between the plenum and the top plate of the cone heater assembly to ensure complete collection of all the combustion gases (Fig. 1), and a lower volumetric flow rate for analyses via oxygen consumption calorimetry. It is intended for use on materials and products that contain only small amounts of combustible ingredients or components, such as test specimens that yield a peak heat release of $<200 \text{ kW/m}^2$ and total heat release of $<15 \text{ MJ/m}^2$.

NOTE 1—PMMA is typically used to check the general operation of a Cone Calorimeter. PMMA should not be used with this standard as the heat release rate is too high.

1.3 The rate of heat release is determined by measurement of the oxygen consumption as determined by the oxygen concentration and the flow rate in the exhaust product stream. The effective heat of combustion is determined from a concomitant measurement of test specimen mass loss rate, in combination with the heat release rate. Smoke development (an optional measurement) is measured by obscuration of light by the combustion product stream.

1.4 Test specimens shall be exposed to initial test heat fluxes generated by a conical radiant heater. External ignition, when used, shall be by electric spark. The test specimen testing orientation is horizontal, independent of whether the end-use application involves a horizontal or a vertical orientation.

1.5 Ignitability is determined as a measurement of time from initial exposure to time of sustained flaming.

1.6 This test method has been developed for use for material and product evaluations, mathematical modeling, design purposes, and development and research. Examples of material test specimens include portions of an end-use product or the various components used in the end-use product.

1.7 The values stated in SI units are to be regarded as standard. No other units of measurement are included in this standard.

¹ This test method is under the jurisdiction of ASTM Committee E05 on Fire Standards and is the direct responsibility of Subcommittee E05.23 on Combustibility. Current edition approved April 1, 2022; Nov. 1, 2022. Published May 2022; November 2022. Originally approved in 2015. Last previous edition approved in 2017 as E2965-17-22. DOI: 10.1520/E2965-22; 10.1520/E2965-22A.

*A Summary of Changes section appears at the end of this standard

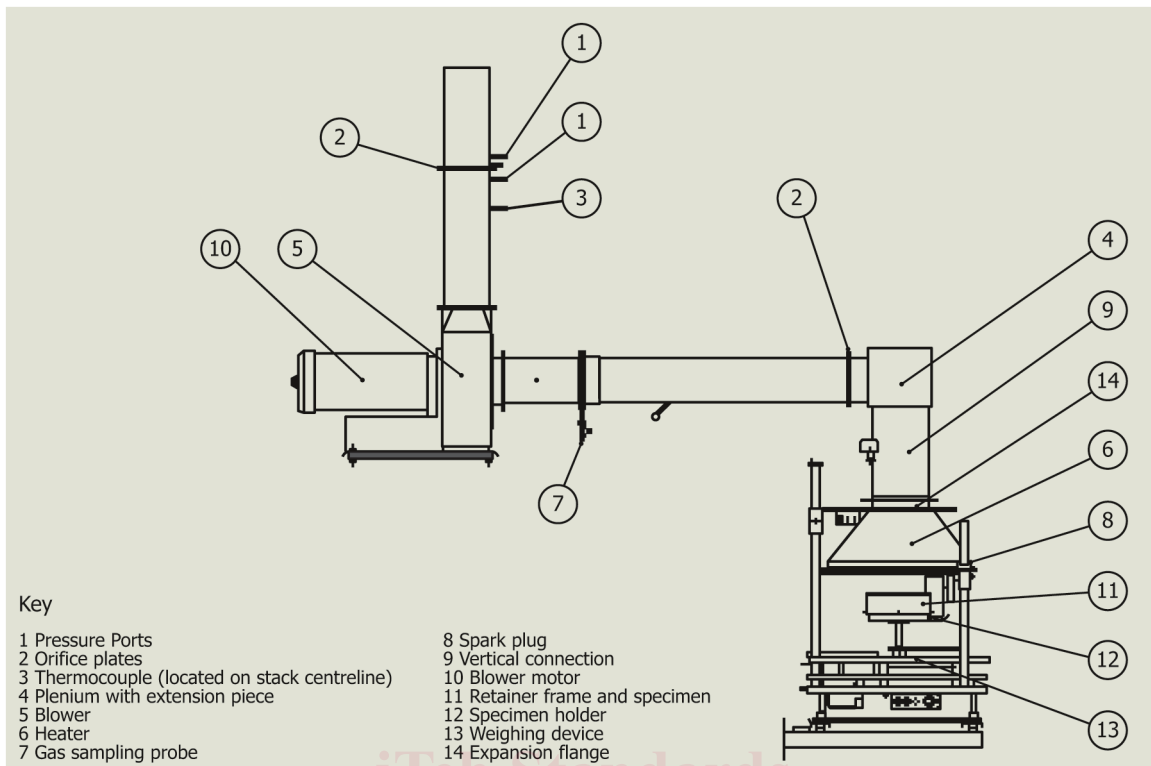

FIG. 1 Modified Cone Calorimeter

1.8 This standard is used to measure and describe the response of materials, products, or assemblies to heat and flame under controlled conditions, but does not by itself incorporate all factors required for fire hazard or fire risk assessment of the materials, products, or assemblies under actual fire conditions.

1.9 Fire testing is inherently hazardous. Adequate safeguards for personnel and property shall be employed in conducting these tests.

1.10 This standard does not purport to address all of the safety concerns, if any, associated with its use. It is the responsibility of the user of this standard to establish appropriate safety, health, and environmental practices and determine the applicability of regulatory limitations prior to use. For specific hazard statements, see Section 7.

1.11 This international standard was developed in accordance with internationally recognized principles on standardization established in the Decision on Principles for the Development of International Standards, Guides and Recommendations issued by the World Trade Organization Technical Barriers to Trade (TBT) Committee.

2. Referenced Documents

2.1 ASTM Standards:

D5865 Test Method for Gross Calorific Value of Coal and Coke

E176 Terminology of Fire Standards

E603 Guide for Room Fire Experiments

E906 Test Method for Heat and Visible Smoke Release Rates for Materials and Products Using a Thermopile Method

E1354 Test Method for Heat and Visible Smoke Release Rates for Materials and Products Using an Oxygen Consumption Calorimeter

2.2 ISO Standards

ISO 5657-1986 (E) Fire Tests—Reaction to Fire—Ignitability of Building Materials

ISO 5725-2 (1994) Accuracy (Trueness and Precision) of Measurement Methods and Results—Part 2: Basic Method for the Determination of Repeatability and Reproducibility of a Standard Measurement Method

3. Terminology

3.1 *Definitions:* For definitions of terms used in this test method, refer to Terminology E176.

3.1.1 *effective heat of combustion, n*—the amount of heat generated per unit mass lost by a material, product or assembly, when exposed to specific fire test conditions (contrast *gross heat of combustion*).

3.1.1.1 Discussion—

The effective heat of combustion depends on the test method, and is determined by dividing the measured heat release by the mass loss during a specified period of time under the specified test conditions. Typically, the specified fire test conditions are provided by the specifications of the fire test standard that cites effective heat of combustion as a quantity to be measured. For certain fire test conditions, involving very high heat and high oxygen concentrations under high pressure, the effective heat of combustion will approximate the gross heat of combustion. More often, the fire test conditions will represent or approximate certain real fire exposure conditions, and the effective heat of combustion is the appropriate measure. Typical units are kJ/g or MJ/kg.

3.1.2 *gross heat of combustion, n*—the maximum amount of heat per unit mass that theoretically can be released by the combustion of a material, product, or assembly; it can be determined experimentally and only under conditions of high pressure and in pure oxygen (contrast *effective heat of combustion*).

3.1.3 *heat flux, n*—heat transfer to a surface per unit area, per unit time (see also *initial test heat flux*).

3.1.3.1 Discussion—

The heat flux from an energy source, such as a radiant heater, can be measured at the initiation of a test (such as Test Method E1354 or Test Method E906) and then reported as the initial test heat flux, with the understanding that the burning of the test specimen can generate additional heat flux to the specimen surface. The heat flux can also be measured at any time during a fire test, for example as described in Guide E603, on any surface, and with measurement devices responding to radiative and convective fluxes. Typical units are kW/m², W/cm², or BTU/(s ft²).

3.1.4 *ignitability, n*—the propensity for ignition, as measured by the time to sustained flaming, in seconds, at a specified heating flux.

3.1.5 *initial test heat flux, n*—the heat flux set on the test apparatus at the initiation of the test (see also *heat flux*).

3.1.5.1 Discussion—

The initial test heat flux is the heat flux value commonly used when describing or setting test conditions.

3.1.6 *oxygen consumption principle, n*—the expression of the relationship between the mass of oxygen consumed during combustion and the heat released.

3.1.7 *smoke obscuration, n*—reduction of light transmission by smoke, as measured by light attenuation.

3.2 Definitions of Terms Specific to This Standard:

<https://standards.iteh.ai/catalog/standards/sist/d41171e9-2e4b-43e4-b8f5-918354e457ea/astm-e2965-22a>

3.2.1 *heat release rate, n*—the heat evolved from the specimen, per unit of time.

3.2.2 *net heat of combustion, n*—the oxygen bomb (see Test Method D5865) value for the heat of combustion, corrected for gaseous state of product water.

3.2.2.1 Discussion—

The net heat of combustion differs from the gross heat of combustion, in that the former assesses the heat per unit mass generated from a combustion process that ends with water in the gaseous state, while the latter ends with water in the liquid state.

3.2.3 *orientation, n*—the plane in which the exposed face of the specimen is located during testing, either vertical or horizontal facing up.

3.2.4 *sustained flaming, n*—existence of flame on or over most of the specimen surface for periods of at least 4 s.

3.2.4.1 Discussion—

Flaming of less than 4 s duration is identified as flashing or transitory flaming.

3.3 Symbols:

- A_s = nominal test specimen exposed surface area, 0.0225 m².
- C = calibration constant for oxygen consumption analysis, m^{1/2} – kg^{1/2} – K^{1/2}.
- Δh_c = net heat of combustion, kJ/kg.
- $\Delta h_{c,eff}$ = effective heat of combustion, kJ/kg.

I	= actual beam intensity.
I_o	= beam intensity with no smoke.
k	= smoke extinction coefficient, m^{-1} .
L	= extinction beam path length, m.
m	= test specimen mass, kg.
m_f	= final test specimen mass, kg.
m_i	= initial test specimen mass, kg.
\dot{m}	= test specimen mass loss rate, kg/s.
ΔP	= orifice meter pressure differential, Pa.
Q''_{tot}	= total heat released, kJ/m^2 (Note that $kJ \equiv kW \cdot s$).
\dot{q}	= heat release rate, kW.
\dot{q}''	= heat release rate per unit area, kW/m^2 .
\dot{q}''_{max}	= maximum heat release rate per unit area (kW/m^2).
\dot{q}''_{180}	= average heat release rate, per unit area, over the time period starting at t_{ig} and ending 180 s later (kW/m^2).
r	= repeatability (the units are the same as for the variable being characterized).
R	= reproducibility (the units are the same as for the variable being characterized).
r_O	= stoichiometric oxygen/fuel mass ratio (-).
s_r	= sample-based standard deviation estimate for repeatability (same units as r).
s_R	= sample-based standard deviation estimate for reproducibility (same units as R).
t	= time, s.
t_d	= oxygen analyzer delay time, s.
t_{ig}	= time to sustained flaming (s).
ρ	= density (kg/m^3).
Δt	= sampling time interval, s.
T_e	= absolute temperature of gas at the orifice meter, K.
V	= volume exhaust flow rate, measured at the location of the laser photometer, m^3/s .
X_{O_2}	= oxygen analyzer reading, mole fraction O_2 (-).
$X_{O_2}^0$	= initial value of oxygen analyzer reading (-).
$X_{O_2}^1$	= oxygen analyzer reading, before delay time correction (-).
σ_f	= specific extinction area, for smoke, m^2/kg .
σ_r	= repeatability standard deviation (same units as r).
σ_R	= reproducibility standard deviation (same units as R).

4. Summary of Test Method

4.1 This test method is based on the observation that, generally, the net heat of combustion is directly related to the amount of oxygen required for combustion. The relationship, known as the oxygen consumption principle, is that approximately 13.1×10^3 kJ of heat are released per 1 kg of oxygen consumed. Test specimens in the test are burned in ambient air conditions, while being subjected to a predetermined initial test heat flux. In the test, the test specimens are exposed to a pre-determined initial test heat flux, either with or without the added use of a spark igniter. The primary measurements are oxygen concentrations and exhaust gas flow rate, which are used to determine heat release rate and total heat released. Additional measurements include the mass-loss rate of the test specimen, the time to sustained flaming and (optionally) smoke obscuration, or as required in the relevant material or performance standard.

4.2 Prior to testing any material using this test method, assurance shall be given to the test laboratory that the material to be tested will not generate excessive heat when tested, for example by complying with 4.2.1 or with 4.2.2.

4.2.1 The material shall be tested to Test Method E1354 at the same initial test heat flux and yield a peak heat release rate of <200 kW/m^2 and a total heat release of <15 MJ/m^2 , as required in 11.1.

4.2.2 In lieu of conducting the test with Test Method E1354, the test requestor is permitted to provide alternate evidence that the material to be tested will meet the heat release requirements of 4.2, as required in 11.2.

5. Significance and Use

5.1 This test method is used primarily to determine the heat evolved in, or contributed to, a fire involving materials or products that emit low levels of heat release. The recommended use for this test method is for materials with a total heat release rate measured of less than 10 MJ over the first 20 min test period, and which do not give peak heat release rates of more than 200 kW/m^2 for periods extending more than 10 s. Also included is a determination of the effective heat of combustion, mass loss

rate, the time to sustained flaming, and (optionally) smoke production. These properties are determined on small size test specimens that are representative of those in the intended end use.

5.2 This test method is applicable to various categories of products and is not limited to representing a single fire scenario.

5.3 This test method is not applicable to end-use products that do not have planar, or nearly planar, external surfaces.

6. Apparatus

6.1 General:

6.1.1 The test apparatus shall be as described in Test Method E1354 with the changes described below. Fig. 1 shows an overview of the apparatus.

6.1.2 All dimensions given in the figures that are followed by an asterisk are mandatory, and shall be followed within nominal tolerances of ± 1 mm, unless otherwise specified.

6.1.3 Additional details describing features and operation of the test apparatus are given in Ref (2).

6.2 Conical Heater:

6.2.1 The heater shall be similar to that used in Test Method E1354, but it shall be of a larger format and constructed such that it is capable of producing irradiance on the surface of the test specimen of up to 80 kW/m^2 . The irradiance shall be uniform within the central ~~100 mm~~ 100 mm area of the exposed test specimen surface, to within ± 2 % and within ± 3 % over the entire surface of the specimen. The heater shall consist of electrical heater rods, tightly wound into the shape of a truncated cone. The heater shall be encased on the outside with a double-wall stainless steel cone, packed with a refractory fiber material of approximately ~~100–100 kg~~ 100 kg kg/m^3 density.

6.3 Test Specimen Mounting:

6.3.1 The specimen holder is shown in Fig. 2. The bottom shall be constructed of 2.4 mm nominal stainless steel, and it shall have outside dimensions of 156 mm by 156 mm by a 25 mm height (tolerance in dimensions: ± 2 mm).

6.3.1.1 An open stainless steel square, 59 mm in inside dimensions, shall be spot welded to the underside of the specimen holder, to facilitate the centering of the test specimen under the cone heater. The leading edge of the open square underneath the specimen holder, which is the one opposite the handle, is optional. The open square on the bottom of the specimen holder shall be designed to seat with the sample mount assembly located at the top of the load cell, ensuring that the specimen holder is centered with respect to the cone heater.

6.3.2 The bottom of the specimen holder shall be lined with a layer of low density (nominal density 65 kg/m^3) refractory fiber blanket with a thickness of at least 13 mm. The distance between the bottom surface of the cone heater and the top of the test specimen shall be adjusted to be 25 mm.

6.3.2.1 If a test has been conducted and there was physical contact of the test specimen with the spark igniter or the cone baseplate, that test shall be deemed invalid.

6.3.3 *Intumescent Materials*—The testing technique to be used when testing intumescent test specimens shall be documented in the test report. Options include those described in 6.3.3.1 – 6.3.3.3.

6.3.3.1 Use a retainer frame or edge frame (Fig. 3).

NOTE 2—The edge frame is used to reduce unrepresentative edge burning of test specimens.

6.3.3.2 Use a wire grid.

NOTE 3—The wire grid is used for retaining test specimens prone to delamination, and is suitable for several types of intumescent test specimens.

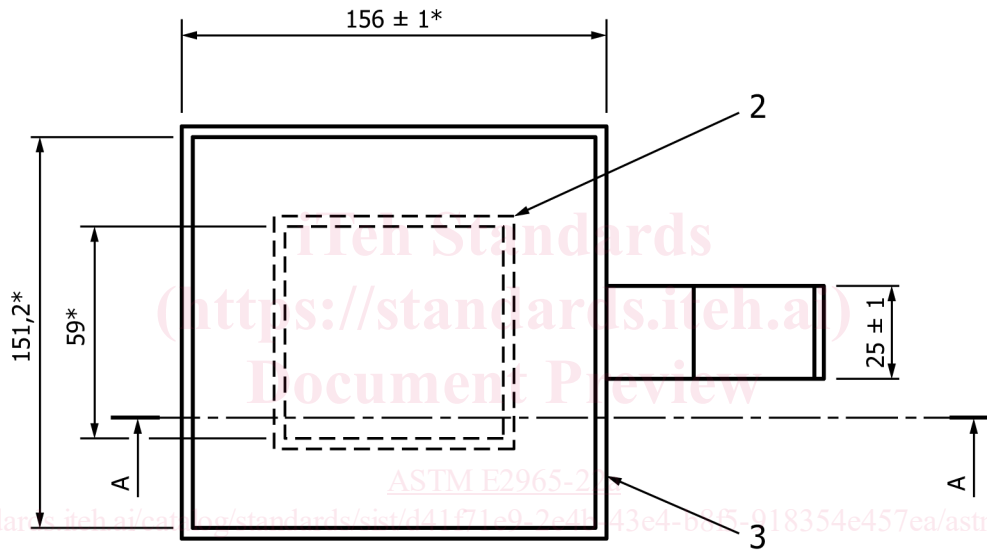
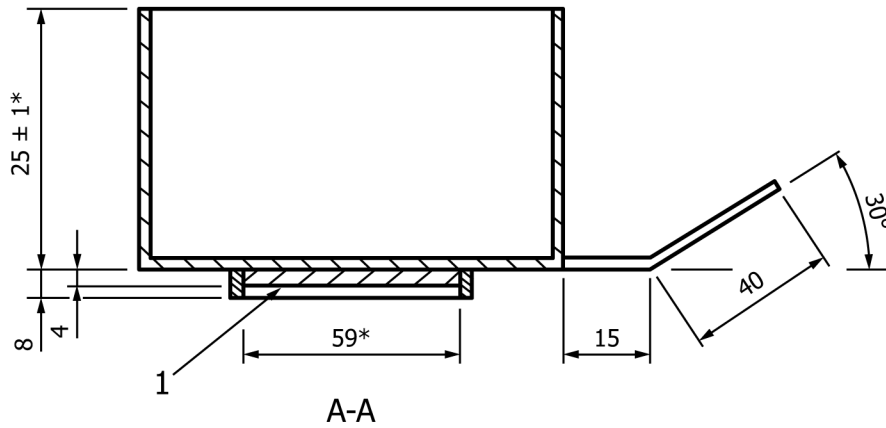

FIG. 2 Specimen Holder

NOTE 1—All dimensions are in millimetres.
 NOTE 2—* Indicates a critical dimension.

6.3.3.3 Use a special mounting procedure suitable for the test specimen to be tested.

6.3.4 Unstable materials that warp so that the exposed surface of the test specimen is not flat during testing shall be restrained to maintain the surface in a flat orientation. This shall be accomplished with four tie wires, as described in 6.3.4.1 – 6.3.4.4.

6.3.4.1 The four tie wires shall be metal wires, 1.0 mm ± 0.1 mm in diameter and at least 350 mm long.

6.3.4.2 The test specimen shall be prepared as described in Section 8 and then tied with the metal wires.

6.3.4.3 A tie wire shall be looped around the specimen holder assembly so that it is parallel to and 20 mm ± 2 mm away from any of the four sides of the assembly. The ends of the tie wire shall be twisted together such that the wire is pulled firmly against the specimen holder assembly. Trim excess wire from the twisted section before testing.

6.3.4.4 Fit the other three tie wires around the specimen holder assembly in a similar manner, so that each one is parallel to one of the sides of the assembly.

6.4 Gas Sampling—The gas sampling system shall incorporate a pump, a filter to prevent entry of soot, a cold trap to remove most

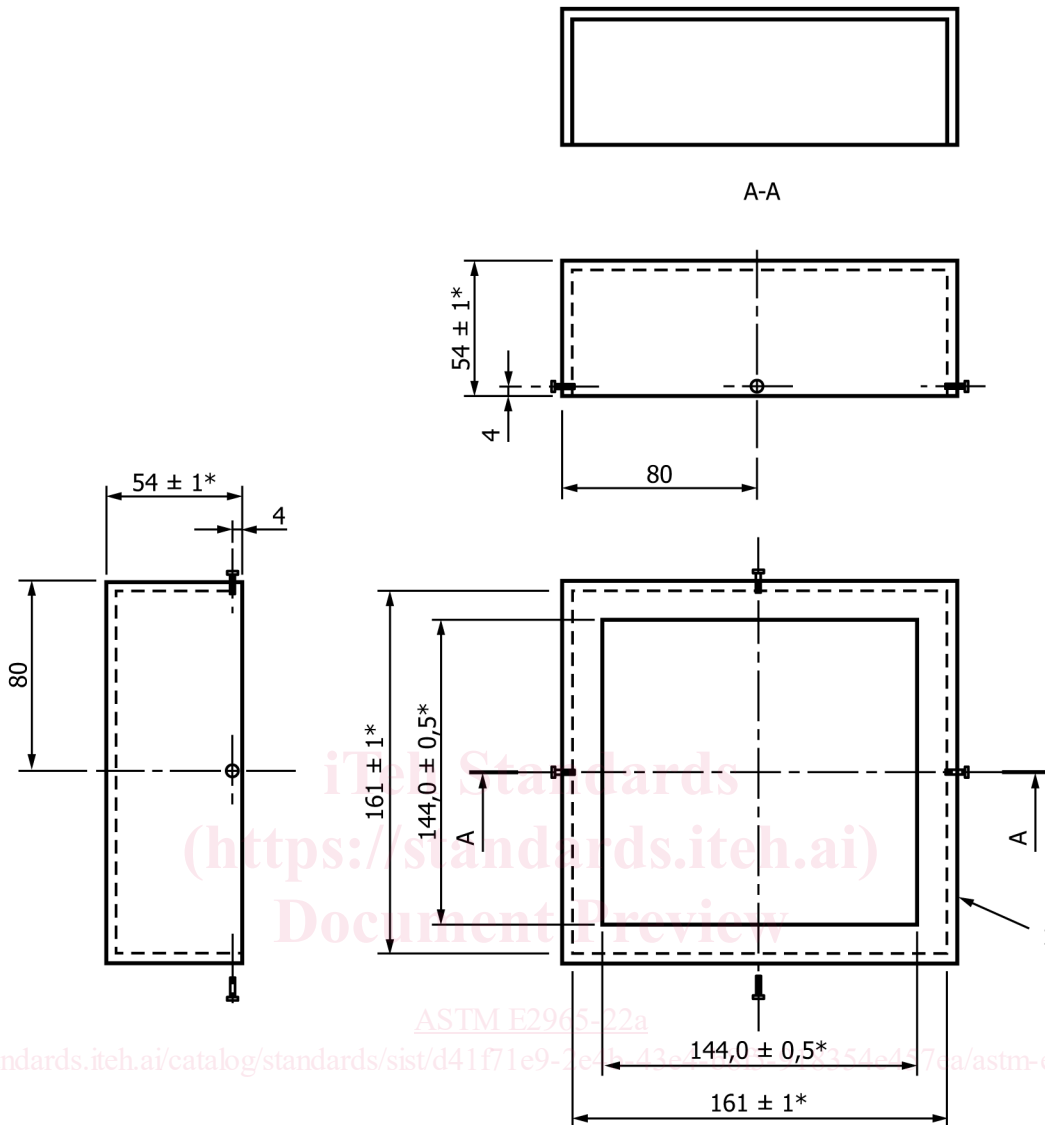

FIG. 3 Retainer Frame

NOTE 1—All dimensions are in millimetres.

of the moisture, a bypass system set to divert all flow except that required for the oxygen analyzer, a further moisture trap, and a trap for carbon dioxide (CO₂) removal; the latter shall be used only if CO₂ is not measured. When a CO₂ trap is used, the sample stream entering the oxygen analyzer must be fully dry; some designs of CO₂ traps require an additional moisture trap downstream of the CO₂ trap.

NOTE 4—If an optional CO₂ analyzer is used instead of removing CO₂ from the oxygen analyzer stream, the equations to calculate the rate of heat release will be different from those for the standard case (Section 13) and are, instead, given in Annex A1.

6.5 *Oxygen Analyzer*—The analyzer shall be of the paramagnetic type with a range from 0 to 25 % oxygen. The analyzer shall exhibit a linear response and drift of not more than ± 30 ppm of oxygen over a period of 30 min, and noise of not more than ~~30 ppm~~ 30 ppm of oxygen (root-mean-square value) during this same 30 min period. Since oxygen analyzers are sensitive to stream pressures, the stream pressure shall be regulated (upstream of the analyzer) to allow for flow fluctuations, and the readings from the analyzer compensated with an absolute pressure regulator to allow for atmospheric pressure variations. The analyzer and the absolute pressure regulator shall be located in a constant-temperature environment. The oxygen analyzer shall have a 10 to 90 % response time of less than 12 s.

6.6 *Exhaust Gas System*—The exhaust gas system shall consist of a centrifugal exhaust fan rated for the operating temperatures,

intake and exhaust ducts for the fan, and an orifice plate flow meter (see Fig. 1). The exhaust system shall be capable of developing flows up to $0.018 \text{ m}^3/\text{s}$, under standard conditions of temperature and pressure.

7. Hazards

7.1 The test procedure involves high temperatures and combustion processes. Therefore, hazards exist for burns, ignition of extraneous objects or clothing, and for inhalation of combustion products. The operator shall use protective gloves for insertion and removal of test specimens. Neither the cone heater nor the associated fixtures shall be touched while hot except with the use of protective gloves. The possibility of the violent ejection of molten hot material or sharp fragments from some kinds of test specimens when irradiated cannot totally be discounted, and eye protection shall be worn.

7.2 The exhaust system shall be checked for proper operation before testing and must discharge into a building exhaust system with adequate capacity. Provision shall be made for collecting and venting any combustion products that are not collected by the normal exhaust system of the apparatus.

7.3 The use of PMMA to check the general operation of the equipment, such as is done for the cone calorimeter (Test Method E1354) is not suitable for this test method. Do not test PMMA with this test method as the heat release rate of this material is too high for adequate safety.

8. Test Specimens

8.1 Size and Preparation:

8.1.1 Test specimens shall be 150 mm by 150 mm in area, up to 50 mm thick, and cut to be representative of the construction of the end-use product. For products of normal thickness greater than 50 mm, the requisite test specimens shall be obtained by cutting away the unexposed face to reduce the thickness to 50 mm. For testing, wrap test specimens in a single layer of aluminum foil, shiny side toward the test specimen, covering the sides and bottom. Foil thickness shall be 0.025 to 0.04 mm.

8.1.2 Some materials, including composites, intumescent materials, other dimensionally unstable materials, materials that warp during testing, and materials that melt and overflow the aluminum foil (8.1.1) during testing, require special mounting and retaining techniques to retain them adequately within the specimen holder during combustion. Section 6.3 includes descriptions of some of the key techniques. The exact mounting and retaining method used shall be specified in the test report. Additional specialized guidance to the operator is provided in Ref (2).

8.1.3 Assemblies shall be tested as specified in 8.1.2 or 8.1.3 as appropriate. Moreover, where thin materials or composites are used in the fabrication of an assembly, the presence of an air gap or the nature of any underlying construction often significantly affects the ignition and burning characteristics of the exposed surface. The influence of the underlying layers must be understood and care taken to ensure that the test result obtained on any assembly is relevant to its use in practice. When the product is a material or a composite that is normally attached to a well-defined substrate, the product shall be tested in conjunction with that substrate, using the recommended fixing technique, for example, bonded with the appropriate adhesive or mechanically fixed.

8.1.4 Products that are thinner than 6 mm shall be tested with a substrate representative of end use conditions, such that the total test specimen thickness is 6 mm or more. In the case of test specimens of less than 6 mm in thickness and that are used with an air space adjacent to the unexposed face, the test specimens shall be mounted so that there is an air space of at least 12 mm between its unexposed face and the refractory fiber blanket. This is achieved by the use of a metal spacer frame.

8.2 *Conditioning*—Test specimens shall be conditioned to moisture equilibrium (constant weight) at an ambient temperature of 23 ± 3 °C and a relative humidity of 50 ± 5 %.

9. Test Environment

9.1 The apparatus shall be located in a draft-free environment in an atmosphere of relative humidity of between 20 % and 80 % and a temperature between 15 °C and 30 °C.

10. Calibration of Apparatus

10.1 *Heater Flux Calibration*—Set the temperature controller to give the desired initial test heat flux by using the heat fluxmeter

at the start of the test day, or after changing to a new flux level. Do not use a specimen holder when the heat fluxmeter is inserted into the calibration position. Operate the cone heater for at least 10 min and ensure that the controller is within its proportional band before beginning this calibration.

10.1.1 Calibrate the heat flux by placing the heat fluxmeter at a distance of 25 mm from the base plate of the cone heater as the upper surface of the test specimen will be placed during testing.

10.1.2 Note that times to sustained flaming measured with different distances between the base plate of the cone heater and the upper surface of the test specimen are likely to be different.

10.2 *Oxygen Analyzer Calibration:*

10.2.1 *Preliminary Calibrations:*

10.2.1.1 The oxygen analyzer delay time must be determined. This is done by arranging for a methane flow rate equivalent to ± 1 kW to the calibration burner. The heater shall not be turned on for this calibration. Record the output of the analyzer as the methane supply, turned on and ignited, reaches a steady value, and then returns to baseline after the supply is cut off. Record the temperature for the exhaust-orifice meter at the same time. Determine the turn-on delay as the time difference between the time when the temperature reading reaches 50 % of its ultimate deflection and the time when the oxygen reading reaches 50 % of its ultimate deflection. Determine the turn-off delay similarly at turn-off. Take the delay time (t_d) as the average of the turn-on delay and turn-off delay. Use this value, t_d , subsequently to time-shift all the oxygen readings.

10.2.1.2 If the oxygen analyzer is equipped with an electric response-time adjustment, set it so that at turn-off there is just a trace of overshoot when switching rapidly between two different calibration gases.

10.2.1.3 The timing of the scans by the data collection system shall be calibrated with a timer accurate to within 1 s in 1 h. The data output shall show event times correct to 3 s.

10.2.2 *Operating Calibrations:* At the start of testing each day, the oxygen analyzer shall be zeroed and calibrated. For zeroing, the analyzer shall be fed with nitrogen gas with the same flow rate and pressure as for the sample gases. Calibration shall be similarly achieved using ambient air and adjusting for a response of 20.95 %. Analyzer flow rates shall be carefully monitored and set to be equal to the flow rate used when testing actual test specimens. After each test specimen has been tested, ensure that a response level of 20.95 % is obtained using ambient air.

10.3 *Heat Release Rate Calibration:*

10.3.1 The heat release calibration shall be performed at the start of testing each day. Methane (purity of at least 99.5 %) shall be introduced into the calibration burner at a flow rate corresponding to 1 kW based on the net heat of combustion of methane (50.0×10^3 kJ/kg) using a precalibrated flowmeter. The flowmeter used shall be an electronic mass flow controller. The electronic mass-flow controller used shall be calibrated periodically against a dry test meter or a wet test meter. The test meter shall be equipped with devices to measure the temperature and pressure of the flowing gas, so that appropriate corrections to the reading may be made. If a wet test meter is used, the readings shall also be corrected for the moisture content. The exhaust fan shall be set to the speed to be used for subsequent testing. The required calculations are given in Section 14.

NOTE 5—Calibration shall be permitted to be performed with the cone heater operating or not, but calibration shall not be performed during heater warm up.

10.4 *Load Cell Calibration*—The load cell shall be calibrated with standard weights in the range of test specimen weight each day of testing, or when the load cell mechanical zero needs to be adjusted. Adjust the load cell mechanical zero if necessary due to different specimen holder tare weights after changing orientation.

10.5 *Smoke Meter Calibration*—The smoke meter (if used) shall be initially calibrated to read correctly for two different value neutral density filters, and also at 100 % transmission. Once this calibration is set, only the zero value of extinction coefficient (± 0.0 ~~to~~ (100 % transmission) normally needs to be verified prior to each test.

11. Assessment of Suitability of Material for Testing to Test Method E2965

11.1 *Testing in Accordance with Test Method E1354*—Before testing any material in accordance with this test method, test the material in accordance with Test Method E1354. Test the material in duplicate at the same incident heat flux to be used in this test method.

11.1.1 The average peak heat release rate of the material in accordance with Test Method E1354 shall be $<200 \text{ kW/m}^2$.

11.1.2 The average total heat release of the material in accordance with Test Method E1354 shall be $<15 \text{ MJ/m}^2$.

11.1.3 If the results of 11.1.1 and 11.1.2 are satisfactory, conduct tests to Test Method E2965.

11.1.4 Report the peak heat release rate and total heat released from Test Method E1354.

11.2 *Alternate Provision of Evidence of Suitability*—Provide alternate suitable evidence that the material to be tested will not exceed the heat release requirement that would make it unsafe for testing.

11.2.1 It is not a requirement that the evidence required in 11.2 be based on heat release data.

12. Procedure

12.1 Preparation:

12.1.1 Verify that either: (a) the suitability testing, in accordance with Test Method E1354, has been performed in accordance with 11.1 or (b) alternate evidence has been provided in accordance with 11.2.

12.1.2 Check the CO₂ trap and the final moisture trap. Replace the sorbents if necessary. Drain any accumulated water in the cold trap separation chamber. Normal operating temperature of the cold trap shall be the lowest temperature at which trap freezing does not occur (approximately $\theta^{\circ}\text{C}$: 0°C).

NOTE 6—If any of the traps or filters in the gas sampling line have been opened during the check, the gas sampling system shall be checked for leaks, for example, by introducing pure nitrogen, at the same flow rate and pressure as for the sample gases, from a nitrogen source connected as close as possible to the ring sampler. The oxygen analyzer must then read zero.

<https://standards.iteh.ai/catalog/standards/sist/d41171e9-2e4b-43e4-b8f5-918354e457ea/astm-e2965-22a>

12.1.3 Turn on power to the cone heater and the exhaust blower. (Power to the oxygen analyzer, load cell, and pressure transducer is not to be turned off on a daily basis.)

12.1.4 Set an exhaust flow rate of $0.012 \text{ m}^3/\text{s} \pm 0.002 \text{ m}^3/\text{s}$. (Under room temperature conditions, this corresponds to approximately 15 g/s .)

12.1.5 Perform the required calibration procedures specified in Section 9. Place an empty specimen holder (with refractory blanket) in place during warm-up and in between tests to avoid excessive heat transmission to the load cell.

12.1.6 Set the initial test heat flux at the value to be used in the test, typically either 50 kW/m^2 or 75 kW/m^2 .

12.1.7 If external ignition is used, position the spark plug holder in the appropriate location for the test to be conducted.

12.2 Test Procedure:

12.2.1 When ready to test, first remove the empty specimen holder.

12.2.2 Insert the radiation shield and position the test specimen, in the appropriate specimen holder, in place. The specimen holder must be at room temperature initially.

12.2.3 Leave the radiation shield in place for a sufficient time to ensure stability of operation (load cell equilibrium), but for no longer than 10 s if the shield is not water cooled. Initiate data collection upon removal of the radiation shield, which signifies the start of the test. The data collection intervals shall be 1 s or less.

12.2.4 Place the test specimen, held in the appropriate holder, in place. The specimen holder shall be centered with respect to the cone heater. The specimen holder shall be at room temperature initially.

12.2.5 Start the data collection. The data collection intervals shall be 1 s or less.

12.2.6 Start the ignition timer if external ignition is to be used. Move the spark plug into place and turn on spark power.

12.2.7 Record the times when flashing or transitory flaming occur; when sustained flaming occurs, record the time, turn off the spark, and remove the spark igniter. If the flame extinguishes in less than 60 s after turning off the spark, reinsert the spark igniter within 5 s and turn on the spark. Do not remove the spark until the entire test is completed. Report these events in the test report.

12.2.7.1 Sustained flaming occurs once a flame exists over most of the test specimen surface for at least 4 s (see 3.2.4). The time to be reported as the time to sustained flaming is the time when the flaming was initially observed, not the time when the 4 s period elapsed.

12.2.8 Collect data for no less than 20 min, until 4 min after any one of the following conditions first occurs:

12.2.8.1 Flaming or other signs of combustion cease,

12.2.8.2 The average mass loss over a 1-min period has dropped below 150 g/m²,

12.2.8.3 The test specimen mass has been consumed and the load cell has returned to the pre-test value (in grams),

12.2.8.4 The oxygen concentration has returned to near the pretest value for 10 min (as evidenced by a heat release rate of below 5 kW/m²), or

12.2.8.5 Until 60 min have elapsed.

12.2.9 Remove specimen holder.

12.2.10 Replace the empty specimen holder.

12.2.11 If the test specimen does not ignite in 30 min, remove and discard, unless the test specimen is showing signs of heat evolution.

NOTE 7—Stop testing if explosive spalling or excessive swelling occurs. Some of the procedures described in 8.1 are useful in mitigating these effects.

NOTE 8—If in the tests at 0.012 m³/s smoke leaking occurs then stop the test, discard the data and retest at an exhaust flow rate of 0.018 m³/s. The procedure in 10.2 must be repeated before testing at the new exhaust flow rate.

12.2.12 Unless otherwise specified in the material or performance standard, make three determinations and report as specified in Section 15.

12.2.13 Compare the 180-s mean heat release rate readings (specified in Section 15) for the three test specimens. If any of these mean readings differ by more than 10 % from the average of the three readings, then test a further set of three test specimens. In such cases, the average to be reported shall be the average for the set of six readings.

13. Test Limitations

13.1 The test data have limited validity if any of the following occur:

13.1.1 The test specimen melts sufficiently to overflow the specimen tray,

13.1.2 Explosive spalling occurs, or

13.1.3 The test specimen swells sufficiently prior to ignition to touch the spark plug or swells up to the plane of the heater base plate during combustion.