



Designation: D2844/D2844M – 18^{ε1}

Standard Test Method for Resistance *R*-Value and Expansion Pressure of Compacted Soils¹

This standard is issued under the fixed designation D2844/D2844M; the number immediately following the designation indicates the year of original adoption or, in the case of revision, the year of last revision. A number in parentheses indicates the year of last reappraisal. A superscript epsilon (ϵ) indicates an editorial change since the last revision or reappraisal.

^{ε1} NOTE—Adjunct stock numbers were editorially updated in December 2022.

1. Scope*

1.1 This test method covers the procedure for testing both treated and untreated laboratory compacted soils or aggregates with the stabilometer and expansion pressure devices to obtain results indicative of performance when placed in the base, subbase, or subgrade of a road subjected to traffic.

1.2 *Units*—The values stated in either SI units or inch-pound units presented in brackets are to be regarded separately as standard. The values stated in each system may not be exact equivalents; therefore, each system shall be used independently of the other. Combining values from the two systems may result in non-conformance with the standard. However, use of equipment manufactured to be readable in inch-pound units only should not be considered as non-conformance to the test method. Many stabilometers and expansion pressure devices are manufactured to be readable in inch-pound units only.

1.3 All observed and calculated values shall conform to the guidelines for significant digits and rounding established in Practice D6026.

1.3.1 For purposes of comparing measured or calculated value(s) with specified limits, the measured or calculated value(s) shall be rounded to the nearest decimal or significant digits in the specified limits.

1.3.2 The procedures used to specify how data are collected/recorded or calculated, in this standard are regarded as the industry standard. In addition, they are representative of the significant digits that generally should be retained. The procedures used do not consider material variation, purpose for obtaining the data, special purpose studies, or any considerations for the user's objectives; and it is common practice to increase or reduce significant digits of reported data to be commensurate with these considerations. It is beyond the scope of this standard to consider significant digits used in analytical methods for engineering design.

¹ This test method is under the jurisdiction of ASTM Committee D18 on Soil and Rock and is the direct responsibility of Subcommittee D18.08 on Special and Construction Control Tests.

Current edition approved May 1, 2018. Published May 2018. Originally approved in 1969. Last previous edition approved in 2013 as D2844 – 13. DOI: 10.1520/D2844_D2844M-18E01.

1.4 *This standard does not purport to address all of the safety concerns, if any, associated with its use. It is the responsibility of the user of this standard to establish appropriate safety, health, and environmental practices and determine the applicability of regulatory limitations prior to use.*

1.5 *This international standard was developed in accordance with internationally recognized principles on standardization established in the Decision on Principles for the Development of International Standards, Guides and Recommendations issued by the World Trade Organization Technical Barriers to Trade (TBT) Committee.*

2. Referenced Documents

2.1 ASTM Standards:²

C670 Practice for Preparing Precision and Bias Statements for Test Methods for Construction Materials

D653 Terminology Relating to Soil, Rock, and Contained Fluids

D3740 Practice for Minimum Requirements for Agencies Engaged in Testing and/or Inspection of Soil and Rock as Used in Engineering Design and Construction

D6026 Practice for Using Significant Digits and Data Records in Geotechnical Data

E4 Practices for Force Calibration and Verification of Testing Machines

E11 Specification for Woven Wire Test Sieve Cloth and Test Sieves

2.2 AASHTO Documents:

T 190 Test Method for Resistance *R*-Value and Expansion Pressure of Compacted Soils³

² For referenced ASTM standards, visit the ASTM website, www.astm.org, or contact ASTM Customer Service at service@astm.org. For *Annual Book of ASTM Standards* volume information, refer to the standard's Document Summary page on the ASTM website.

³ Available from American Association of State Highway and Transportation Officials (AASHTO), 444 N. Capitol St., NW, Suite 249, Washington, DC 20001, <http://www.transportation.org>.

*A Summary of Changes section appears at the end of this standard

2.3 ASTM Adjuncts:⁴

Exudation Device
Expansion Pressure Apparatus
Stabilometer

2.4 CALTRANS Standard:⁵

California Test 103 Method of Test For Calibration of
Expansion Pressure Devices

3. Terminology

3.1 For definitions of terms in this test method, refer to Terminology **D653**.

4. Significance and Use

4.1 This test method is used to measure the potential strength of subgrade, subbase, and base course materials for use in road and airfield pavements. The R-value is used by some agencies as criteria for acceptance of aggregates for base course and bituminous courses.

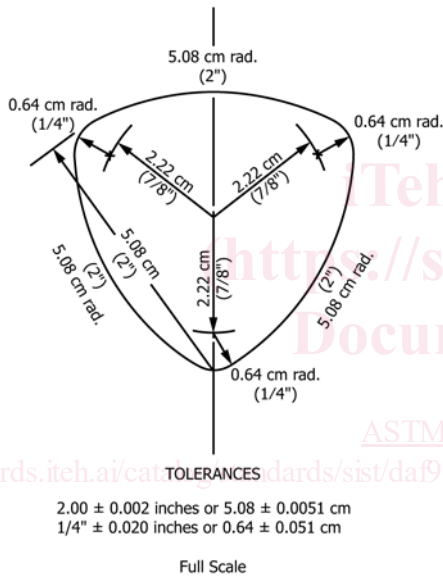

FIG. 1 Tamper Shoe for Kneading Compactor

4.2 The expansion pressure testing has been used in conjunction with the R-value test to determine cover requirements (thickness) and construction controls to reduce pavement distortion from expansive subgrade soils.

NOTE 1—The quality of the result produced by this standard is dependent on the competence of the personnel performing it, and the suitability of the equipment and facilities used. Agencies that meet the criteria of Practice **D3740** are generally considered capable of competent and objective testing/sampling/inspection/etc. Users of this test method are cautioned that compliance with Practice **D3740** does not in itself ensure reliable results. Reliable results depend on many factors; Practice

⁴ Copies of detailed drawings of the apparatus shown in Figs. 4 (1 drawing), 7 (4 drawings), 10 and 11 (7 drawings) are available at a nominal cost from ASTM International Headquarters. Request Adjunct Nos. [ADJD284401-E-PDF](#), [ADJD284402-E-PDF](#), and [ADJD284403-E-PDF](#) respectively.

⁵ Available from State of California Department of Transportation (CALTRANS), P.O. Box 942873, Sacramento, CA 94273-0001, <http://www.dot.ca.gov>. Proving Lever Assembly detailed drawings are available here as well.

D3740 provides a means of evaluating some of those factors.

5. Apparatus

NOTE 2—The inch-pound dimensions [presented in brackets], found in this section are for equipment commonly available in the United States.

5.1 *Kneading Compactor*, capable of applying an average contact pressure of 2410 ± 110 kPa [350 ± 16 psi] to the tamper foot shown in Fig. 1 and with provisions for maintaining this pressure during changes in sample height. The load-time trace shall be free of “chatter” or evidence of impact-associated changes in slope. The rise time for application of foot pressure, in the range from 240 to 2070 kPa [35 to 300 psi], shall be 0.07 to 0.20 seconds. The dwell time, measured at 2070 kPa [300 psi] foot pressure, shall be 0.15 to 0.45 seconds. The pressure-release or removal time shall not be greater than 0.60 seconds.

5.1.1 The compactor shall include a counter for measuring the number of tamps applied to a specimen and a mold holder, for use in compacting specimens, that rotates equally between tamps to give 5 to 7 tamps per revolution of the mold. The holder shall firmly restrain the mold during compaction. The base of the mold holder shall have a metal plate 100.8 mm [$3 \frac{3}{32}$ in.] in diameter and 12.7 mm [0.5 in.] in height, to which is cemented a rubber disk having a diameter of 100.0 mm [$3 \frac{15}{16}$ in.] and a thickness of 3.2 mm [$\frac{1}{8}$ in.]. The plate shall be an integral part of the base of the mold holder. The compactor shall also include a trough for feeding the sample into the mold in 20 increments (Fig. 2). Troughs with a semicircular cross section of 39 cm^2 [6.0 in.^2] in area and 50.8 cm [20 in.] in length have proven satisfactory.

5.2 *Compression Testing Machine*, with a minimum capacity of 45 kN [10 000 lbf] and satisfying the requirements of Practices **E4**.

5.3 *Mold*, 101.6 ± 0.05 mm [4.0 ± 0.002 in.] inside diameter by 127 ± 0.20 mm [5.0 ± 0.008 in.] high. (See Fig. 3 for surface roughness.)

5.4 *Rubber Disks*, 100 mm [$3 \frac{15}{16}$ in.] in diameter by 3 mm [$\frac{1}{8}$ in.] thick and having a durometer hardness of 60 ± 15 .

5.5 *Metal Follower*, solid-walled, metal specimen follower 100.33 ± 0.13 mm [3.95 ± 0.005 in.] in outside diameter by 127 mm [5.0 in.] long.

5.6 *Exudation Indicator Device*, as shown in Fig. 4⁴ and Fig. 5.

5.7 *Phosphor Bronze Disk*, as shown in Fig. 6.

5.8 *Filter Paper*, 100 mm [4.0 in.] in diameter and 0.15 mm [0.006 in.] thick, with a smooth surface, medium filtering speed, medium retention.

5.9 *Filter Paper*, 110 mm [4.3 in.] in diameter and 0.15 mm [0.006 in.] thick, with a creped surface, medium-fast filtering speed, and medium retention.

5.10 *Expansion-Pressure Device*, with accessories as shown in Fig. 7.⁴ There should be at least three of these devices for each sample to be tested within a day’s time.

5.11 *Deflection Gage*, with divisions of 0.002 mm [0.0001 in.] and an allen wrench as shown in Fig. 7.



FIG. 2 Compactor with Sample Feed Trough

[ASTM D2844/D2844M-18e1](#)

[https://www.astm.org/standards/D2844](#) 5.12 Proving Lever Assembly, as shown in Fig. 8 and Fig. 9.⁵ **7. Preparation of Soil Specimens** [D2844-d2844m-18e1](#)

5.13 Stabilometer, with accessories, as shown in Fig. 10 and Fig. 11.⁴

5.14 Standard Metal Specimen, 101.6 mm [4.0 in.] in outside diameter by 152.2 mm [6.0 in.] high as shown in Fig. 11.

5.15 Balance, 5000-g capacity, accurate and readable to 1 g.

5.16 Sieves, 25.0 mm [1 in.], 19.0 mm [$\frac{3}{4}$ in.] and 4.75 mm [No. 4] conforming to the requirements of Specification E11.

5.17 Miscellaneous Equipment, including mixing pans, spoons, spatulas, and gallon cans with close-fitting lids.

6. Soil Preparation

6.1 Remove any coatings from coarse aggregate and break clay lumps to pass the 4.75-mm [No. 4] sieve.

6.2 Adjust the soil gradation when material is retained on the 19.0-mm [$\frac{3}{4}$ -in.] sieve. When 75 % or more passes the 19.0-mm [$\frac{3}{4}$ -in.] sieve, use that part of the sample passing the 19.0-mm [$\frac{3}{4}$ -in.] sieve. If less than 75 % of the sample passes the 25.0-mm [1-in.] sieve, use that part of the sample passing the 25.0-mm [1-in.] sieve. See Table 1 for a sample calculation.

7.1 Thoroughly mix four approximately 1200-g [2.7-lb] samples of soil with the amount of water estimated to equal one half to two thirds of the water required to produce saturation as defined in 7.3 and 7.4. Place the samples in covered containers and allow them to stand overnight. Just prior to compaction, mix the samples with the final amount of water required to produce saturation. The first sample is used as a pilot specimen to assist in determining the final amount of water required.

7.2 Weigh out enough material to fabricate a compacted sample 101.6 mm [4.0 in.] in diameter by 63 mm [2.5 in.] high. Compacted specimens having heights from 62 to 65 mm [2.45 to 2.55 in.] are acceptable. Compact the soil into the mold by means of the kneading compactor as follows: Place the mold over the mold holder. Adjust the mold for approximately 3-mm [$\frac{1}{8}$ -in.] clearance between the lower edge of the mold and base of the mold holder. A metal angle bracket of 3-mm [$\frac{1}{8}$ -in.] thickness and approximately 37.5 mm [$1\frac{1}{2}$ in.] length placed on the base of the mold holder have proven satisfactory. Alternately, tighten the set screw, if available, on the mold holder. Spread the sample along the length of the trough. With the compactor-foot pressure set at 1720 ± 170 kPa [250 ± 25 psi], feed 75 mm [3.0 in.] of the soil from the trough into the

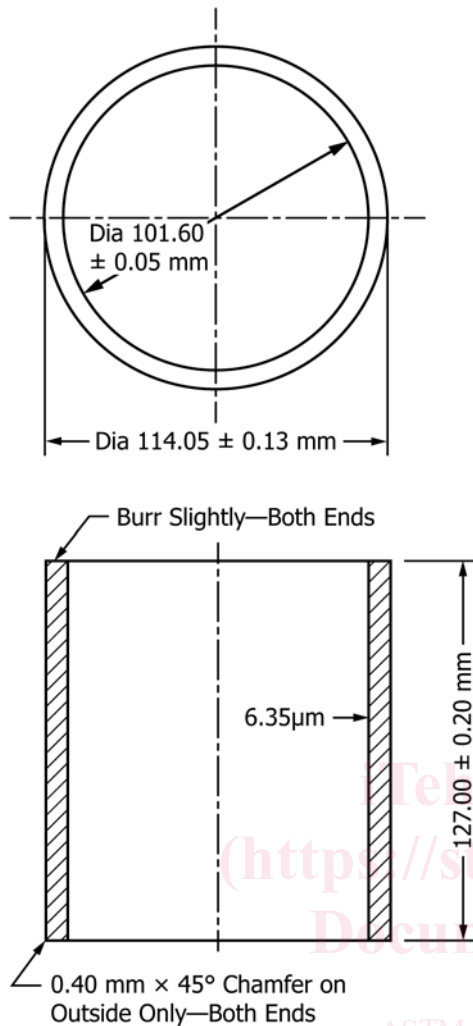

FIG. 3 Mold

NOTE 1—Inside roughness is obtained by smooth machining inside to required diameter of 101.6 ± 0.05 mm [4.000 ± 0.002 in.] followed on final operation with a boring tool bit ground to a 90° point with sharp point ground flat measuring 0.025 to 0.075 mm [0.001 to 0.003 in.] across. Depth of cut is 0.050 mm [0.002 in.] with 0.25 mm [0.010 in.] feed using sulfur-based oil coolant.

mold. Redistribute the sample remaining in trough as needed to feed the balance of the soil into the mold in 20 equal increments with one application of the ram after each increment. Allow 10 additional tamps to level the soil, then place a rubber disk on top of the specimen. Remove the shim from under the mold or loosen the set screw. Apply 100 additional tamps with a foot pressure of 2410 kPa [350 psi]. Stop compacting the soil at any time before 100 tamps if water appears around the bottom of the mold.

NOTE 3—Use lower compaction pressures when necessary to limit penetration of the ram into the soil to not greater than 6 mm [$\frac{1}{4}$ in.].

7.3 Remove the mold containing the compacted specimen from the compactor. Level the tamped surface by hand tamping with a 38-mm [1.5-in.] diameter rod. Remove the rubber disks. Place a phosphor-bronze disk on the tamped surface of the soil and place a 100-mm filter paper on top of the bronze disk. Invert the mold and place it on the exudation device so that the

filter paper is on the bottom. Place the solid walled, metal specimen follower into the mold. Using the compression testing machine, apply a uniformly increasing pressure to the soil at the rate of 8900 N [2000 lbf]/min. Water should be exuded from the soil at 2070 kPa [300 psi] as evidence that enough moisture is present to produce saturation. Stop the loading and record the exudation pressure to the nearest 10 kPa [1 psi] when either five of the six indicator lights on the exudation indicator device are lighted or three indicator lights are lighted and free water is visible around the bottom of the mold. Do not exceed a exudation pressure of 5520 kPa [800 psi].

7.4 Mold at least two more specimens with different amounts of moisture so that a range of exudation pressures from 690 to 5520 kPa [100 to 800 psi] is obtained bracketing the 2070 kPa [300 psi] value. For some high volume-change soils, additional specimens having exudation pressures lower than 690 kPa [100 psi] may be necessary to obtain expansion pressures that are low enough to provide a suitable range of data for a complete expansion pressure analysis of the soil.

NOTE 4—Occasionally, material from very plastic clay-test specimens will extrude from under the mold and around the follower ram during the loading operation. If this occurs when the 5520-kPa [800-psi] point is reached and fewer than five lights are lighted, the soil should be reported as less than 5 R-value. Coarse granular materials and clean sands may require the use of paper baskets to permit testing.

8. Calibration of Expansion-Pressure Apparatus

8.1 Calibrate the spring-steel bar of the expansion-pressure device (Fig. 7) by applying upward measured loads at the center of the bar and measuring the respective deflections of the bar with the deflection dial indicator using the following procedure:

8.2 Place the proving lever base on the expansion-pressure device turntable. Place the proving lever arm atop the base so that the weight-suspension notches face upward

8.2.1 Hold the base and lever arm assemble stationary while raising the turntable until the lever arm's roller bearing presses upward against the spring-steel bar. Continue raising the turntable until the lever arm rotates into a horizontal position. A small bubble level placed atop the arm has proven satisfactory.

8.2.2 Place the deflection gauge on top of the expansion-pressure device so the dial indicator stem rests against the top of the spring-steel bar.

8.2.3 Ensure that the proving lever roller bearing is seated against the spring-steel bar aligned directly under the deflection dial indicator stem. Adjust the dial indicator until the deflection reads zero.

8.3 Place the proving lever weight on the arm.

8.3.1 When the weight is in the innermost notch it will apply an upward 36 N [8 lbf] load against the spring-steel bar of the expansion-pressure device. The dial indicator should register 0.053 mm [0.0021 in.].

8.3.1.1 Repeat this step for the remaining three notches.

8.3.1.2 The second notch will produce an upward 71 N [16 lbf] load. The dial indicator should register 0.107 mm [0.0042 in.].



FIG. 4 Circular Exudation-Indicator Device

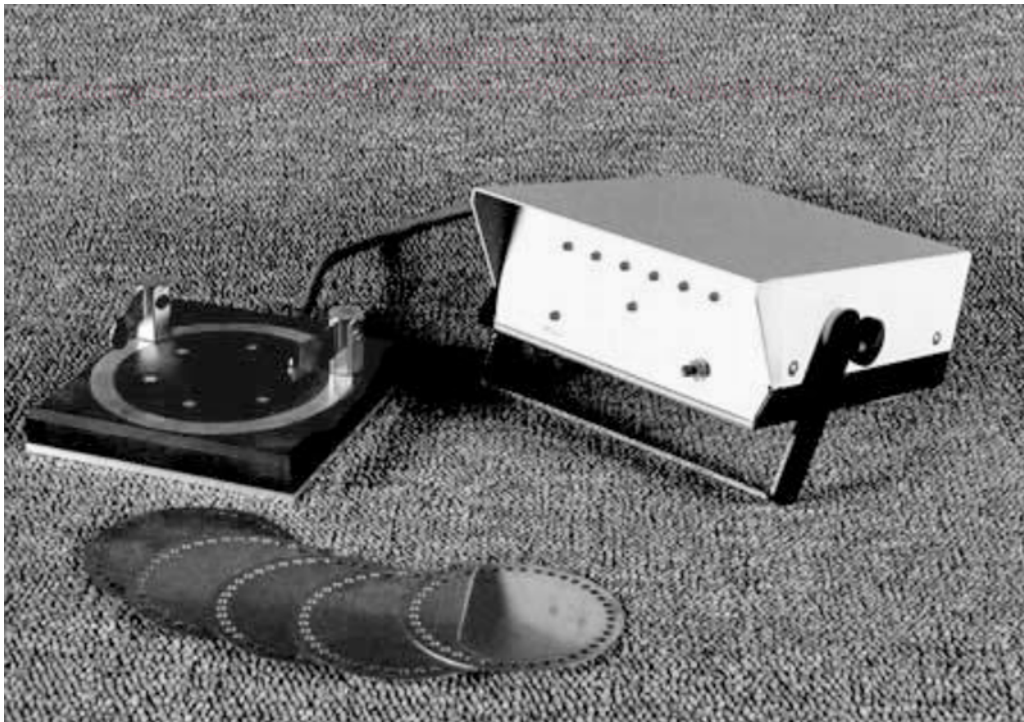

FIG. 5 Linear Exudation-Indicator Device

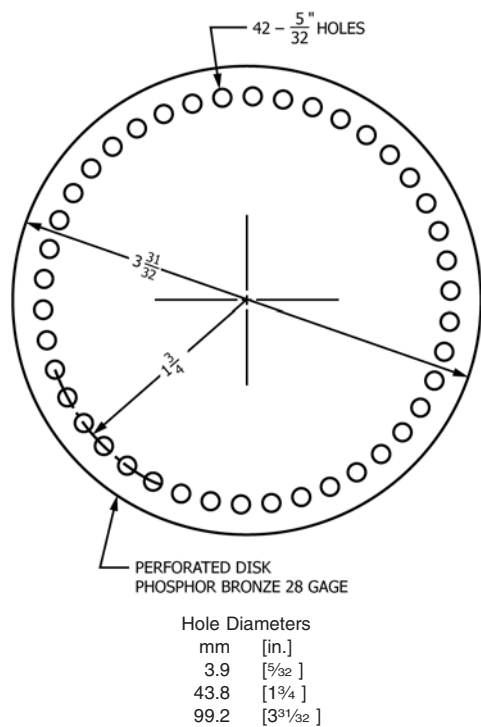

FIG. 6 Phosphor-Bronze Disk

8.3.1.3 The third notch will produce an upward 107 N [24 lbf] load. The dial indicator should register 0.160 mm [0.0063 in.].

8.3.1.4 The outermost notch will produce an upward 142 N [32 lbf] load. The dial indicator should register 0.213 mm [0.0084 in.].

8.4 The spring steel bar is considered in calibration when the measured deflections are within the tolerances listed in Table 2:

8.5 If the spring-steel bar is out of calibration adjust the expansion-pressure device as follows:

8.5.1 Loosen the nuts securing the top frame bar.

8.5.2 Adjust the position of the shims between the frame and spring-steel bar until the required readings are obtained.

8.5.3 Tighten the nuts securing the top frame bar taking care to not disturb the shim's positions.

8.5.4 Shim adjustment and zero adjustment of the deflection gauge may need to be repeated to obtain the four calibration readings within ± 0.005 mm [0.0002 in.].

NOTE 5—Moving the shims outward will comparatively increase the deflection movement for a given applied load. Conversely, moving the shims inward will decrease the deflection movement for a given applied load.

NOTE 6—Some models of the expansion-pressure apparatus have set screw adjustments in lieu of shims.

9. Expansion-Pressure Testing

9.1 Remove the phosphor-bronze disk, filter paper, and metal follower which were placed on the sample in 7.3. With the specimen still in the mold, place the mold on a flat non-absorptive surface. The surface of the specimen previously

covered by the phosphor-bronze disk and filter paper will be in contact with the flat non-absorptive surface.

9.2 Cover the top of the mold to minimize drying of the specimen. Allow the test specimen to rebound in the mold for at least 30 min after the determination of the exudation pressure.

9.3 Place the deflection dial indicator in position on the expansion-pressure device with the single-bearing end of the gage base resting on the adjustment ring.

9.4 Using an allen wrench, raise or lower the adjustment plug until the deflection dial indicator measures 0.025 mm [−1.0010 in.]. The deflection dial indicator will read 0.229 mm [0.0090 in.].

9.5 Place the 110 mm [4.3 in.] creped surface filter paper on the turntable. Remove the cover from the top of the mold. Place the perforated disk with stem, firmly on the face of the compacted specimen in the mold and place the mold in the expansion-pressure device.

9.6 Seat the perforated disk firmly on the specimen with pressure applied by the fingers. Raise the turntable on the expansion device until the deflection dial indicator reads zero. If the device was properly adjusted, according to 8.3, this will apply the preset surcharge deflection of 0.025 mm [0.0010 in.].

9.7 Rotate the specimen height measuring device toward the base of the turntable until it rests on the outer edge of the turntable.

9.8 Record the height of the specimen as indicated to the nearest 2.5 mm [0.1 in.].

9.9 Pour approximately 200 mL of potable water into the mold and allow the expansion pressure of the specimen to develop for 16 to 24 hours.

NOTE 7—Do not leave a test specimen unconfined by the expansion-pressure device while there is free water on top of the specimen in the mold.

9.10 Read the deflection of the calibrated spring steel bar to 0.002 mm [0.0001 in.]. When the deflection is greater than 0.254 mm [0.010 in.], the expansion-pressure device should be recalibrated before using again.

9.11 Determine the expansion pressure, P , as follows:

$$P = kd$$

where:

k = spring constant of steel bar calculated from the calibration of the expansion-pressure apparatus and expressed in kPa/0.025 mm [or psi/0.0010 in.], and,

d = deflection shown by deflection dial indicator, mm [in.].

NOTE 8—"k" needs to be determined experimentally using the apparatus. "k" can be theoretically calculated using the values given in Table 1. For example use the calibration value of the pressure dial (0.053 mm for 36 N [0.0021 in. for 8 lbf]) and the effective area of the disk. The calculated theoretical value of "k" is 0.207 kPa per 0.002 mm [0.030 psi per 0.0001 in.] deflection:

$$k = \frac{\text{Applied Load (lbf)}}{\text{Dial Reading (0.0001 in. deflection)} \times \text{Disk Area (in.)}^2}$$