



Designation: **D7486—14 D7486 – 22**

Standard Test Method for Measurement of Fines and Dust Particles on Plastic Pellets by Wet Analysis¹

This standard is issued under the fixed designation D7486; the number immediately following the designation indicates the year of original adoption or, in the case of revision, the year of last revision. A number in parentheses indicates the year of last reappraisal. A superscript epsilon (ϵ) indicates an editorial change since the last revision or reappraisal.

1. Scope*

1.1 This test method measures the amount of fine particles adhered on plastic pellets or granules in which they are commonly produced and supplied. The lower limit of this test method is restricted only by the porosity of the filter disc used to capture the particle size being quantified.

1.2 The wet analysis technique allows for separation and collection of statically charged particles by liquid wash and filtration methods. This must be performed under standard laboratory conditions.

1.3 The values stated in SI units are to be regarded as standard.

1.4 This test method describes an essential practice to check the quality of plastics once the production cycle is terminated and to evaluate the performance of pellet cleaning systems or of the special pneumatic conveying systems for the distinct size fractions below 500 micron only.

1.5 *This standard does not purport to address all of the safety concerns, if any, associated with its use. It is the responsibility of the user of this standard to establish appropriate safety, health, and environmental practices and determine the applicability of regulatory limitations prior to use.*

NOTE 1—There is no known ISO equivalent to this standard.

1.6 *This international standard was developed in accordance with internationally recognized principles on standardization established in the Decision on Principles for the Development of International Standards, Guides and Recommendations issued by the World Trade Organization Technical Barriers to Trade (TBT) Committee.*

2. Referenced Documents

2.1 ASTM Standards:²

[D883 Terminology Relating to Plastics](#)

[D1921 Test Methods for Particle Size \(Sieve Analysis\) of Plastic Materials](#)

[E11 Specification for Woven Wire Test Sieve Cloth and Test Sieves](#)

[E691 Practice for Conducting an Interlaboratory Study to Determine the Precision of a Test Method](#)

¹ This test method is under the jurisdiction of ASTM Committee [D20](#) on Plastics and is the direct responsibility of Subcommittee [D20.70](#) on Analytical Methods. Current edition approved Aug. 1, 2014; Nov. 1, 2022. Published September 2014. Originally approved in 2008. Last previous edition approved in 2013 as D7486 - 08(2013)14. ¹ DOI:10.1520/D7486-14; DOI:10.1520/D7486-22.

² For referenced ASTM standards, visit the ASTM website, www.astm.org, or contact ASTM Customer Service at service@astm.org. For *Annual Book of ASTM Standards* volume information, refer to the standard's Document Summary page on the ASTM website.

*A Summary of Changes section appears at the end of this standard

TABLE 1 Comparison of Typical Particle Sizes Measured

| Type | Lower Limit | Upper Limit | Test Method |
|-------|------------------------------|--------------------|-------------|
| D1921 | 500 μm | 2000 μm | dry |
| D7486 | 1.6 μm^{A} | 500 μm | wet |

^AThe lower limit is set by the porosity of the filter disk.

2.2 FEM Standards:³

FEM 2482 Test Method to Determine Content of Fines and Streamers in Plastic Pellets.

3. Terminology

3.1 *Definitions*—For definitions of terms associated with plastic materials, see Terminology **D883**.

3.2 Definitions of Terms Specific to This Standard:

3.2.1 *fines*—fines (Dust) are small particles of plastic which have been torn away from the original pellet by contact with a rough surface and friction at high conveying velocities. They are defined as the particle fraction with a particle size up to 2000 μm .

3.2.2 *streamers*—strings of plastics of various lengths that are created when the resin travels through pneumatic conveying lines at high velocity. Streamers are also known as angel hair, foil, floss, film or snake skin.

4. Summary of Test Method

4.1 Fines or streamers, or both, are generated in polymer resins during pneumatic conveying. Fines and streamers are known to cause problems in plastic producing and processing plants by clogging the transporting and procession lines. On finished products, fines cause the formation of gel, contamination, surface imperfection and weak spots.

4.2 The streamer content for a particle size considerably larger than the pellet diameter are determined by dry screening according to Test Method **D1921**.

4.3 The fundamental principle used in this document is based upon the condition that statically charged fines normally adhering to plastic pellets be removed by rinsing the test sample with a washing liquid, causing fines in the sample to wash away into a container. These particles are then poured into a filter funnel to separate the fines from the washing liquid. The weight of the filter paper is accurately measured before and after the collection process, and used to calculate the PPM level for that sample.

4.4 Wet analysis quantifies the amounts of dust with particle sizes typically from 1.6 to 500 microns.

5. Significance and Use

5.1 Molding and extruding plastic pellets require dust free, dry pellets to prevent processing problems. Plastic producers try to remove the dust and streamers with dust removal systems prior to packaging and loading. How to accurately measure dust and streamer content in plastic pellets is an important quality control issue.

5.2 Particle size analysis is used to determine a percentage of particle size distribution from a representative sample of the whole. In terms of size analysis concerning plastic pellets, sieving is used to determine the dust content in the range of 500 to 2000 micron. Test Method **D1921**, Test Method B, is used to determine this type of particle sizing.

5.3 After dry sieve analysis, particles smaller than 500 microns need to be analyzed by wet method. A fresh sample shall be used for wet analysis. This test method allows washing down the fines attached to the pellets by electrostatic forces.

5.4 The wet analysis provides accurate quantification of small to large amounts of fines, negating static effects, and eliminating detrimental effects of mechanical agitation. A wet analysis must be employed to accurately quantify lower PPM dust levels in plastic pellets.

³ Available from European Federation of Materials Handling, Diamant Building, 80 Boulevard Auguste Reyers B, 1030 Brussels, Belgium, <http://www.fem-eur.com>.

6. Interferences

- 6.1 Filtration paper has to be made of glass microfiber material. Paper filter fibers swell, reducing filtration speed and increasing filtration time.
- 6.2 Glass microfiber filters are fragile. Care must be taken when handling the wet filter to keep tears from being produced.
- 6.3 Some plastics contain certain additives that dissolve in washing liquids. This creates a particulate cloud of the washing liquid, clogs the filter paper, and gives inaccurate weight results.
- 6.4 When analyzing material that reacts with heat (low melting temperature), a lower drying temperature is required.
- 6.5 Too much material on a sieve causes mass blinding. Pellet bed depth has to be kept to no more than two pellets deep.
- 6.6 Replace the water and clean supply hoses on a regular basis. Algae or slime can develop and skew test results.
- 6.7 Discard sieves if the wire-cloth is damaged or no longer taut, as they no longer conform to Specification **E11**.
- 6.8 Use a non-stick, high temperature surface for the oven racks. The glass microfiber filter discs stick to the metal oven rack during the drying process.

7. Apparatus

- 7.1 The function of the apparatus (see **Fig. 1**) is to separate all fines below 500 micron from the pellets of the product sample to be tested. The apparatus runs with a washing liquid in recirculation mode.
- 7.2 The apparatus consists of a wash beaker with spray hose and nozzle, a filter funnel, a water tank reservoir with drain, a pump with throttle valve and flow meter, and connecting piping. The entire set-up consists of the following equipment.
- 7.2.1 *Balance*, with a capacity of 500 g or higher, sensitive to 0.1 mg.
- 7.2.2 *Scale*, with a capacity of 1200 g or higher, sensitive to 0.1 g.
- 7.2.3 *Oven*, gravity convection, controlled up to $100 \pm 5^\circ\text{C}$.
- 7.2.4 *Wire-Cloth Sieve*, 8-in. or 200-mm, full height, conforming to the requirements of Specification **E11**, 500 micron.
- 7.2.5 *Filtration Disc*, glass microfiber, diameter 90 mm, porosity 0.7 to 2.7 micron, thickness , 260 to 420 micron, tensile range, 5.5 to 8.9 N/15 mm.
- 7.2.6 *Filter Funnel Assembly*, 3-piece, borosilicate glass, able to hold a 90-mm filter disc.
- 7.2.7 *Filtering Flask*, 1000-mL, borosilicate glass, to connect to filter funnel.
- 7.2.8 *Beaker*, 1500-mL, borosilicate glass, to hold washed test sample.
- 7.2.9 *Funnel*, 260-mm. top O.D., to hold sieve during test sample washing.
- 7.2.10 *Nozzle*, flat fan spray, for washing test sample at line pressures below 2.8 Bar.
- 7.2.11 *Tweezers or Forceps*, blunt nose, for handling filtration disc.
- 7.2.12 *Plastic Sheet*, non-stick surface, polytetrafluoroethylene (PTFE), 1-mm thick, to keep filtration discs from sticking to oven rack during drying process.

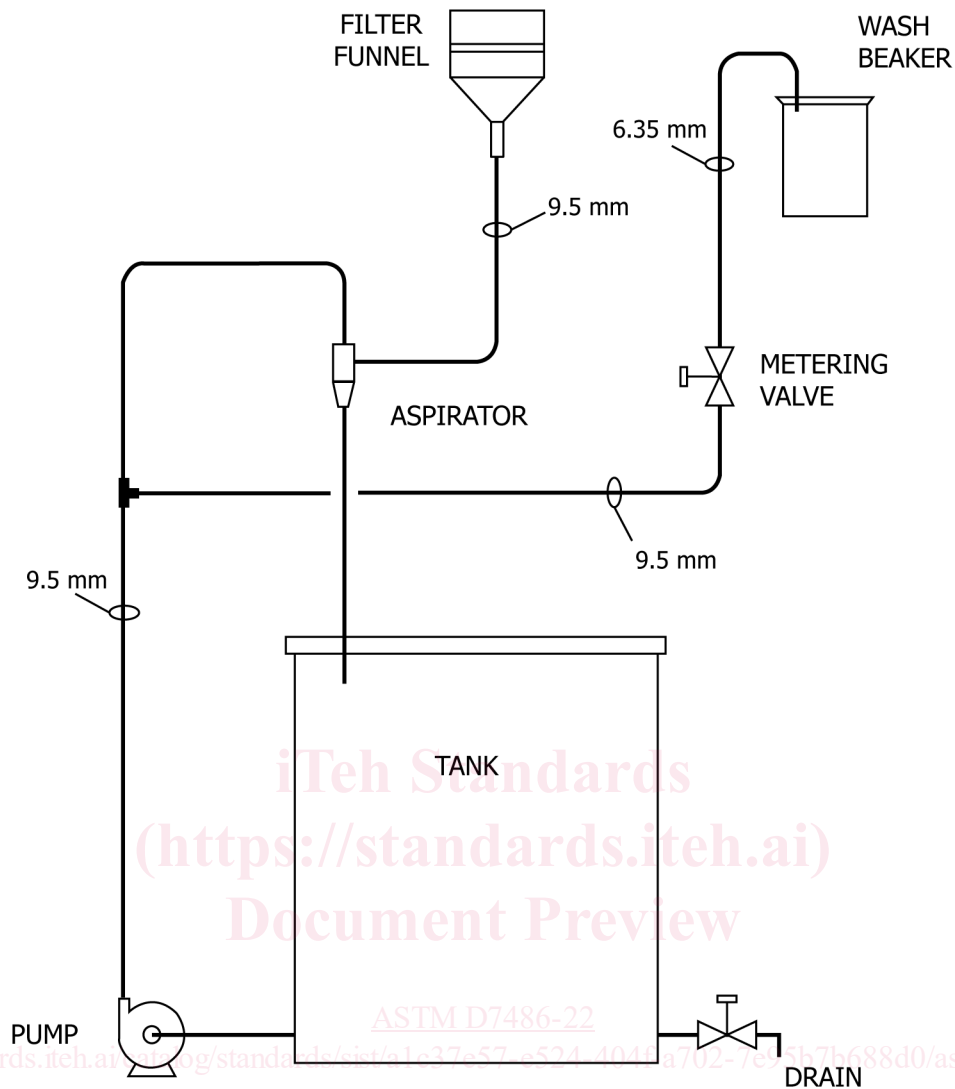

FIG. 1 Test Equipment for Determining Fines Content in Plastic Pellets

7.2.13 *Aspirator*, to allow flushing of sample and support return flow of water back to the storage tank.

7.2.14 *Water Storage Tank*, with drain valve and bottom outlet for recirculation loop. All inlet and outlet openings must be of sufficient size to enable the necessary liquid flow rates to be achieved.

7.2.15 *Wash Bottle*, with safety label, to rinse 1500-mL beaker and filter funnel assembly.

8. Test Specimen

8.1 Three test specimens of 100 g each have to be taken from a sample size of approximately 50 litres.

NOTE 2—The preferred sample size is 100 g but can be up to 200 g if the fines are low.

8.2 For samples taken during any part of the conveyance process, a larger sample size (test unit) can be obtained in order to collect the test specimen. When ready to perform the test, use a small scoop or cup to retrieve the test specimen from the approximate center of the test unit. With the beaker, funnel and sieve on the scale, pour the desired amount of material into the sieve. Any contaminate that remains inside the cup, or on the inner surfaces of the scoop, has to be brushed into the sieve pan, because it belongs to the test specimen.