



Designation: C878/C878M – 22

Standard Test Method for Restrained Expansion of Shrinkage-Compensating Concrete¹

This standard is issued under the fixed designation C878/C878M; the number immediately following the designation indicates the year of original adoption or, in the case of revision, the year of last revision. A number in parentheses indicates the year of last reapproval. A superscript epsilon (ϵ) indicates an editorial change since the last revision or reapproval.

1. Scope*

1.1 This test method covers the determination of the expansion of concrete made with shrinkage-compensating cement.

1.2 The values stated in either SI units or inch-pound units are to be regarded separately as standard. The values stated in each system may not be exact equivalents; therefore, each system shall be used independently of the other. Combining values from the two systems may result in non-conformance with the standard.

1.3 *This standard does not purport to address all of the safety concerns, if any, associated with its use. It is the responsibility of the user of this standard to establish appropriate safety, health, and environmental practices and determine the applicability of regulatory limitations prior to use.*

1.4 *This international standard was developed in accordance with internationally recognized principles on standardization established in the Decision on Principles for the Development of International Standards, Guides and Recommendations issued by the World Trade Organization Technical Barriers to Trade (TBT) Committee.*

2. Referenced Documents

2.1 *ASTM Standards:*²

[C125 Terminology Relating to Concrete and Concrete Aggregates](#)

[C192/C192M Practice for Making and Curing Concrete Test Specimens in the Laboratory](#)

[C219 Terminology Relating to Hydraulic and Other Inorganic Cements](#)

[C490/C490M Practice for Use of Apparatus for the Determination of Length Change of Hardened Cement Paste, Mortar, and Concrete](#)

¹ This method is under the jurisdiction of ASTM Committee C09 on Concrete and Concrete Aggregates and is the direct responsibility of Subcommittee C09.68 on Volume Change.

Current edition approved Oct. 15, 2022. Published December 2022. Originally approved in 1978. Last previous edition approved in 2014 as C878/C878M – 14a. DOI: 10.1520/C0878_C0878M-22.

² For referenced ASTM standards, visit the ASTM website, www.astm.org, or contact ASTM Customer Service at service@astm.org. For *Annual Book of ASTM Standards* volume information, refer to the standard's Document Summary page on the ASTM website.

[C670 Practice for Preparing Precision and Bias Statements for Test Methods for Construction Materials](#)

[C806 Test Method for Restrained Expansion of Expansive Cement Mortar](#)

[C845/C845M Specification for Expansive Hydraulic Cement](#)

2.2 *ACI Standards and Committee Reports:*³

[CT ACI Concrete Terminology](#)

[223R Guide for the Use of Shrinkage-Compensating Concrete](#)

3. Terminology

3.1 Terms used in this test method are defined in Terminologies [C219](#) and [C125](#).

NOTE 1—Additional terms not found in Terminologies [C219](#) or [C125](#) may be found in ACI CT.

4. Significance and Use

4.1 Since the potential for expansion, under conditions of controlled restraint, of concrete made with shrinkage-compensating cement cannot always be satisfactorily predicted from tests of mortars made in accordance with Test Method [C806](#), a need has been recognized for a test method in which concrete specimens are tested.

4.2 This test method can also be adapted readily to studies of expansion involving degrees of restraint, comparisons of cements, effects of cement contents, mixture proportions, schedules, or environmental treatments that differ from the standard procedures prescribed by this test method.

5. Apparatus

5.1 *Molds*, for casting test specimens, when used in conjunction with the restraining cage described in [4.2](#), shall provide for forming prisms 76 mm [3 in.] square with a gage length of 250 mm [10 in.]. The molds shall otherwise conform to the requirements for molds in Practice [C490/C490M](#), except that the stud holder, gage studs, and spacer screws described in that practice will not be used.

³ Available from American Concrete Institute (ACI), P.O. Box 9094, Farmington Hills, MI 48333-9094, <http://www.concrete.org>.

*A Summary of Changes section appears at the end of this standard

5.2 *Restraining Cage*, consisting of a threaded low-carbon steel rod (plain or zinc-coated) with steel end plates held in place by hex nuts as shown in Fig. 1. The hex nuts outside the cage shall be of stainless steel. Stainless steel cap nuts shall be put on each end of the rod. When tested in tension, within the elastic range, the rod shall have a strain of 2800 kN [0.0012 ± 0.0001/630 lbf] of load (Note 2).

NOTE 2—It is intended that all rods used meet the indicated requirement for strain. When a large number of rods are obtained as a single lot,

exercise judgment as to whether or not all must be tested. The designation “10-24” is used in ordinary rods having the desired properties.

5.3 *Length Comparator*, conforming to and to be used in accordance with the requirements of Practice C490/C490M. Use a reference bar complying with the description given in Practice C490/C490M. If the terminals of the comparator are fitted with collars, they shall be such that the cap nuts on the ends of the threaded rod of the specimen do not rest on the collar during the measuring (see Figs. 2 and 3).

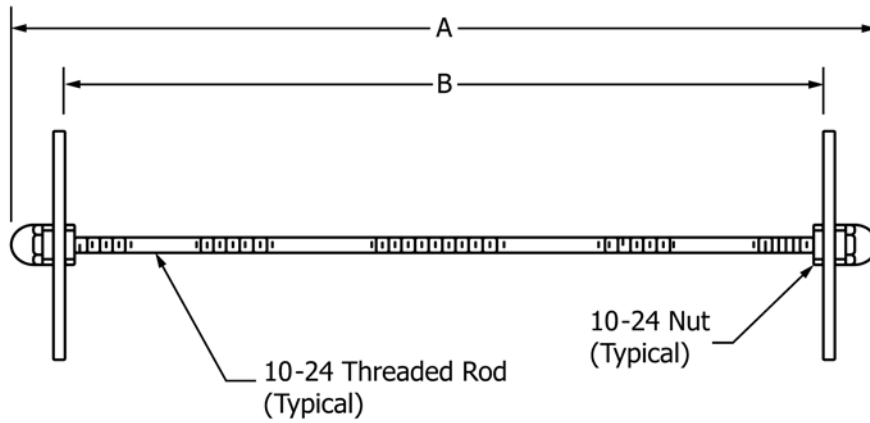

Assembled Restraining Cage

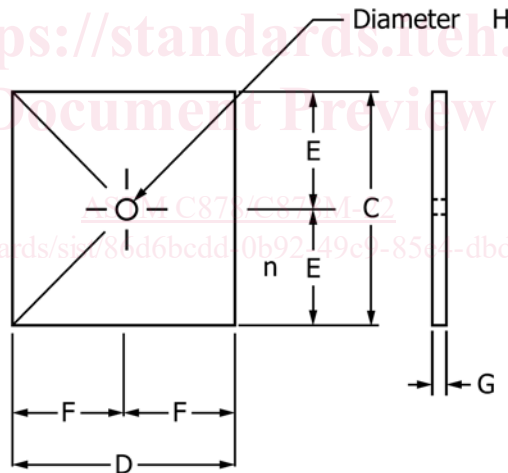

Measurement	Dimensions	
	in.	mm
A	11 ⁹ / ₁₆ ± 1/ ₁₆	294 ± 1.6
B	10	254 (gage length)
C	3	76
D	2 ³ / ₃₂ ± 1/ ₃₂	75 ± 1
E	1 ¹ / ₂	38
F	1 ³ / ₆₄	37.7
G	3/ ₈	10
H	3/ ₁₆	5

NOTE 1—All material is mild steel, except for stainless steel cap nuts.

FIG. 1 Restraining Cage

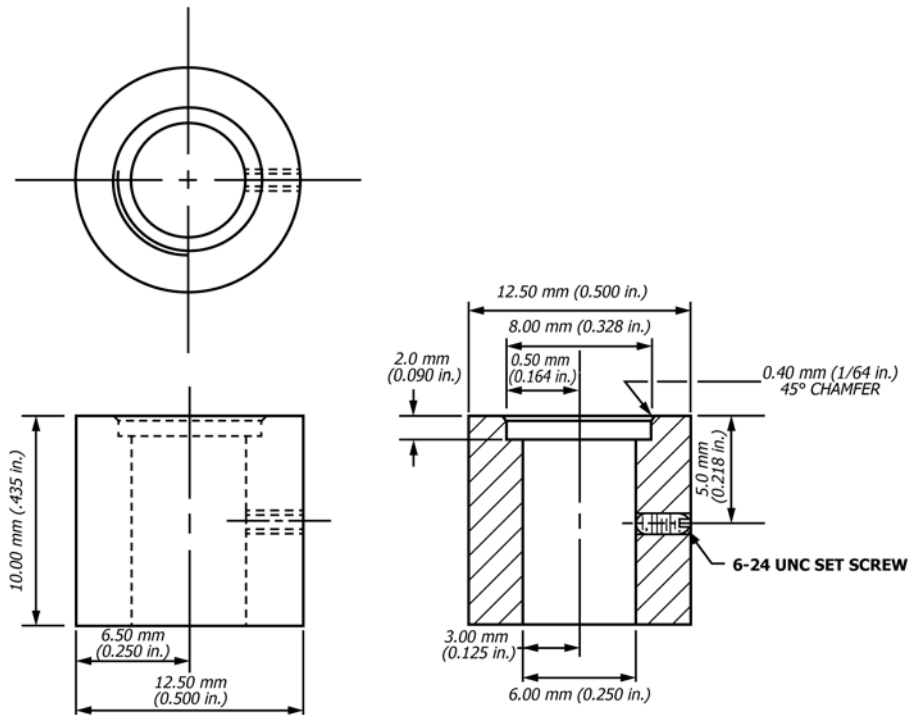

FIG. 2 Schematic of Upper and Lower Adjustable Restraining Collar for Length Comparator that Will Allow Positioning of Restraining Cage Cap Nuts to Rest on Anvils Without Interference from the Collars

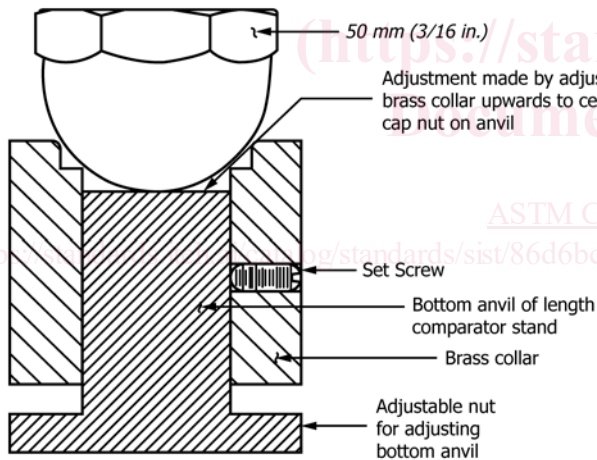

FIG. 3 Cross Section of Restraining Collar Showing Positioning of Cap Nut for Measurement

NOTE 3—Use of aggregates of nominal maximum size greater than 25.0 mm [1 in.] may adversely affect the test results.

7. Preparation and Assembly of Specimen Molds and Restraining Cage

7.1 Install the cap nuts firmly in place on the ends of the restraining rods using a suitable adhesive to keep them from loosening when comparator readings are made (Note 4). The cap nuts should not be removed after the initial comparator reading of a specimen is made. Measure the restraining cage assembly length, including the cap nuts, while it is at 23.0 °C ± 2 °C [73.5 °F ± 3.5 °F]. This is to ensure it is 30 mm ± 2 mm [1 1/16 in. ± 1/16 in.]. The measurement taken at this time is used only to ensure that comparator readings can be made.

NOTE 4—A rapid-setting epoxy has been found suitable.

7.2 Thinly cover the edges of the restraining cage end plates that contact the sides and bottom of the mold with a heavy mineral oil or light cup grease such as petrolatum. After assembly of the molds, place a restraining cage in each mold compartment. Seal the contact lines between the outer sides and base plate of the molds with paraffin or micro-crystalline wax. Thinly cover the interior faces of the molds with mineral oil and remove any oil or grease from the restraining cage rod and end plates.

8. Procedure

8.1 *Preparation and Mixing of Materials*—Mixtures using job materials shall be made in the laboratory as described in Practice C192/C192M, except that the material temperatures shall be approximately those anticipated in the field. Mixing procedures shall also reflect the actual mixing and delivery

5.4 *Tamping Rod*—The tamping rod shall be a straight steel rod, 10 mm [3/8 in.] in diameter, and no less than 250 mm [10 in.] in length, having at least the tamping end rounded to a hemispherical tip of the same diameter.

5.5 *Vibrators*, conforming to the requirements for external vibrators prescribed in Practice C192/C192M.

6. Test Specimen

6.1 The test specimen shall be a prism: 75 mm [3 in.] square with a gage length of 250 mm [10 in.] and an overall length (including the length of the rod and cap nuts) of approximately 290 mm [11.5 in.]. At least three specimens shall be prepared for each test.